

DRAWING NUMBER
308-14-14

SHEET No. 1 OF 1

A-A

10
✓ (✓)

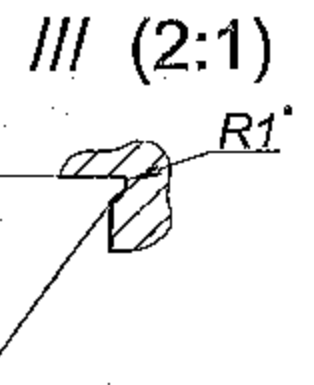
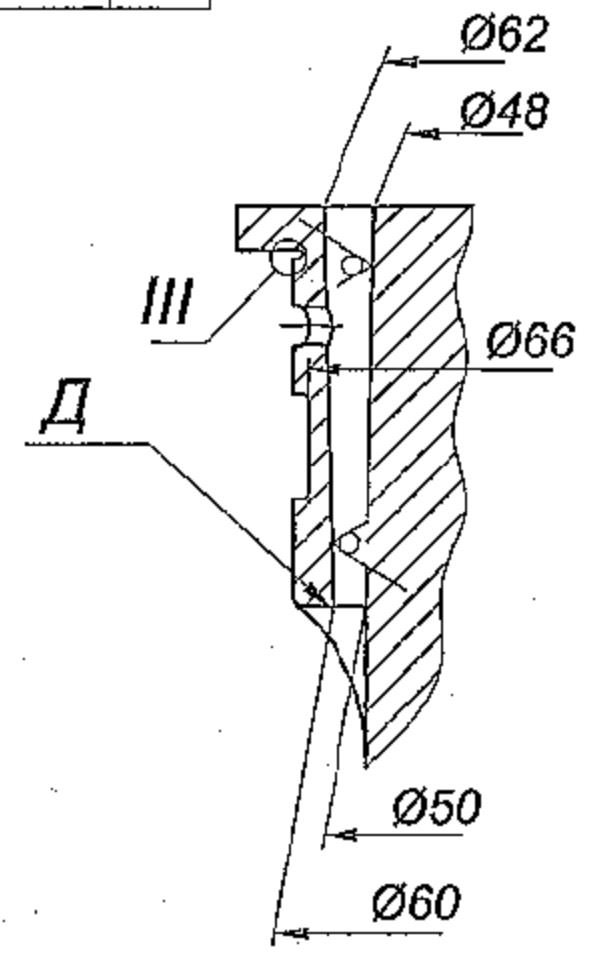
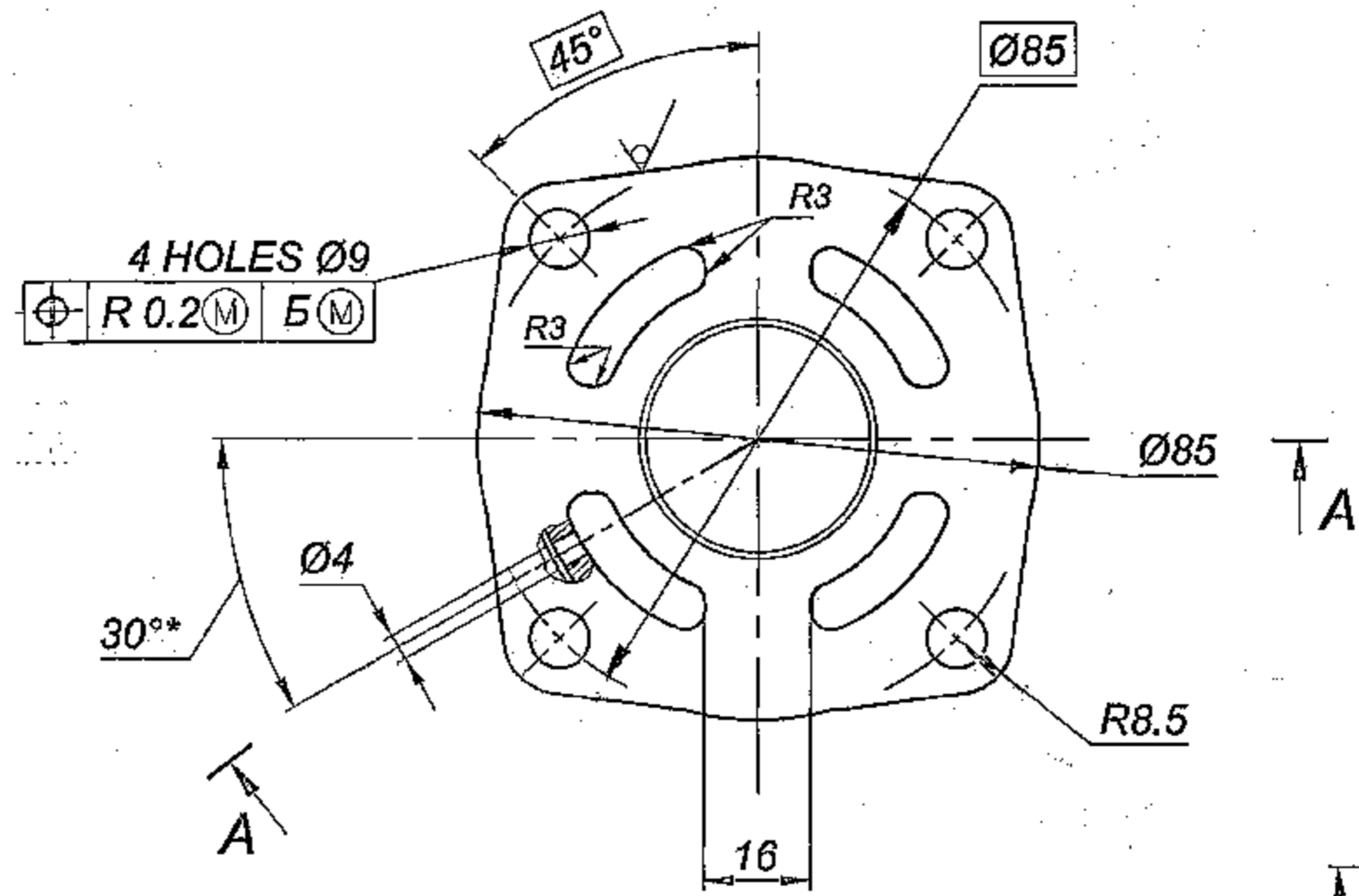
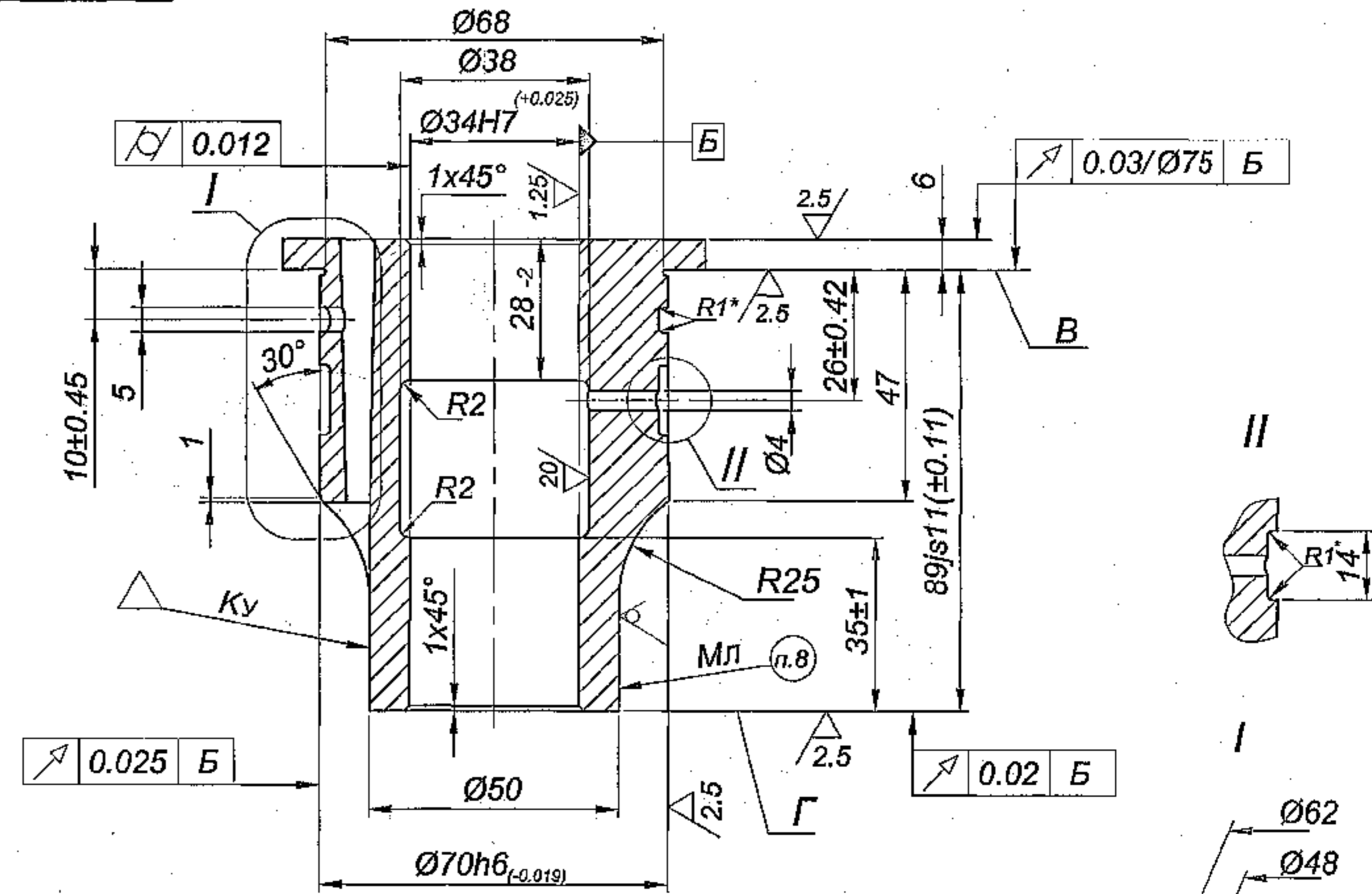

1. Requirement for casting as per TTM 65-78.
2. Hardness HB ≥ 80
3. Alternate material AK5M (АЛ5) GOST 1583-93.
4. Unspecified limit deviations of dimensions of casting should be:
 - Upto 50 mm $^{+1.5}_{-1.0}$ mm,
 - Above 50 mm $^{+2.0}_{-1.5}$ mm,
 - For radii of rounded off from 3 mm to 10 mm $^{+1.5}_{-1.0}$ mm.
5. Unspecified limit deviations of dimensions of machining should be H14, h14, $\pm \frac{IT14}{2}$
6. In the place Д, dressing the casting by R3 mm or chamfering 3x45° is permitted.
7. Check the deviation from flatness of surfaces B and Г "by bluing" prepared and applied as per instruction ИЛ - 613-85. The imprint should be uniform and should cover 50% minimum of the surface.
8. It is permitted to stamp the grade of material by punching as per GOST 2171-79 with letter type 10-Пп3 GOST 26.008-86
9. * Dimensions to be ensured by tool.

PILOT SAMPLE SHOULD BE APPROVED BY А И С П BEFORE BULK PRODUCTION.

EST. WT. (Kg) 0.471 TO BE STAMPED OR MARKED WHERE INDICATED THUS # (LETTERS)

ALL SHARP EDGES AND CORNERS TO BE REMOVED UNLESS OTHERWISE STATED MACHINED CORNERS TO HAVE R OUTSIDE R INSIDE EQUIVALENT CHAMFERS ARE PERMISSIBLE.

DRN	APPD	MATERIAL:- AK74(АЛ9) GOST 1583-93	USED ON:- CB 3308-00-23
DATE	SCALE:- 1:1	CONTROLLERATE OF QUALITY ASSURANCE (HEAVY VEHICLES) AVADI	
DIMENSIONS IN mm		TITLE:- BEARING	
TOLERANCE ON DIMNS UNLESS OTHERWISE STATED IS: 2102-69		D S CAT NUMBER	
ALL THREADS TO CONFORM TO		DRAWING NUMBER 308-14-14	
ISSUE	DATE	NATURE OF AMENDMENTS	

DRG. INDIANISED BASED ON RUSSIAN ORIGINAL ISSUE - NIL

F-3
728
766
SIZE A2