

1005-008025

DRAWING CONVENTIONS CONFORM TO JSG:0104
 DIMNS ARE IN mm. GEN. TOL. 'MEDIUM' IS:2102

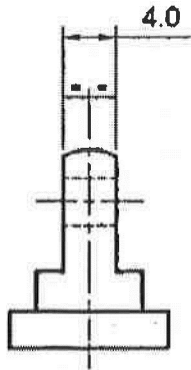
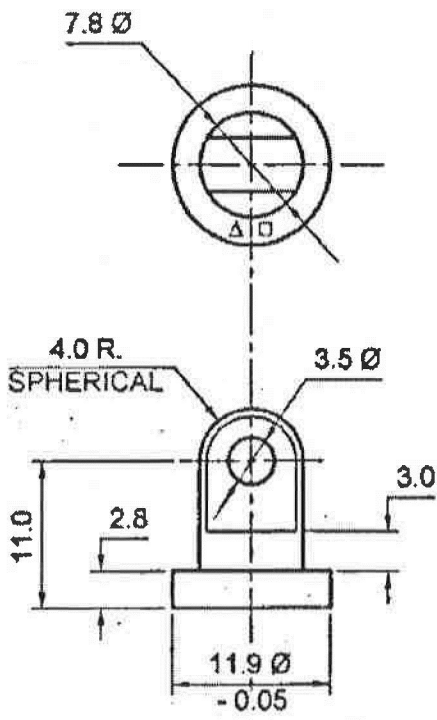

NOTES:-
 REMOVE ALL SHARP EDGES AND BURRS.

MARKING NOTE:-
 TO BE MARKED ON COMPONENT BY STAMPING IN 2mm. LETTER SIZE:-

Δ MANUFACTURER'S CODE.
 □ Yr. OF Mfg.

DC No. 26949-SA, DT. 27-09-2016					
24-09-08	26433-SA	DRG. PROV. SEALED			
DATE		AUTHY.		BRIEF RECORD	
SEALD :- DC No. 26433-SA Dt. 24-09-08.				SIGN.	
DRN. 26433-SA	CHD. A.B.	TRD.	COMP.	AHSP. CQA(SA) ICHAPUR	
SCALE :- 2:1		EST. MASS			
DT. 24-09-08		APPROVED		ASSY. 1005-557898	
MATERIAL :- IS: 5517-1993 DESIGNATION 40C8.		I/C: DO. DT. 24-09-08.		FOR CQA(SA)	
H.T./HARDNESS :- 300 - 350 H.V.		DGNR'S. ARDE SK 3145		REF. DET NO. 69	
PROTECTIVE :- PHOSPHATE TO SPECN. JSS : 0465 - 01 : FINISH 1994 CLASS II (ACCELERATED), OIL FINISH.		PART No.			
NOMENCLATURE :- LUG, SLING		DRG. No.			
		D.S.CAT. No.		1005-008025	

2200415
V-04
P-21

DC No. 26948-SA, DT. 26-09-2016

SECTION- B-2

GUN MACHINE 5.56mm. 1A1

INSERT 'A'

D.S. CAT. No. 4933-000434

MATERIAL AMENDED:-

FOR : STEEL BS: 970 En-8.

READ: IS: 5517-1993 DEGIGNATION 40C8.

INSERT 'B'

D.S. CAT. No. 4933-000435

MATERIAL AMENDED:-

FOR : STEEL BS: 970 En-8.

READ: IS: 5517-1993-DEGIGNATION 40C8.

HOUSING PLUNGER

D.S. CAT. No. 1005-007900

MATERIAL AMENDED:-

FOR : STEEL BS: 970 PT-1:1983, Gr.070 M 55 (En 9).

READ: IS: 5517-1993 DEGIGNATION 55C8.

COLLAR BARRE

D.S. CAT. No. 1005-007963

MATERIAL AMENDED:-

FOR : STEEL BS: 970 PT-1:1983, 070 M 55.

READ: IS: 5517-1993 DEGIGNATION 55C8.

PLUNGER, CARRYING HANDLE

D.S. CAT. No. 1005-557933

MATERIAL AMENDED:-

FOR : STEEL BS: 970 PT-1:1983, Gr.070 M 55 (En 9).

READ: IS: 5517-1993 DEGIGNATION 55C8.

MATERIAL AMENDED.

2200415
V-04
P-21

DC No. 26949-SA, DT. 27-09-2016

SECTION- B-2

GUN MACHINE 5.56mm. 1A1

HOUSING

D.S. CAT. No. 1005-007955

MATERIAL AMENDED:-

FOR : STEEL BS: 970 PT-1:1983, Gr.080 M 40.

READ: IS: 5517-1993 DEGIGNATION 40C8.

HOUSING LUG SLING

D.S. CAT. No. 1005-008021

MATERIAL AMENDED:-

FOR : STEEL BS: 970 PT-1:1983, Gr.080 M 40 (En 8).

READ: IS: 5517-1993 DEGIGNATION 40C8.

LUG, SLING

D.S. CAT. No. 1005-008025

MATERIAL AMENDED:-

FOR : STEEL BS: 970 PT-1:1983, Gr.080 M 40(En 8).

READ: IS: 5517-1993 DEGIGNATION 40C8.