

DRG. CONVENTIONS CONFORM TO IS: SPECIFICATIONS.  
DIM ARE IN mm. UNLESS OTHERWISE STATED.

DC 36552-A

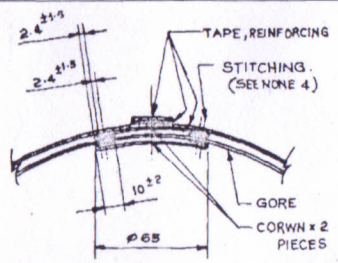

SECTION A-A

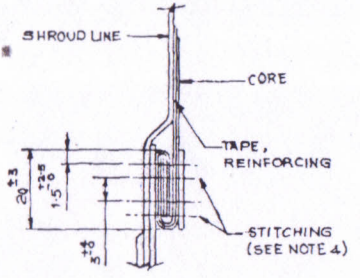
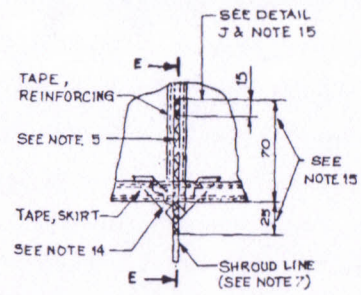
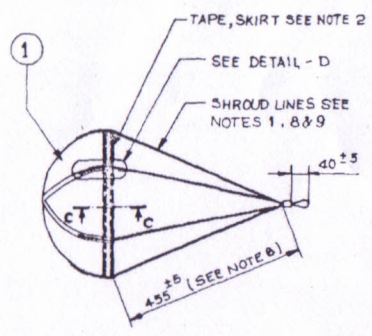
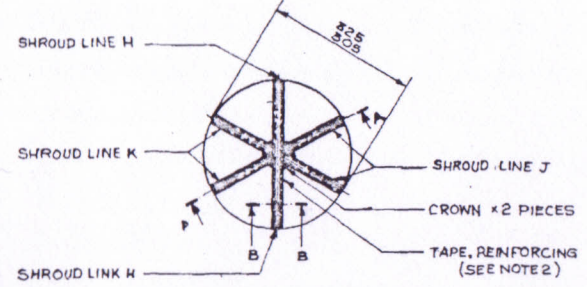
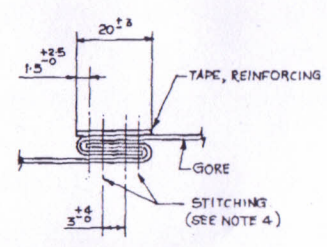

SECTION B-B

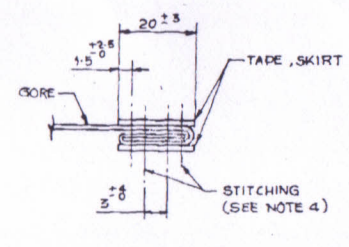

SECTION C-C

NOTE :-

- MATERIAL : CORD, NYLON, TYPE IV, TO SPEC. MIL-C-7515E  
INDIGENOUS EQUIVALENT - CORD, NYLON 6mm (BS 500 Kg) TO SPEC. IND/Eng/Prov/0778.
- MATERIAL : TAPE, NYLON, 20mm WIDE, TYPE III, TO SPEC. MIL-T-5038F.  
INDIGENOUS EQUIVALENT - TAPE, NYLON (19mm) OG (BS 193 Kg) TO SPEC. IS : 4228-79
- MATERIAL : TAPE 25mm WIDE, SINGLE HERRINGBONE, NYLON TO SPEC. BRAITEX 760-310  
INDIGENOUS EQUIVALENT - TAPE, NYLON 26 MED U/D (BS 600 Kg) TO SPEC. AD/DRDE/BP/1 (b).
- STITCH TYPE 301, 7-11 STITCHES PER 25mm TO SPEC. FED-STD-751A, ROWS AS SHOWN  
THREAD TYPE METRIC 40 NATURAL LUBEX QUALITY 720 TO SPEC. SABS 1362 : 1962  
INDIGENOUS EQUIVALENT - THREAD SEWING NYLON V No. H2 TO SPEC. IS 4229 : 1992. REAFFIRMED 2008.
- STITCH TYPE 308 4mm WIDE, 6-10 STITCHES PER 25mm TO SPEC. FED-STD-751A USING A17W15 MACHINE OR EQUIVALENT (NOTE 6)
- USE THREAD NYLON TYPE METRIC 10 NATURAL LUBEX QUALITY 720 TO SPEC. SABS 1362 : 1982.  
INDIGENOUS EQUIVALENT - THREAD SEWING NYLON V No. L2 TO SPEC. IS : 4229 : 1992. REAFFIRMED 2013
- NYLON CORD SHALL BE SEARED TO PREVENT FRAYING.
- DIMENSION APPLIES WITH A LOAD OF 2.3 Kg APPLIED.
- SHROUD LINE LENGTH VARIATION IN ANY ONE ASSY SHALL BE NO GREATER THAN 6mm
- THE FLYING DIA. OF THE PARACHUTE SHALL BE BETWEEN 305 & 325mm.
- NYLON WEBBING, 20mm WIDE COLOUR NATURAL OR CONTRASTING COLOUR TO SPEC. MIL-W-5625  
INDIGENOUS EQUIVALENT - TAPE, NYLON TUBULAR 2.54 cm U/D (BS 17500 N) AD/DRDE/SPEC/1985/27
- TOLERANCE UNLESS OTHERWISE STATED : ± 3mm.
- FOR METHOD OF FOLDING PARACHUTE, DROGUE REFER DRG No. 2440A 20002
- V-TAB TO BE ATTACHED USING A 107 W1 MACHINE OR EQUIVALENT USING ZIGZAG 12-16 STICHES PER 25mm. V-TAB MATERIAL : BRAITEX 760/322/48, 15mm WIDE.  
THREAD TYPE METRIC 40 NATURAL QUALITY 720 TO SPEC. SABS 1362 : 1982  
INDIGENOUS EQUIVALENT - TAPE TEXTILE, NYLON 14mm U/D (BS 230 Kg) TO SPEC. JSS 8313-6.  
THREAD SEWING NYLON V No. H2 TO SPEC. IS 4229 : 1992. REAFFIRMED 2008
- BACK TACK STITCHING AS INDICATED (STITCHING ON UPPER END OF SHROUD LINE TO COMMENCE BELOW HEAT SEARED END OF SHROUD LINE.)

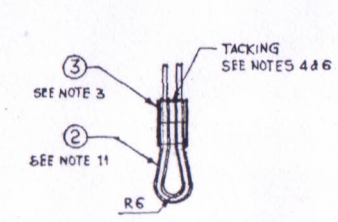

SECTION G-G

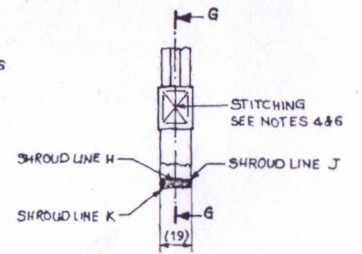

DETAIL-F

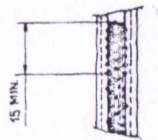

DETAIL - J

LIST OF COMPONENTS				
ITEM No	DESCRIPTION	DESIGNER REF	PART No	No. PER SET
1	GORE	2440A 20017		6
2	WEBBING TUBULAR (140± 5mm LONG)			1
3	TAPE (90± 5mm LONG)			1

01-02-2020	DC 37546-A	NEW MASTER COPY & NEGATIVE REPLACED IN SUPERSESSION OF EXISTING DILAPIDATED COPY. ADDED INDIGENOUS EQUIVALENT FOR NOTE No 1, 2, 3, 4, 6, 11 & 14.		
24-04-1999	DC 36552-A	DRG SEALED (PROV)		
R. NO.	DATE	AUTHORITY	REVISION	ZONE

DRG-	TRD-PCD	CHK-	CR-	TRNCHD-	SCALE- NOT TO SCALE
APPRD-	C.D/MAN	0 V/C D.O.	EST. MASS-	GAUGE SCHER-	DATE-
MATERIAL- SEE NOTE 1					
PROTECTIVE FINISH- N.A.					

ASSY DRG. 2440A20014
DESIGNER'S REF. 2440A 20015
PART NO.
D.S. CAT NO.
AHSP:- CQA(A) KIRKEE

DROGUE PARACHUTE



DRG. CONVENTIONS CONFORM TO IS: SPECIFICATIONS.  
 DIMENSIONS ARE IN mm. UNLESS OTHERWISE STATED.

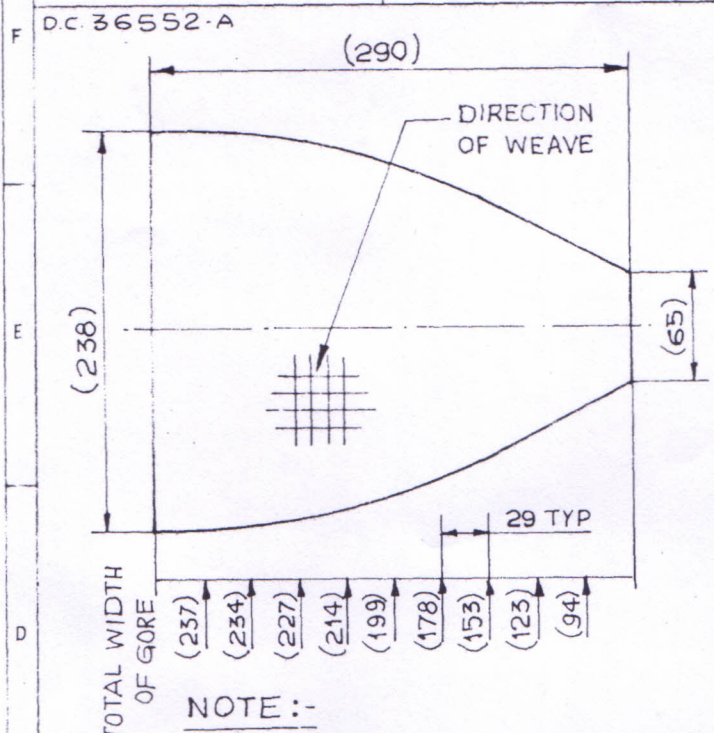

**NOTE :-**

- TOLERANCES APPLY TO TEMPLATE USED IN CUTTING MATERIAL.
- TOLERANCES UNLESS OTHERWISE STATED: LINEAR  $\pm 5$  mm.
- DIMENSIONS GIVEN ARE FOR GUIDANCE ONLY. SIZES STATED ON DROGUE PARACHUTE DRG. NO 2440A20015.
- MATERIAL :-**  
 CLOTH, PARACHUTE, TYPE I, CLASS B, TO SPEC. MIL-C-1720E B. PARA 3.6.1 OF SPECN. IS NOT APPLICABLE.  
 INDIGENOUS EQUIVALENT :- FABRIC NYLON 230g UD WIDTH 92cm TO SPEC. ADRDE/SPECN/1985/29

1/2/2020	DC. 37546-A	INDIGENOUS EQUIVALENT ADDED.			
24-4-99	D.C. 36552-A	DRG. SEALED (PROV.)			
R.No.	DATE	AUTHORITY	REVISION	ZONE	AHSP D.O. SIG

DRG. SEALED:- 24-4-99 (PROV.)

DRN:-	TRD:- RCD	CHD. <i>Ca</i>	TRNCHD:-	ASSY DRG. 2440A20015
<i>V.S. Samudra</i> C.D'MAN	<i>W.K.</i> O I/C D.O	SCALE:- NOT TO SCALE		
APPD	<i>W.K.</i> FOR CQA(A)	EST. MASS:-		
MATL:- AS ABOVE, SEE NOTE 4				DESIGNER'S REF
PROTECTIVE FINISH:- N. A.				2440A20017
<p style="text-align: center;"><u>GORE</u></p>				PART No.
				D.S.CAT NO
				AHSP:- CQA(A) KIRKEE