

WORKMANSHIP & FINISH:- TO BE FINISHED SMOOTH  
CADMIUM PLATED TO A  
MINIMUM THICKNESS OF 0.012mm  
AND CHROMATE PASSIVATED  
TO SPECN-IS:1572,1968-CD-12

PROOF LOAD:- 1470 N (150 Kg.)  
(NOTE:- SAMPLE TO BE PROOF LOADED AS SHOWN)

ASSEMBLY

PACKING CLAUSE:- EACH SAMPLE SHALL BE WRAPPED IN  
TISSUE PAPER AND 50 Nos. THUS WRAPPED BE PACKED  
IN A SUITEABLE CRATON 20 SUCH CARTON SHALL BE  
PACKED IN A C.W.P. (DULLY LINED WITH PAPER PACKING  
WATER -PROOF ) ONE SAMPLE IN EACH CARTON SHALL BE  
IDENTIFIED) BY A LABEL SHOWING NOMENCLATURE  
AND CAT NO. OF THE STORE AND ALSO THE TRADEMARK/  
INITIAL OF THE MANUFACTURER AND THE YEAR OF  
MANUFACTURE.

2	SEPARATED BAR	3 OF 3	1
1	RING	2 OF 3	1
—	ASSEMBLY,PACKING CLAUSE	1 OF 3	—
SL.No.	NOMENCLATURE	SHEET No.	No. OFF

DETAIL INDEX

BEFORE DESPATCH EACH PACKING CASE SHALL BE  
LEGIBLY AND INDELIBLY MARKED WITH THE FOLLOWING  
DETAIL:-  
(i) NOMENCLATURE CAT.No. OF THE STORE AND THE YEAR  
OF MANUFACTURE.  
(ii) TOTAL No.OF PACKING CASES AND THE NUMBER OF  
THE INDIVIDUAL PACKING CASE IN A CONSIGNMENT  
(iii) No.OF CARTONS IN EACH PACKING CASE AND THE  
QUANTITY IN EACH CARTON.  
(iv) OF THE PACKING CASE IN Kg.  
(v) ADDRESS OF THE CONSIGNE.  
(vi)ADDRESS OF THE CONSIGNOR.

SCALE:- NTS	A D R D E AGRA	DRN.	C.P.PAL	 PROJ. OFFR./GROUP OFFR.
DIMENSIONS IN mm	GROUP- PAS	CHD.	NIROTI	
TOL:- IS:2102 Pt. 1(MeD.) 1993	<b>ASSEMBLY CLASP SERATED FOR PACK COVER</b>			APPROVED  PROJ.OFFR./GROUP OFFR.
MATERIAL:- AS ABOVE				DRG. No.
FINISH:-				
HEAT TREATMENT:-				

1

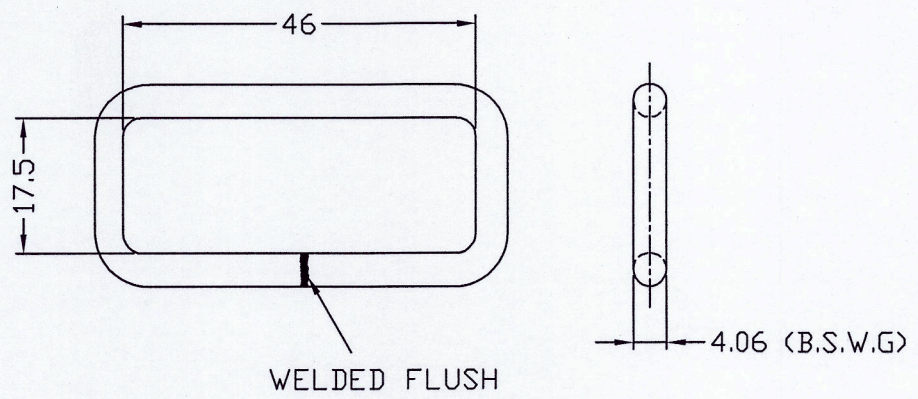

1-OFF

MATERIAL:- MILD STEEL WIRE TO IS:280-1962

Rev.No.				DATE				ZONE				AUTHORITY				BRIEF RECORD				I/C CAD		GROUP HEAD	
SCALE:- N.T.S				A D R D E AGRA				DRAWN BY				C.P.PAL				PROJ. OFFICER/GROUP OFFICER <i>[Signature]</i>							
DIMENSIONS IN mm				GROUP:- PAS				CHECKED				NIROTI											
TOL:- AS ABOVE				RING CLASP SERATED FOR PACK COVER D-10 MAIN PARACHUTE				APPROVED BY <i>[Signature]</i> PROJ. DIRECTOR/GROUP DIRECTOR				DRG. No. 2.1.01-28-01											
MATERIAL:-																							
FINISH:-																							
HEAT TREATMENT:-																							
				1		2		3		4													

2

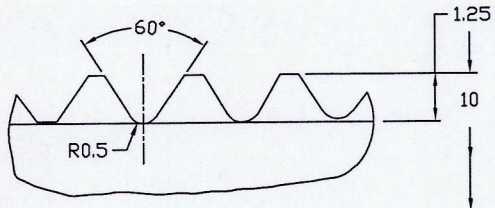

DETAIL OF SERRATIONS

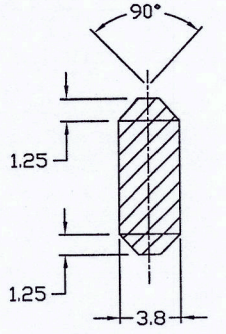
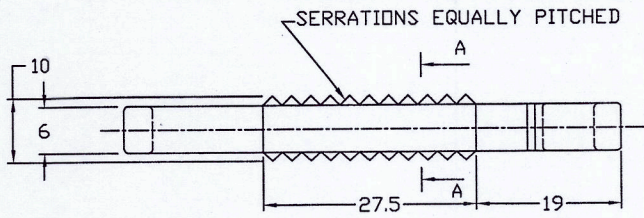

SECTION-AA

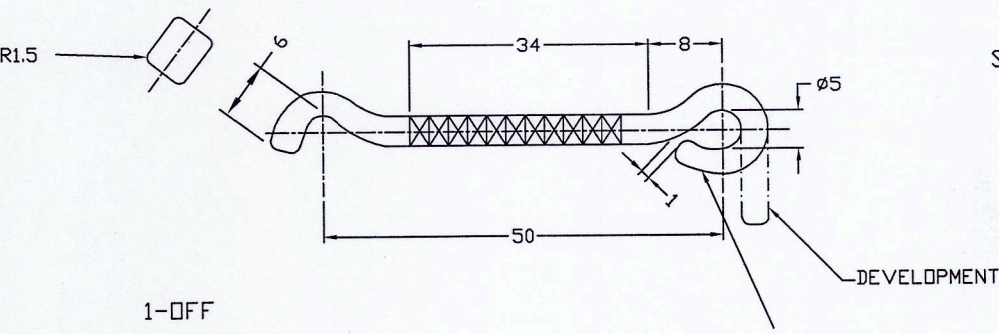

1-OFF

TO BE CLOSED AFTER ASSEMBLY.

MATERIAL:- MILD STEEL IS 280-1962

SCALE:- NTS	A D R D E AGRA	DRN.	C.P.APL	 PROJ. OFFR./GROUP OFFR.
DIMENSIONS IN mm	GROUP- PAS	CHD.	NIROTI	
TOL:- AS ABOVE	<b>SERRATED BAR CLASP SERATED FOR PACK COVER D-10 MAIN PARACHUTE</b>			APPROVED
MATERIAL:- AS ABOVE				 PROJ.OFFR./GROUP OFFR.
FINISH:-				DRG. No.
HEAT TREATMENT:-				2.1.01-28-02

Rev.No.	DATE	ZONE	AUTHORITY	BRIEF RECORD	I/C CAD	HEAD GROUP
1						