

1005 - 008024

DRAWING CONVENTIONS CONFORM TO JSG:0104  
 DIMNS ARE IN mm. GEN. TOL. 'COARSE' IS:2102

**NOTES :-**

REMOVE ALL SHARP EDGES AND BURRS.

**MARKING NOTE :-**

TO BE MARKED ON COMPONENT BY STAMPING  
 IN 2 mm. LETTER SIZE.

- Yr. OF Mfg.
- △ MANUFACTURER'S CODE

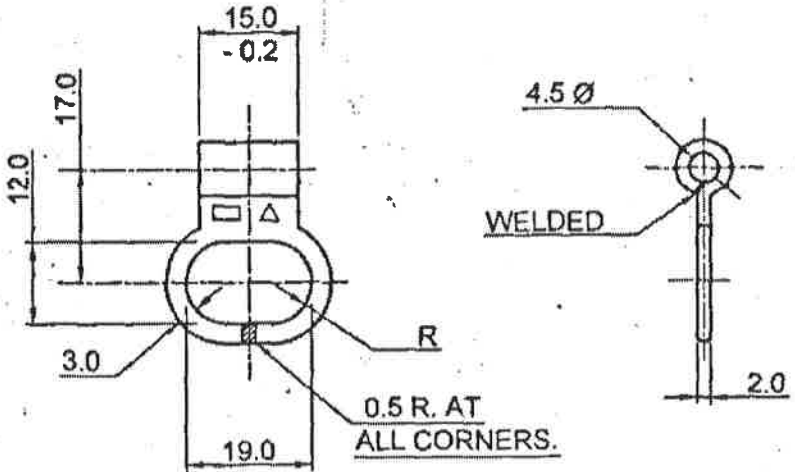

30-9-08	26435-5A	DRG SEALED PROV					
		PREVIOUS D.C.No. 25918 - SA					
DATE	AUTHY.	BRIEF RECORD			ZONE	I/C:DO.	G.O.
SEALED :- PROV SEALED DC NO 26435-5A Dt. 30-09-08.							SIGN
DRN.	D.D.	CHD.	TRD.	COMP.	AHSP. CQA(SA) ICHAPUR		
SCALE :- 1:1.		EST. MASS					
Dt. 30-9-08.		APPROVED		J.T.O.		ASSY. 1005 - 557868	
		I/C. DO.		Dt. 30-9-08.		FOR CQA(SA)	
MATERIAL :- STEEL BS 1449 : Pt 1 : 1983 - Cr 4 / Cs 4.							
H.T./HARDNESS :-					DGNR'S. ARDE SK. 3145		
PROTECTIVE PHOSPHATE TO SPECN. JSS : 0465 - 01 : 1994					REF. DET.No. 74		
FINISH :- CLASS II (ACCELERATED), OIL FINISH.					PART No.		
					DRG. No.		
NOMENCLATURE :- LOOP SLING FRONT					D.S.CAT. No. 1005 - 008024		