

1 2 3 4 5 6 7 8

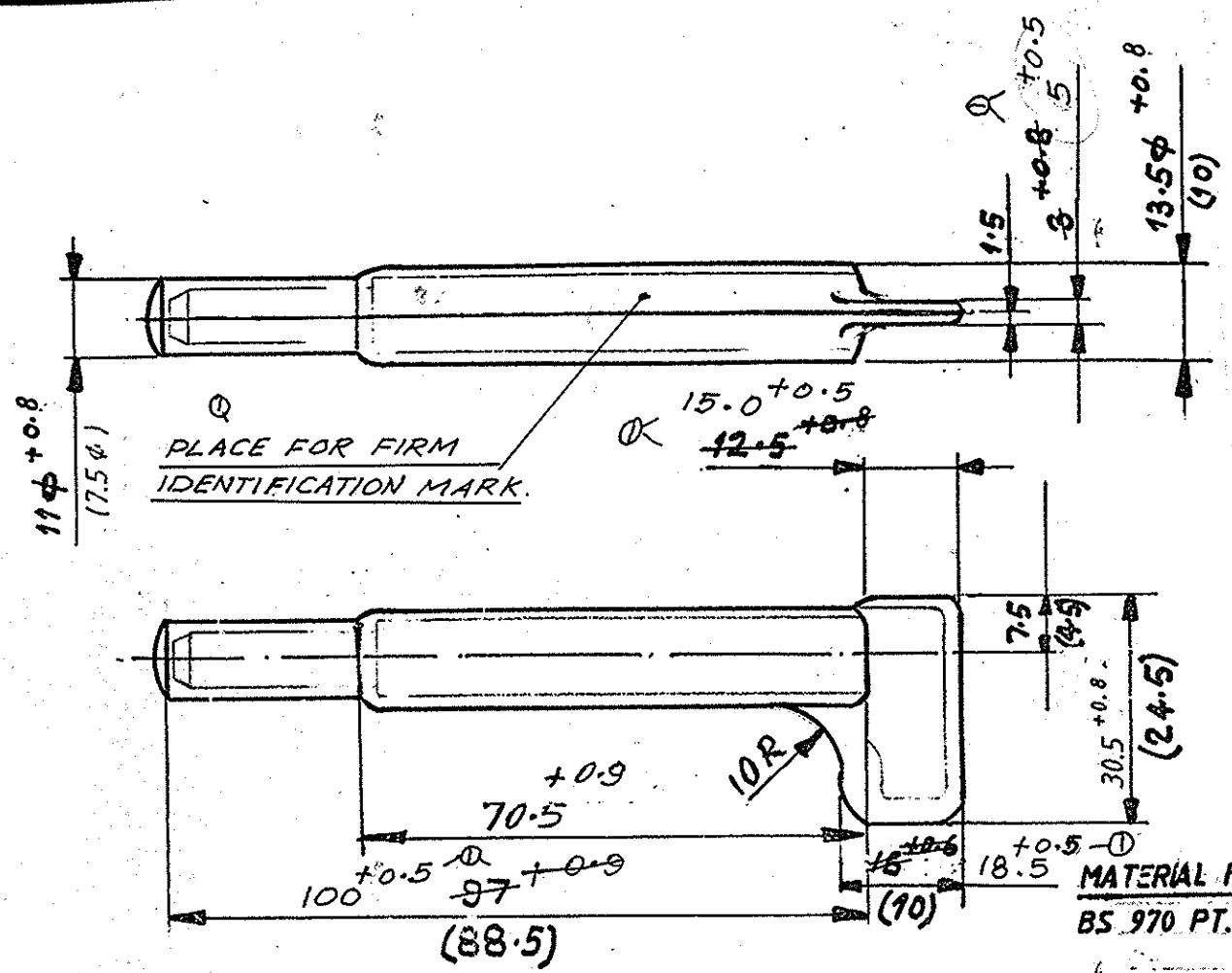

Q
PLACE FOR FIRM
IDENTIFICATION MARK.

MATERIAL FOR INDIA

- BS 970 PT. 1 : 1983 GR. 530 M-40 (BS 970 : 1955 EN-18)
- OR
- BS 970 PT. 1 : 1983 GR. 709 M-40 (BS 970: 1955 EN-19)
- OR
- BS 970 PT. 1 : 1983 GR. 708 M-40 (BS 970/ 1955 EN-19 A)

NOTES :-

1. DIMENSIONS ARE IN mm.
2. FIRST ANGLE PROJECTION.
3. SCALE:- 1:1
4. FORGING OF GROUP II AS PER GOST 8479-70. HB 217 MAX.
5. DRAFT ANGLE 7°.
6. UN-SPECIFIED RADII 2 R.
7. FLASH REMAINDER UP TO 0.9 mm.
8. WARPING UP TO 0.7 mm.
9. DIE SHIFTING UP TO 0.3 mm.
10. CONVENTIONAL CONTOUR AND DIMENSIONS GIVEN IN BRACKETS PERTAIN TO THE FINISHED PART.
11. STAMP PART NO, MELT NO. AND Q.C.D STAMP ON THE TAG.
12. 5% OF A BATCH SHOULD BE CHECKED FOR HARDNESS AS PER GOST 8479-70.
13. WEIGHT OF THE FORGING 0.110 Kgs.

HEAT-TREATMENT:-FORGINGS ARE NORMALIZED AND TEMPERED.
FOR HEAT-TREATMENT SCHEDULE REFER DRAWING
NO: M 881 SHEET NO: 1 TO 3 AND SHEET NO: 6 SL.NO: 22.

MATERIAL :- STEEL 40X OST 3-98-80, ✓
ALT.MATERIAL : STEEL 40 X GOST 4543-71 ✓

COMPONENT DRG. NO. 6P11-7-7
CHANGE LEVER

VETTED FOR MATERIAL ONLY

[Signature]
Principal Scientific Officer,
Quality Assurance Officer,
For Senior Quality Assurance Officer,
Senior Quality Assurance Estt. (Army)
Tiruchirapalli - 620 016.

DA.NO. 65/03 Dt. 04/08/03

DRAWING PROVISIONAL

DS.CAT NO. 1005007171

B	ALTERNATE MATL. EN SERIES ADDED	SIG & DATE
AMENDMENTS	DESCRIPTION/DETAILS	

<i>Sadhi</i> 27/10/82	<i>[Signature]</i> 11.8.82	<i>[Signature]</i> 11.8.82	<i>[Signature]</i> 11.8.82
REDRAWN	CHECKED	APPROVED	I/C. D & DO DIV. OFFICER

ORDNANCE FACTORY,
TIRUCHIRAPALLI-16.

DRG. NO.:
62 C 7007 200 C 3