

DIMENSIONS ARE IN MM.

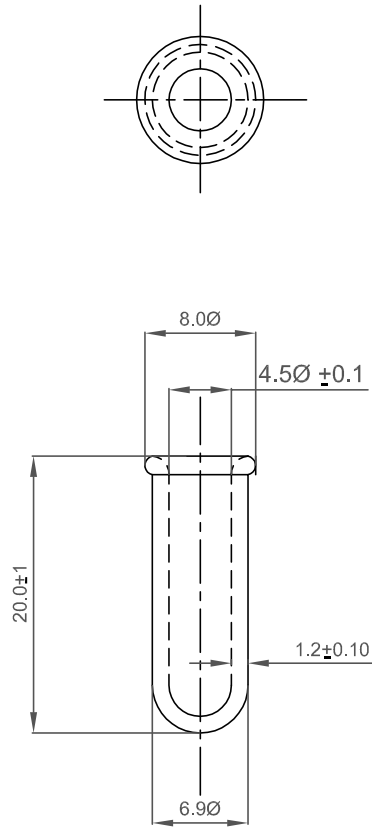

MATERIAL:-

GOOD COMMERCIAL QUALITY RUBBER SOLUTION OR LATEX DISPERSION SUITABLY COMPOUNDED FOR PRODUCING A VULCANISED RUBBER HAVING GOOD AGEING PROPERTIES. THE MIX USED SHALL CONTAIN NOT LESS THAN 85% RUBBER HYDRO CARBON AND 1% OF ANTIOXIDANT.

ORDNANCE FACTORY BHANDARA

SLEEVE RUBBER

(FOR SEALING END OF CORD DETONATING 'A')

DATE :- 25 - 2 - 70

SCALE :- 2 : 1

DRAWN BY :-

DRG NO.

TRACED BY :- Sd / -

CHECKED BY :- Sd / -

OFBA / CORDT / 22

APPROVED BY :-

FINAL APPROVAL

CIA KIRKEE
BASED ON DRG. NO.
IT X 223 DT. 10.7.69

Sd / -

MANAGER / INSP.

GENERAL MANAGER