

ALTERATIONS		PL. OR DATE	BY	CHKD
PAINTING NOTE ADDED DIN : 023048		23/03/05	ABM	A.0
DRG TEMPLATE UPDATED		14.06.11	RSK/BSV	B.0

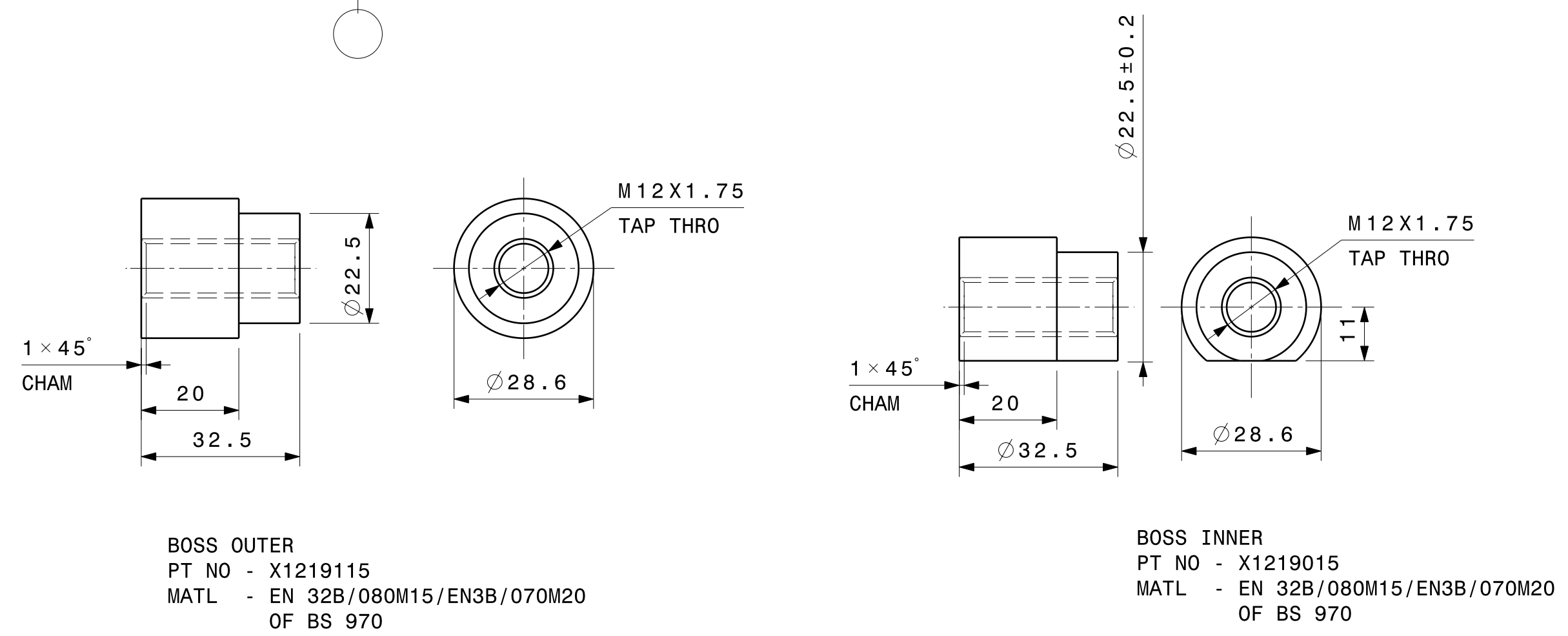
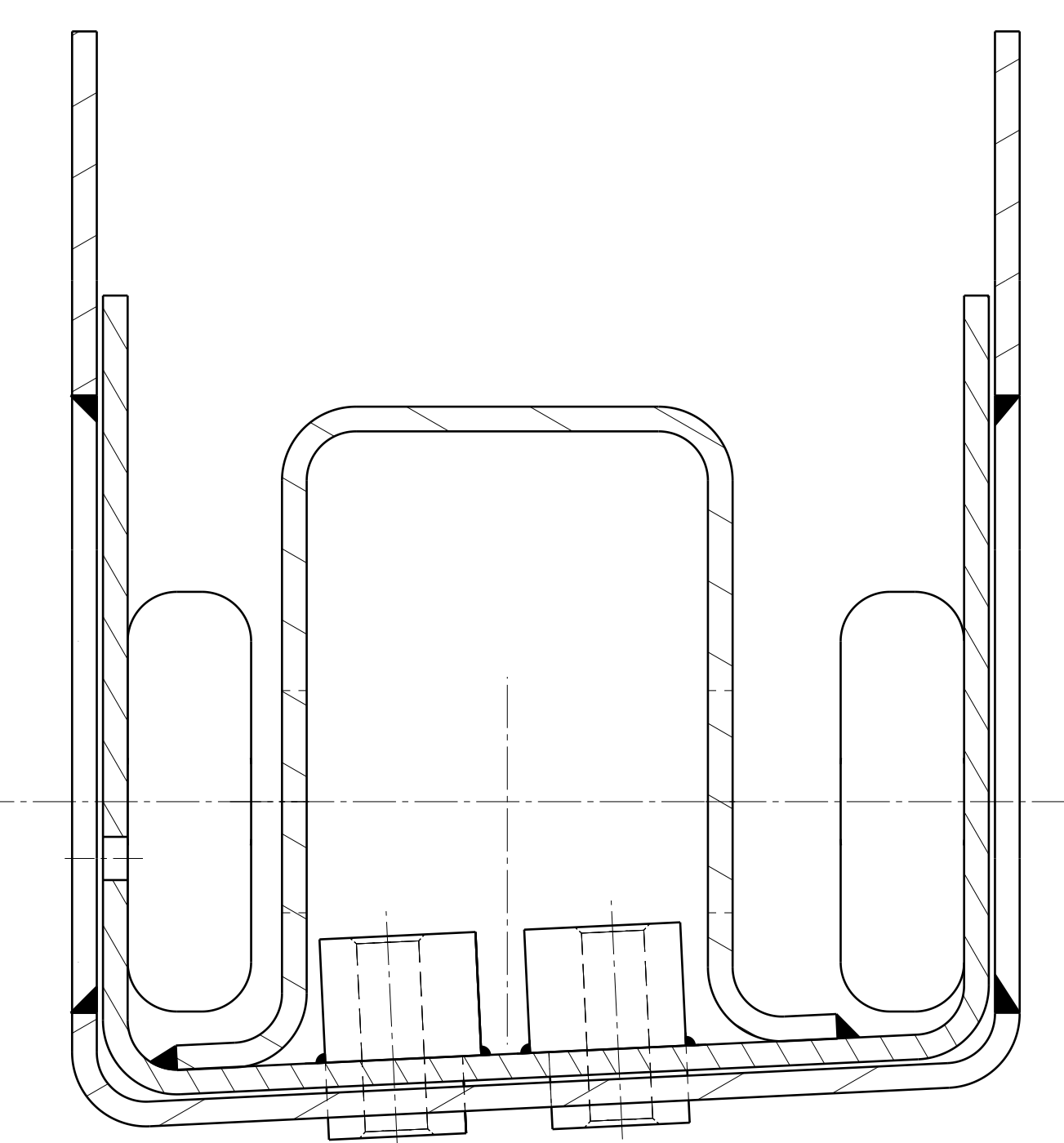
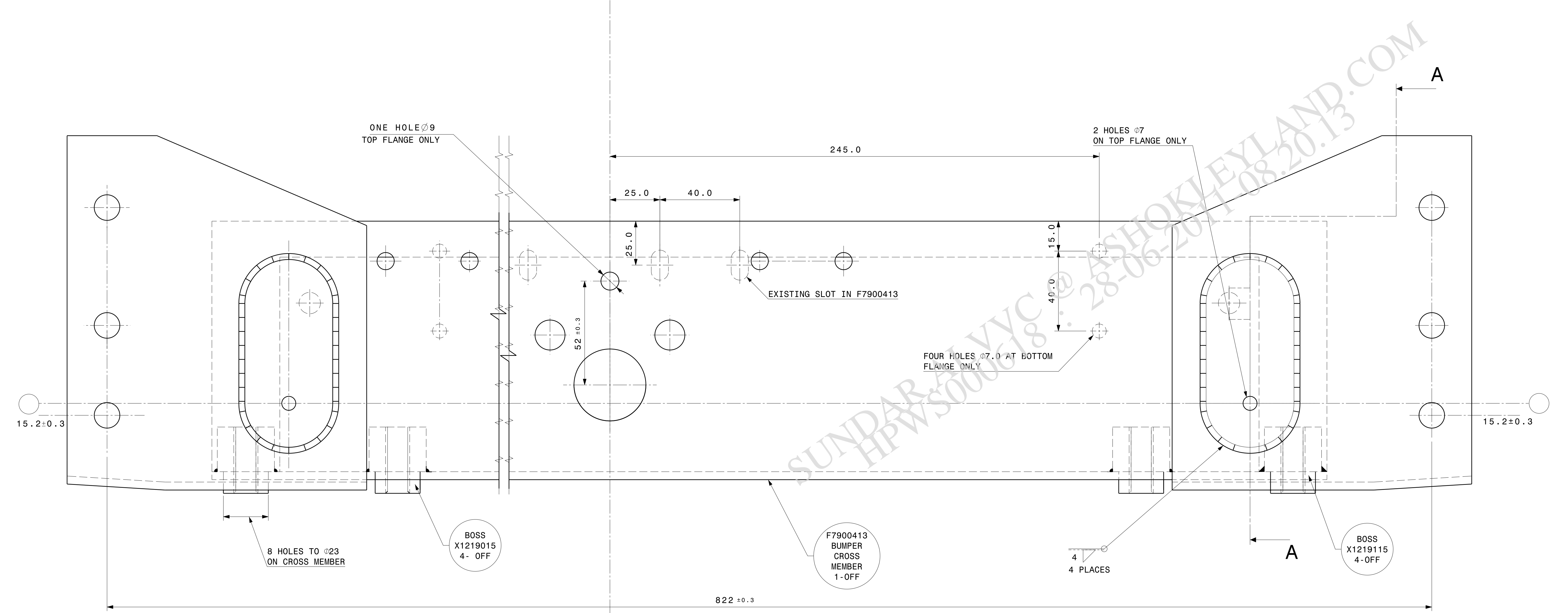
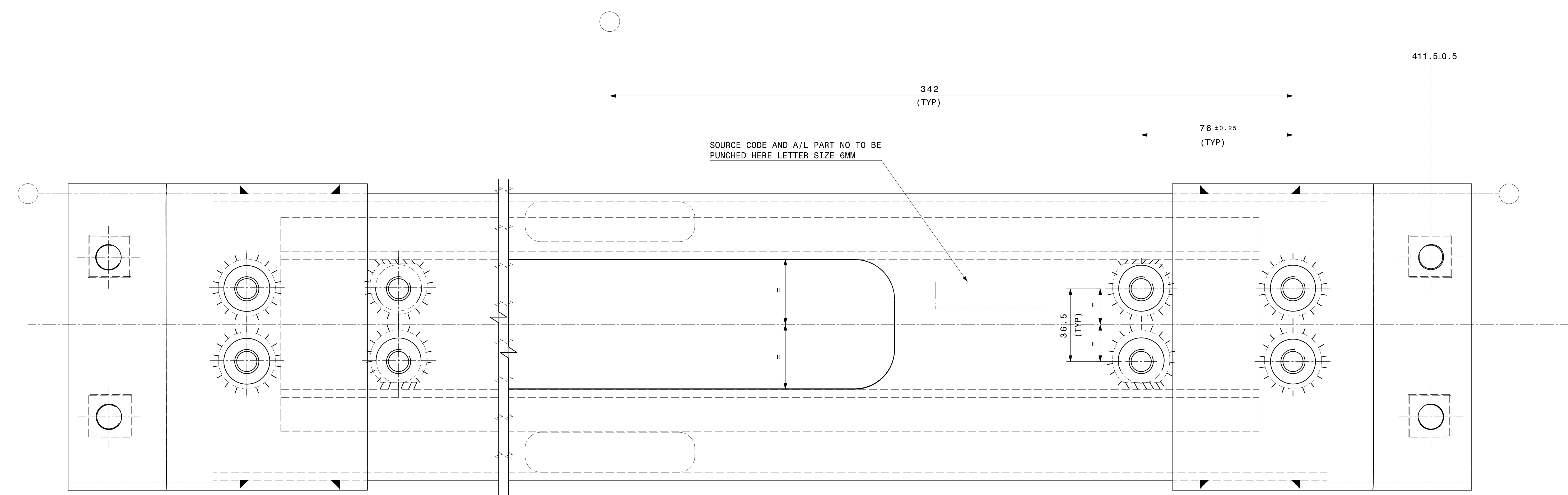

NOTE: WELDING ELECTRODE TO SPEC AWS E 6012/E 6013 OR EQUIVALENT WELDING FILLET 4mm FOR OTHER DIMENSIONS AND DETAILS REFER DRG F7900413

NOTE: THE 0-0 LINE ARE LINEAR DATUM FOR THE VIEW IN WHICH THEY APPEAR DIMNS WITHOUT ARROW HEADS SHOW DISTANCE BETWEEN EXTENSION LINE & THE PARALLEL 0-0 LINE. DIMNS WITH ARROW HEADS DO NOT PERTAIN TO THE 0-0 LINE.

NO GAP PERMITTED BETWEEN CROSS MEMBER & GUSSETS IN THE TOP & BOTTOM FLANGES

SUPPLIER CODE AND AL PT NO TO BE PROVIDED IN SUITABLE LOCATION

Q-CRITICAL	Q-SAFETY	Q-IMPORTANT. THIS DRG. CONTAINS SAFETY CHARACTERISTICS
UNLESS OTHERWISE SPECIFIED		
TOLERANCES	REFER IS:2102 ; MEDIUM FOR MACHINING AND COARSE FOR FABRICATION	
SURFACE PROTECTION	FABRICATED COMPONENTS TO BE DEGREASED, DESCALED, APPLY ZINC PHOSPHATE, APPLY EPOXY PRIMER AND APPLY ENAMEL TO MEET 300 HRS OF SALT SPRAY LIFE WHEN TESTED AS PER ASTM B117 (UNDER PELLICULAR CORROSION -- 20hr. NO BLISTERING IS ALLOWED.) MACHINED SURFACE TO BE APPLIED WITH RUST PREVENTIVE OIL TO IS:1154	
SURFACE FINISH AS PER IS:3073 (CLA VALUE)	METRIC SCREW THREADS SHALL CONFORM TO THE LIMITS AND TOLERANCES SPECIFIED IN THE CURRENT IS:4216 CLASS 6g EXTERNAL OR 6h INTERNAL.	SHARP EDGES TO BE REMOVED DIMENSIONS ARE IN MM DO NOT SCALE DRAWING

SPECIAL INSTRUCTIONS/NOTE:

(A) PAINTING DETAILS:
* TO BE PAINTED WITH ENAMEL SCAMIC GREEN CONFORM TO SHADE NO:294, IS:5. (REF DRG NO: X9715000)

SL. No.	PART NO.	DESCRIPTION	MATERIAL	QTY.
BILL OF MATERIALS				
APPEARANCE ITEM	ER-DIN	DATE		
YES	NO	ER-DIN-H5136	25/09/96	
FINISHED WEIGHT (APPROX)	REF. PT. NO.	B1085101		
	S/A. PT. NO.	A8136500		
SCALE	SUPERSEDES	F7900413		
1:1	SPEC. NO.	HAF		

AL PLM VAULT				
REVISION: B.0	DATE: 27/6/2011	STATUS: RELEASE		
STAGE: III	ER-DIN NO: ER-DIN-0007630	DATE: 27/6/2011		
ALTERED BY: sundar.alv	CHECKED BY: jna.alv	APPROVED BY: sngarajan.alv		
MED APPROVAL: visualv				
DIGITALLY SIGNED - PHYSICAL SIGNATURE NOT REQUIRED				
DRWN/ DATE	CHECKED/ DATE	MED. APPROVAL/ DATE	APPROVED/ DATE	STDS APP/ DATE
MBC 18/08/03	SN 18/08/03	CS 23/08/03	SN 18/08/03	
MATERIAL SEE DRAWING				
HEAT TREATMENT				
REMARKS				
STALLION 4X4 MARK 1V				
DESCRIPTION BUMPER - CROSS MEMBER				
PART NO.	B 8 1 3 6 5 0 7			B.0
SHEET NO	1	OF	1	AO