

1005-560047 D.S.CAT. DRAWING CONVENTIONS CONFORM TO JSS:0104  
 DIMNS. ARE IN mm. GEN. TOL. 'MEDIUM' IS:2102

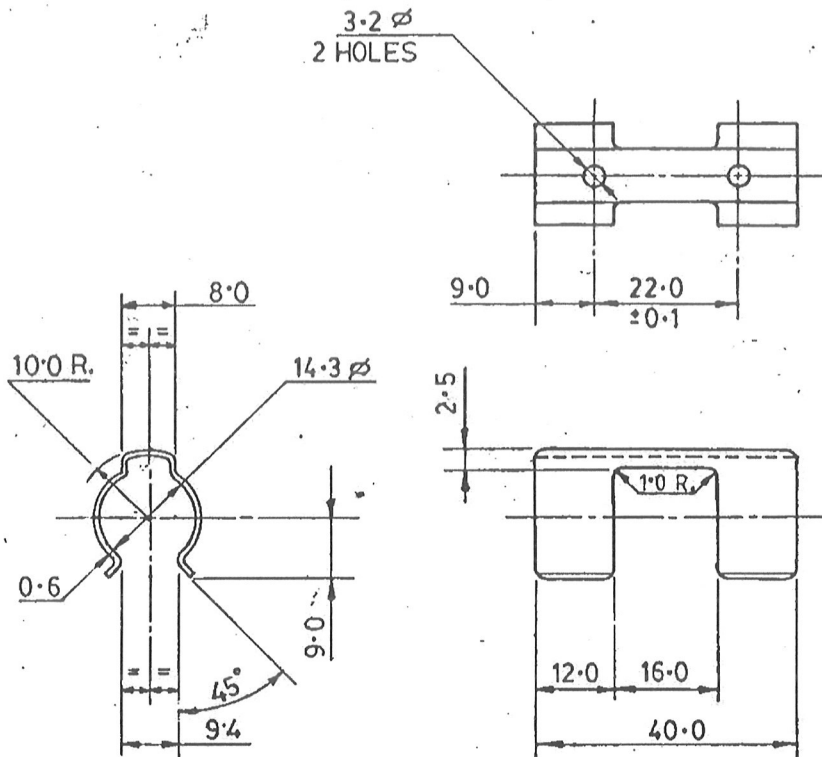

26.08.16	26920SA	MATERIAL AMENDED.	PKHARNA	1/1	JTO (D)		
27-11-10	26551-SA	IN ASSY. CQA(SA) SK-971 ADDED.	PKS-anna	1/1	JTO (D)		
19-07-10	26525SA	NSN ADDED.	1/1	JTO			
02-01-03	25638-SA	D.S. CAT. NO. 1005-560047 ADDED. & IN ASSY COLUMN D.S. CAT. NO. 1005-560045 WAS CQA(SA)	1/1	JTO			
	DATE AUTHY	BRIEF RECORD				ZONE	G.O

NSN: B1/1005-72-0000047

NOTE :- REMOVE ALL SHARP EDGES & BURRS

4-9-2001	25114-SA	DRG. PROV. SEALED			
DATE	AUTHY.	BRIEF RECORD	ZONE	I/C;D.O.	G.O.
SEALED :- PROV. DC. NO. 25 114-SA DT. 4.9.2001				SIGN.	
DRN. <i>Datta</i>	CHD. M.K.R.C.	TRD.	COMP.	AHSP: CQA(SA) ICHAPUR	
SCALE:- 1:1		EST. MASS.		ASSY. 1005-560046 & CQA(SA) SK-971	
DT. 3.9.01	<i>Amr</i> I/C;D.O.	APPROVED	DT. 3.9.01	<i>MA-8</i> DAC. CQA(SA)	
MATERIAL:- IS:7226-1974 DESIGNATION C80				DGNR'S ARDE SK.3143/112 Sht 2	
HT./HARDNESS:-400 TO 450 HV.				PART. No.	
PROTECTIVE PHOSPHATED TO SPECN. JSS:0465-01-FINISH :- 1988 CLASS II (ACCELERATED), OIL FINISH.				DRG.No. CQA(SA)SK. 454/8/2	
NOMENCLATURE :- CLAMP GUARD HAND (UPPER)				D.S.CAT. No. 1005-560047	

D.S.CAT. 1005-560701

DRAWING CONVENTIONS CONFORM TO JSG:0104  
DIMNS ARE IN mm. GEN. TOL. 'MEDIUM' IS:2102

FLAT HEAD RIVET 3Ø x 12 TO IS:2155 - 1962 — 2  
RIVET HEAD SHOULD BE LOWER THAN THE SURFACE.

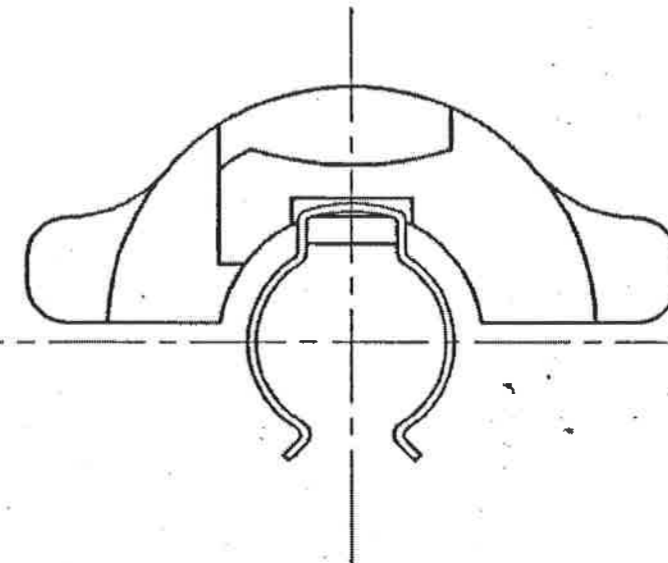
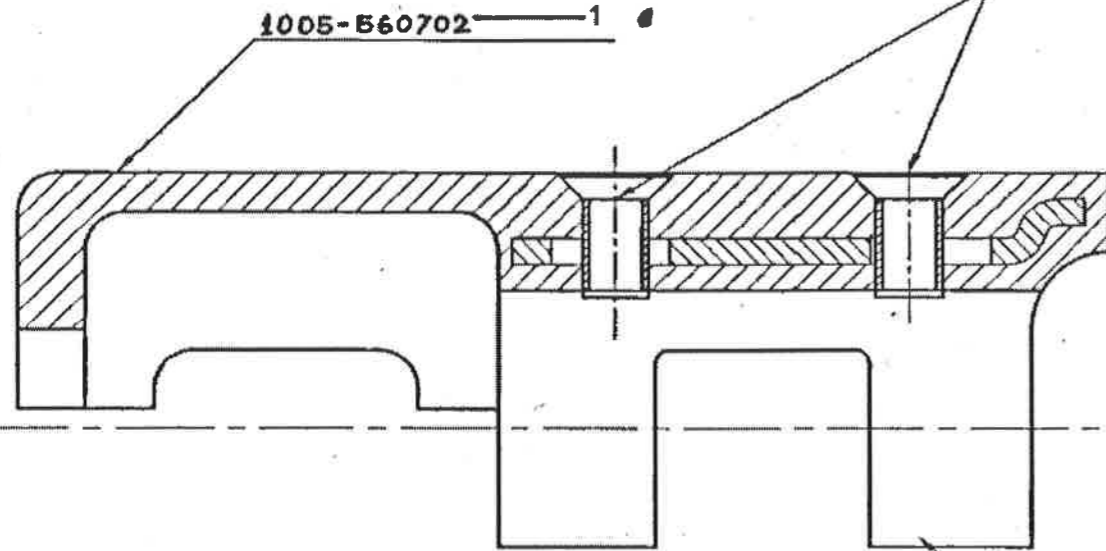

1005-560047 — 1

08-03-11		26580-SA	1005-560702 WAS CQA(SA)SK-972	A/2	DRN. 26580	CHD.	TRD.	COMP.	AHSP. CQA(SA) ICHAPUR
04-03-11		26578-SA	D.S. CAT. NO. ADDED		SCALE :- 2 : 1		EST. MASS		ASSY. 1005-560619 sub-1
27-12-10		26550-SA	ASSY. NO. 1005-560619 sub-1 WAS CQA(SA)SK-760 & DGNR'S REF. 1005-560617 WAS CQA(SA)SK-743		DT. 17-11-09	I/C. DO.	APPROVED	DT. 17-11-09 FOR CQA(SA)	DGNR'S. REF. 1005-560617
17-11-09		26474-SA	DRG. PROV. SEALED.		MATERIAL :-				PART No.
DATE. AUTHY.			BRIEF RECORD	ZONE	H.T./HARDNESS :-				DRG. No. CQA(SA)SK-971
SEALED :-			PROV. DC. No. 26474-SA, DT. 17-11-09	SIGN.	PROTECTIVE :-				D.S.CAT. No. 1005-560701
NOIMENCLATURE :-					<b>GUARD HAND UPPER ASSY.</b>				
					FINISH				

1005-560702

DRAWING CONVENTION CONFORM TO JSG 0104  
DIMNS ARE IN mm. GEN. TOL. 'MEDIUM' IS 2102

LETTER SIZE 4 x 3 & 2 mm.  
GAP BETWEEN TWO LETTERS

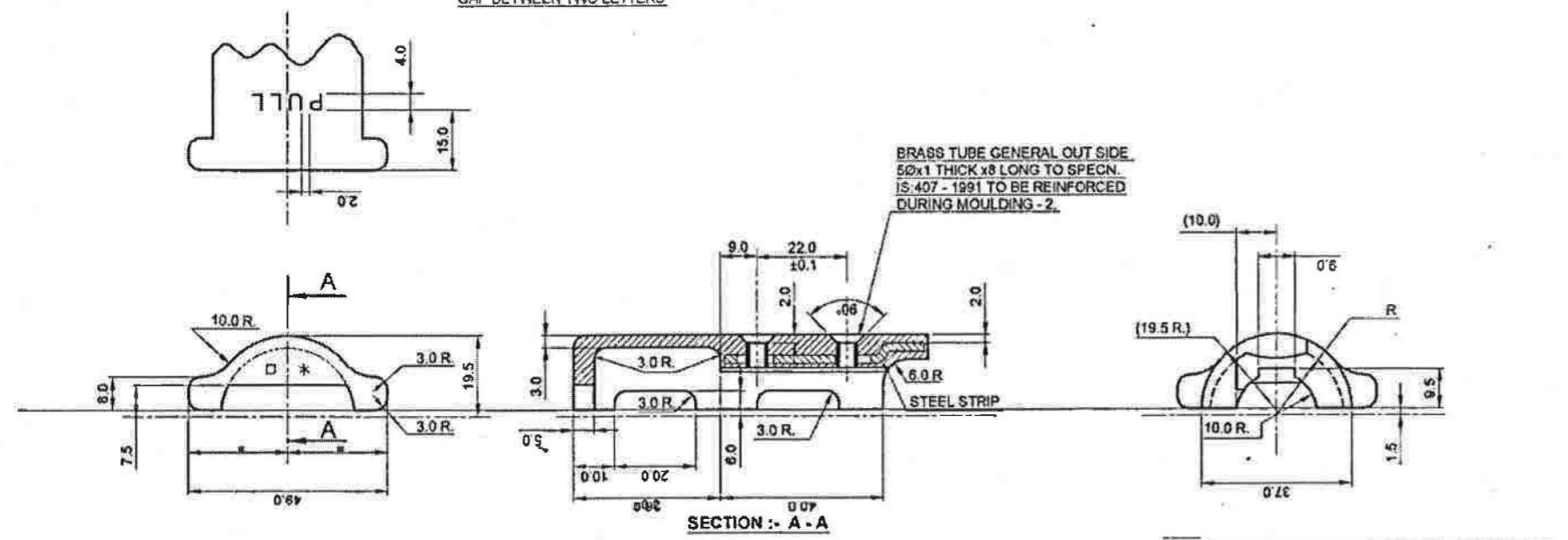

MARKING AT ZONE B/2 ON SAMPLE BY MOULDING  
 Yr. OF Mfg.  
 \* MANUFACTURER'S CODE  
 Ⓢ DS CAT. NO.  
 'PULL' AT ZONE A/2 TO BE MARKED BY MOULDING

FOR MATL, PHYSICAL PROPERTIES & TESTS REFER SPECN. NO. ARDE/SPEC/543 (PROV.)

MATL:- **GLASS FIBER FILLED PHENOLIC MOULDING MATERIAL TO SPECN. IND/ME/951 (PROV.)**  
Grd. 'A' OR 'B'

COLOUR OF RAW MATERIAL :- TO IS SPECIFICATION 5 : 2007 No. 695 DARK BLUE GREY, ADDITION OF PIGMENT NOT PERMITTED.

COATING:- VAPOCURE COATING IN DARK BLUE GREY COLOUR CODE 695 TO SPECIFICATION IS 5 : 2007. OR MRF SHADE No. BLACK - 600 WITH MATT FINISH.  
\* MANUFACTURER'S SYMBOL SIZE 4.0 mm.

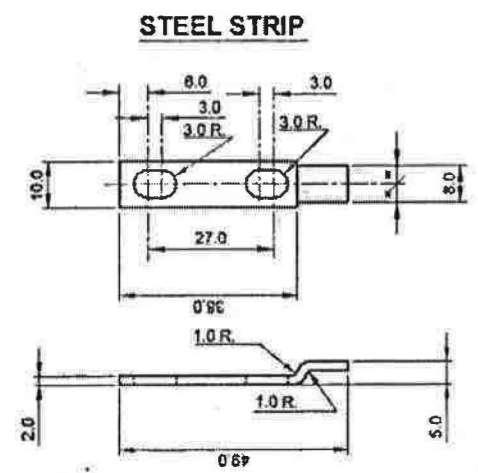

MATL :- STEEL STRIP B.S. 1449 Pt.1 1983 GRADE 80CS SEC - 4.

PROTECTIVE FINISH :- PHOSPHATED TO SPECN JSS-0465-01-1994 CLASS II (ACCELERATED) OIL FINISH.

HARDNESS :- 400 TO 450 HV.

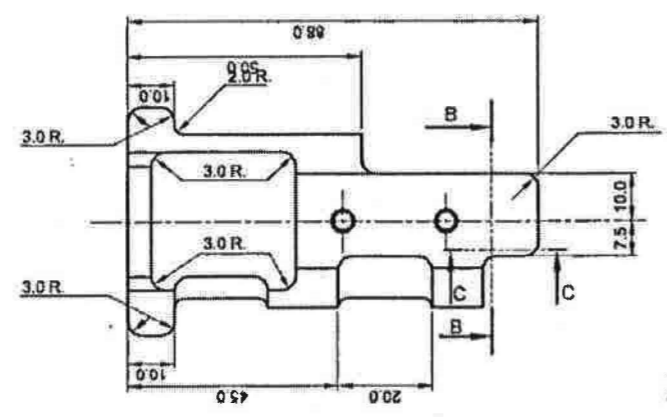

PART SECTION :- 'C - C'

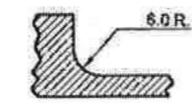

PART SECTION :- 'B - B'

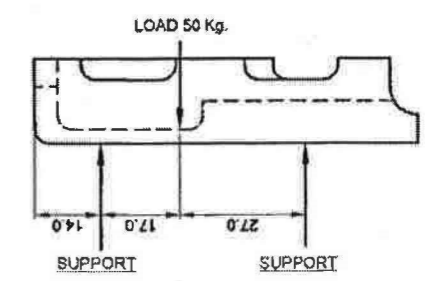
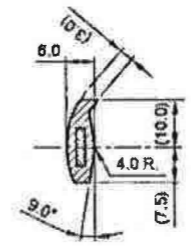

METHOD OF TESTING ON FINAL STORES

DC No. 26910-SA, DT. 09-08-2016		DRN. #markar	CHD.	TRD.	COMP.	AHSP. CQA(SA), ICHAPUR
		SCALE :- 1:1		EST. MASS APPROVED		ASSY. 1005-560701
08-03-11	26580-SA	D.S.CAT. No. ADDED & IN ASSY. 1005-560701 WAS CQA(SA)SK-971		DT. 19-11-09	IC.D.O. DT. 19-11-09	FOR CQA(SA)
27-11-10	26550-SA	DGNR'S REF. 1005-560618 WAS CQA(SA)SK-744		MATERIAL :- AS STATED		DGNR'S REF. 1005-560618
19-11-09	26475-SA	MATL. COLOUR; PROTECTIVE FINISH AMENDED & DRG. PROV. SEALED		H.T./HARDNESS :- AS STATED		PART No.
DATE AUTHY.		BRIEF RECORD		ZONE IC.D.O. G.O.		DRG. No. CQA(SA)SK-972
SEALED :- PROV. DC. NO. 26475-SA DT 19 11 09		SIGN.		PROTECTIVE FINISH :- AS STATED		D.S.CAT. No. 1005-560702
NOMENCLATURE :-		GUARD HAND UPPER				
		(STEEL STRIP)				