

NOTES:

1. FINISH $\sqrt{3.2}$ ALL OVER.
2. BREAK EDGES 0.076 + 0.305 UNLESS OTHERWISE SPECIFIED.
3. MATERIAL: STEEL, ASTM A108: 1045, 1050, 10L50, 1137 THRU 1151 OR 11L37 THRU 11L51
4. HEAT TREATMENT: HEAT AT 816-860°C, OIL QUENCH, TEMPER 1 HOUR MIN. TO HARDNESS SPECIFIED (RH A70-74).
5. FINAL PROTECTIVE FINISH: FINISH 5.3.1.2 OR 5.3.2.2 OF MIL-STD-171.
6. ASME Y14.5M-1994 APPLIES.

REVISIONS				
ZONE	REV.	DESCRIPTION	DATE	APPROVED
	A	CREATE DRAWING	4/8/2015	G. HERSHBERGER
	B	CHANGED CAGE CODE TO DDW '1V2A7'	5/23/2015	G. HERSHBERGER
	C	ADDED 1045 MATERIAL AS AN ALTERNATE	6/2/2015	G. HERSHBERGER

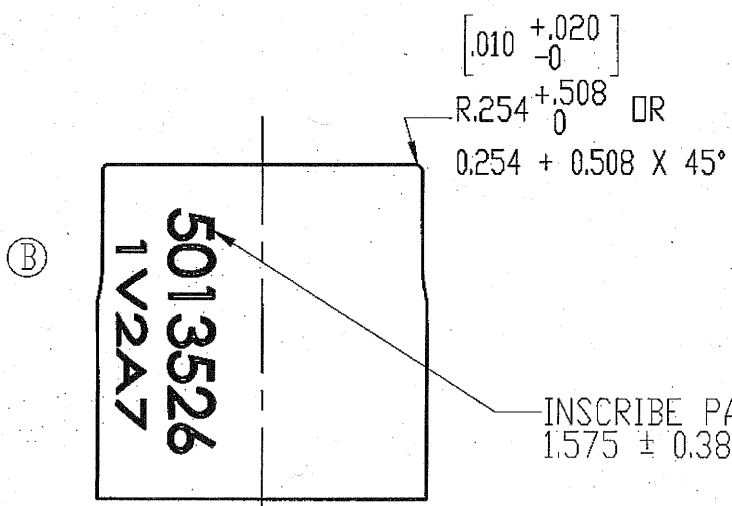

प्रमाणित रूप से प्रमाणित
 Provisionally Approved
24 AUG 2021
 डिजाइनर / Sig
 For model (AP1)

UN CONTROLLED COPY
 CERTIFIED CORRECT COPY OF APPROVED
 DRAWINGS AT THIS DATE, 29.09.2021
 DESIGN & DRAWING OFFICE,
 ORDNANCE FACTORY, TIRUCHIRAPPALLI-620 016

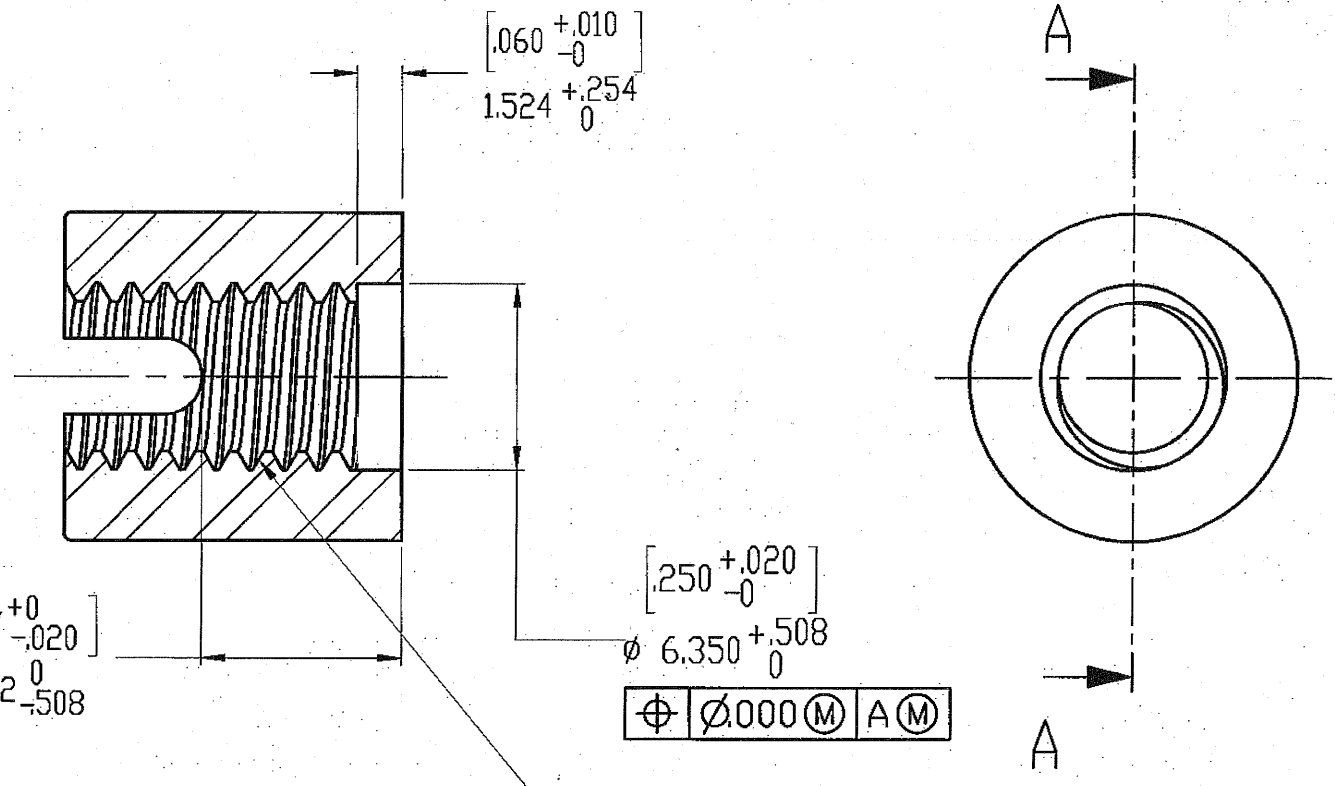

SECTION A-A

.250-22 UNS-3B-MOD
 MAJOR DIA. .2500 MIN.
 PITCH DIA. .2205 +.0038
 MINOR DIA. .2004 +.0049-MOD
 -A- MINOR DIA.

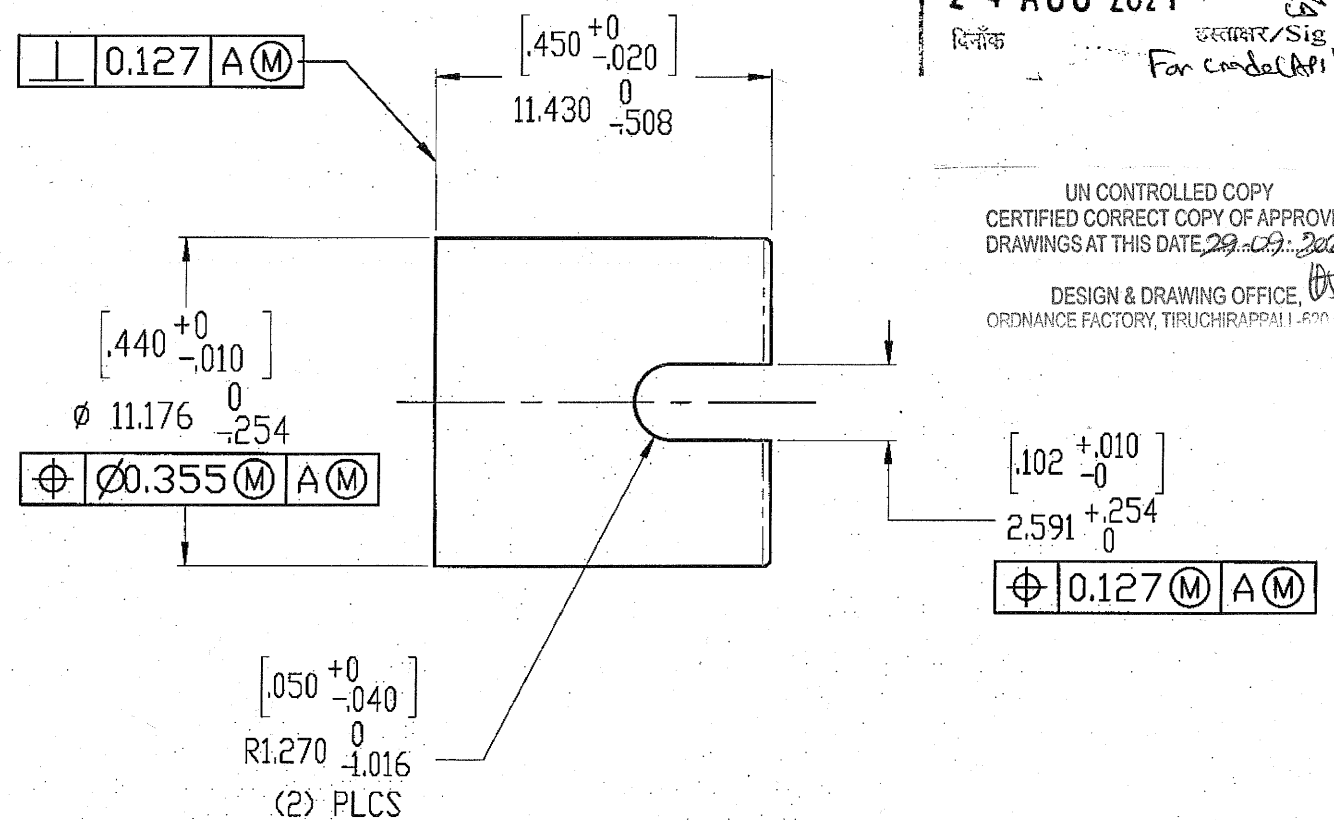

ITAR CONTROLLED THIS DOCUMENT IS CONTROLLED UNDER THE ITAR. IT MAY NOT BE PROVIDED TO A NON-U.S. RESIDENT WITHOUT THE WRITTEN APPROVAL OF THE U.S. GOVT. VIOLATIONS WILL RESULT IN CIVIL OR CRIMINAL PENALTIES. PROPRIETARY AND CONFIDENTIAL THE INFORMATION CONTAINED IN THIS DRAWING IS THE SOLE PROPERTY OF OHIO ORDNANCE WORKS, INC. ANY REPRODUCTION IN PART OR AS A WHOLE WITHOUT THE WRITTEN PERMISSION OF OHIO ORDNANCE WORKS, INC. IS PROHIBITED.	UNLESS OTHERWISE SPECIFIED	NAME	DATE	OHIO ORDNANCE WORKS, INC. NUT, BOLT LATCH ROD, DDW50BMG SIZE B 5013526 REV C SCALE: 4:1 WEIGHT: SHEET 1 OF 1	
	DIMENSIONS ARE IN MM/(INCHES) ALL THREAD DIM. ARE IN INCHES	DRAWN	PMD		04/08/15
	TOLERANCES: FRACTIONAL ANGULAR: MACH ± BEND TWO PLACE DECIMAL ±0.25 THREE PLACE DECIMAL ±0.127	CHECKED			
	INTERPRET GEOMETRIC TOLERANCING PER:	ENG APPR.			
	MATERIAL	MFG APPR.			
FINISH:	Q.A.				
DO NOT SCALE DRAWING	COMMENTS:				