

BILL OF MATERIAL			
Item No.	Description	OFBH Drg. No.	Qty
1	Handle	OFBH/SK/1543	1
2	Handle clip	OFBH/SK/1544	1

**NOTE :-**  
HANDLE SHOULD ROTATE FREELY INSIDE HANDLE CLIP.

**NOTE:-**  
Samples should got approved before bulk supply. Drawing is for reference.

THIS DRAWING IS THE PROPERTY OF O.F. BHUSAWAL MINISTRY OF DEFENCE, GOVT. OF INDIA. IT SHOULD NOT BE COPIED / REPRODUCED IN ANY WAY.

<b>TITLE :-</b> HANDLE AND HANDLE CLIP SUB ASSEMBLY for Metallic Container for OF Bhandara		2021	NAME	SIGN	DATE
NOTE :- 1) ALL DIMENSIONS ARE IN MM. 2) UNSPECIFIED TOLERANCES AS PER IS 2102 (MED).		JWM/SHOP	N. PRAKASH	<i>[Signature]</i>	21/3
		DGN./DRN.	R.R.SAHARE	<i>[Signature]</i>	21/3
		JWM/CHD	N.TADVI	<i>[Signature]</i>	21/3
		HOS/DO	V.KANDWAL	<i>[Signature]</i>	21/3
		DIV.O/DO	AKASH VERMA	<i>[Signature]</i>	21/3
SCALE :- NTS		ORDNANCE FACTORY BHUSAWAL		ID NO:- Drg4/ Metallic container	
SIGN.				DRG. NO:- OFBH/SK/1535	

R.NO.	DATE	AUTHORITY	REVISION	SIGN.
1				
2				
3				
4				

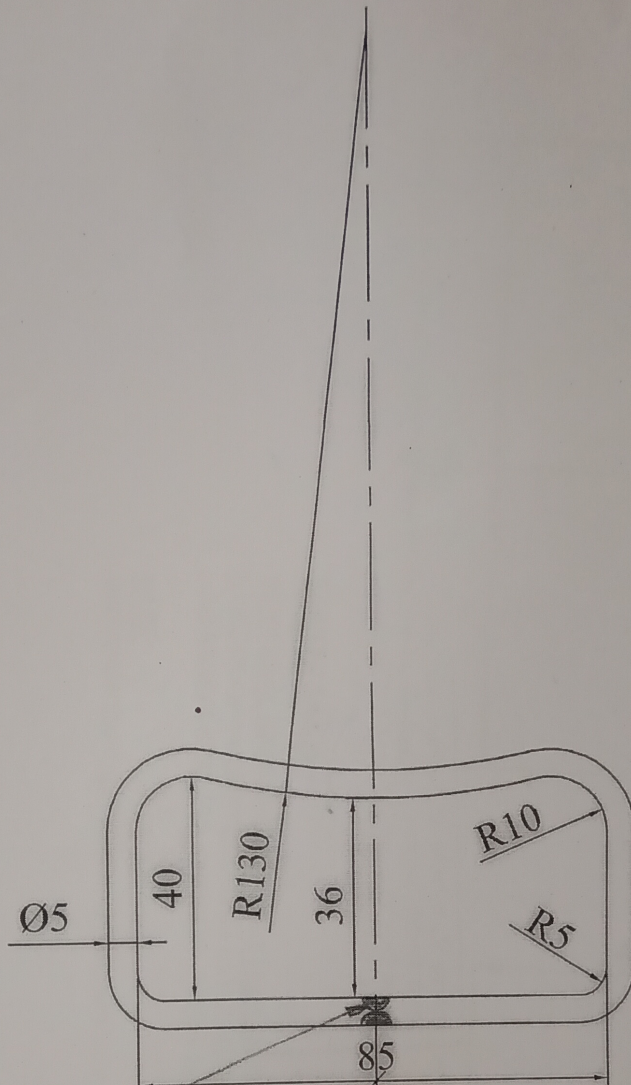

ENDS OF HANDLE TO BE BUTTED & WELDED

**MATERIAL:-** BAR STEEL TO SPEC IS 2062:1992 Gr.Fe410 WB.

**NOTE:-** Samples should got approved before bulk supply.  
Drawing is for reference.

THIS DRAWING IS THE PROPERTY OF O.F.BHUSAWAL  
MINISTRY OF DEFENCE, GOVT. OF INDIA., IT SHOULD NOT  
BE COPIED / REPRODUCED IN ANY WAY.

TITLE :-

**HANDLE**

for Metallic Container for OF Bhandara

NOTE :- 1) ALL DIMENSIONS ARE IN MM.  
2) UNSPECIFIED TOLERANCES AS PER IS 2102 (MED).

SCALE: NTS

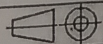

ऑर्डनेंस फैक्टरी भुसावल  
ORDNANCE FACTORY BHUSAWAL

2021	NAME	SIGN	DATE
JWM/SHOP	N.PRAKASH	<i>[Signature]</i>	27/3
DRG./DRN.	R.R. SAHARE	<i>[Signature]</i>	27/3
JWM/CHD.	N.TADVI	<i>[Signature]</i>	27/3
JWM/HOS/DO	V. KANDWAL	<i>[Signature]</i>	27/3
GO/DO	A. VERMA	<i>[Signature]</i>	27/3

ID NO.: DRG\_4/Metallic container

DRG. NO.: OFBH /SK/1543

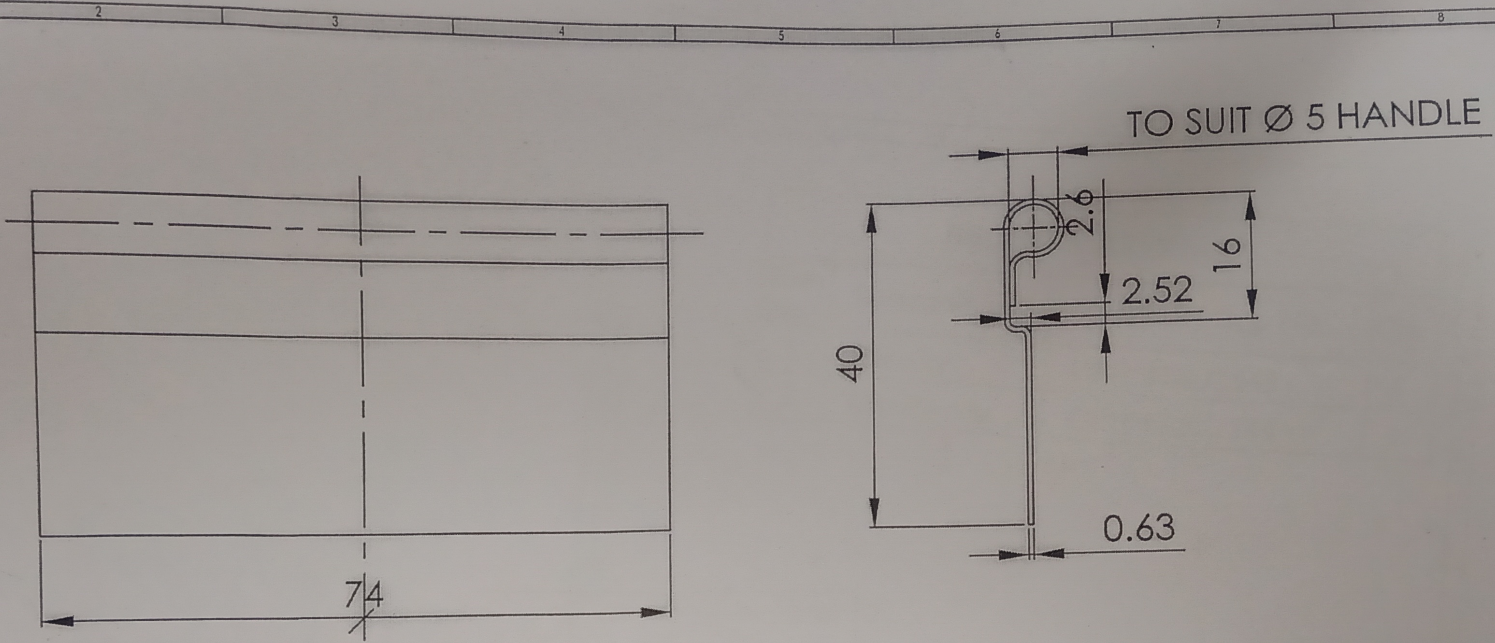

**MATERIAL :-**

SHEET STEEL FROM CONTINUOUS LINES OF CLASS 1 OF THICKNESS 0.63MM  
 (WEIGHT OF 1 m2 OF COATING LAYER, APPLIED FROM TWO SIDES , g- FROM 258 TO 570  
 ; COATING THICKNESS , MICRON - FROM 18 TO 40.

**NOTE:-**

Samples should got approved before bulk supply. Drawing is for reference.

THIS DRAWING IS THE PROPERTY OF OF BHUSAWAL  
 MINISTRY OF DEFENCE, GOVT OF INDIA. IT SHOULD NOT  
 BE COPIED / REPRODUCED IN ANY WAY.

TITLE :-		2021	NAME	SIGN	DATE
HANDLE CLIP for Metallic Container for OF Bhandara		DGN/DRN.	R.R.SAHARE	<i>[Signature]</i>	25/3
		JWM/CHD.	N.TADVI	<i>[Signature]</i>	25/3
NOTE :- 1) ALL DIMENSIONS ARE IN MM. 2) UNSPECIFIED TOLERANCES AS PER IS 2102 (MED).		JWM/HOS/DO	V.KANDWAL	<i>[Signature]</i>	25/3
		GO/DO	A.VERMA	<i>[Signature]</i>	25/3
		JWM/SHOP	N. PRAKASH	<i>[Signature]</i>	25/3
SCALE :- NTS		ORDNANCE FACTORY BHUSAWAL		ID NO: Drg/Al Metallic container	
DRG. SEALED :-				DRG.NO: OFBH/SK/1544	

R.NO.	DATE	AUTHORITY	REVISION	SIGN.
-------	------	-----------	----------	-------