

VETTED

A. D. Sadalge
 A D SADALGE,
 ASST DIRECTOR,
 MISSILE SYSTEM QUALITY
 ASSURANCE AGENCY
 MINISTRY OF DEFENCE
 GOVT. OF INDIA
 C/o. DRDL, KANCHANBAGH,
 HYDERABAD - 500 058.

Certified for AKASH Production
 and issued to BDL
D. Subba Rao
 11 SEP 2014
 D.V. Subba Rao
 Head, Akash-TTG

"No Change Note. Amendment is valid
 without approval concurrence of
 Principal Director, MSQAA after
 vetting of this document / drawing."

SECTION A-A

Sl No	Nomenclature	Drg / Spec No	Qty	Rev	Material
4	BELT REINFORCEMENT	RPD/AK/CA/01 03 03 04	2	1	COTTON BELT
3	TOP LEATHER RING FOR BELT ASSY	RPD/AK/CA/01 03 03 03	6	1	LEATHER
2	BOTTOM LEATHER DISC FOR BELT ASSY	RPD/AK/CA/01 03 03 02	2	1	LEATHER
1	BELT	RPD/AK/CA/01 03 03 01	6	1	COTTON

DEVIATION FOR UNTOLERANCED DIMENSIONS TO CONFORM TO SPEC. IS : 2102, MEDIUM (PART 1 & 2) : 1993		DRAWN TO SPEC. IS : 10714-1983(R 1999), IS : 10714 (PART 20) : 2001 & IS : 10714 (PART 21) : 2001 AND DRDL NOTE SHT. 1 & 2	
SCALE: 1:5	MATL:	<i>G. Satyanarayana</i> TECH. OFFICER	
DIMENSIONS ARE IN mm.	FINISH:		
DRN	DATE	NAME	
DRN	21-10-11	G.S.RAJU	
MASS:	1.615 kg	<i>[Signature]</i> APPD (DGN)	<i>[Signature]</i> APPD (DRG)
BELT ASSY		ASSY DRG No. RPD/AK/CA/01 03 00 00	
Defence Research & Development Laboratory HYDERABAD		DRG. No. RPD/AK/CA/01 03 03 00	

REVISION	R.No.	DATE	AUTHORITY	ZONE	BRIEF RECORD	INITIALS
1	1	06-06-13	S&SRPD		1. Sl.No 1,2,3 &4 is Revised.	

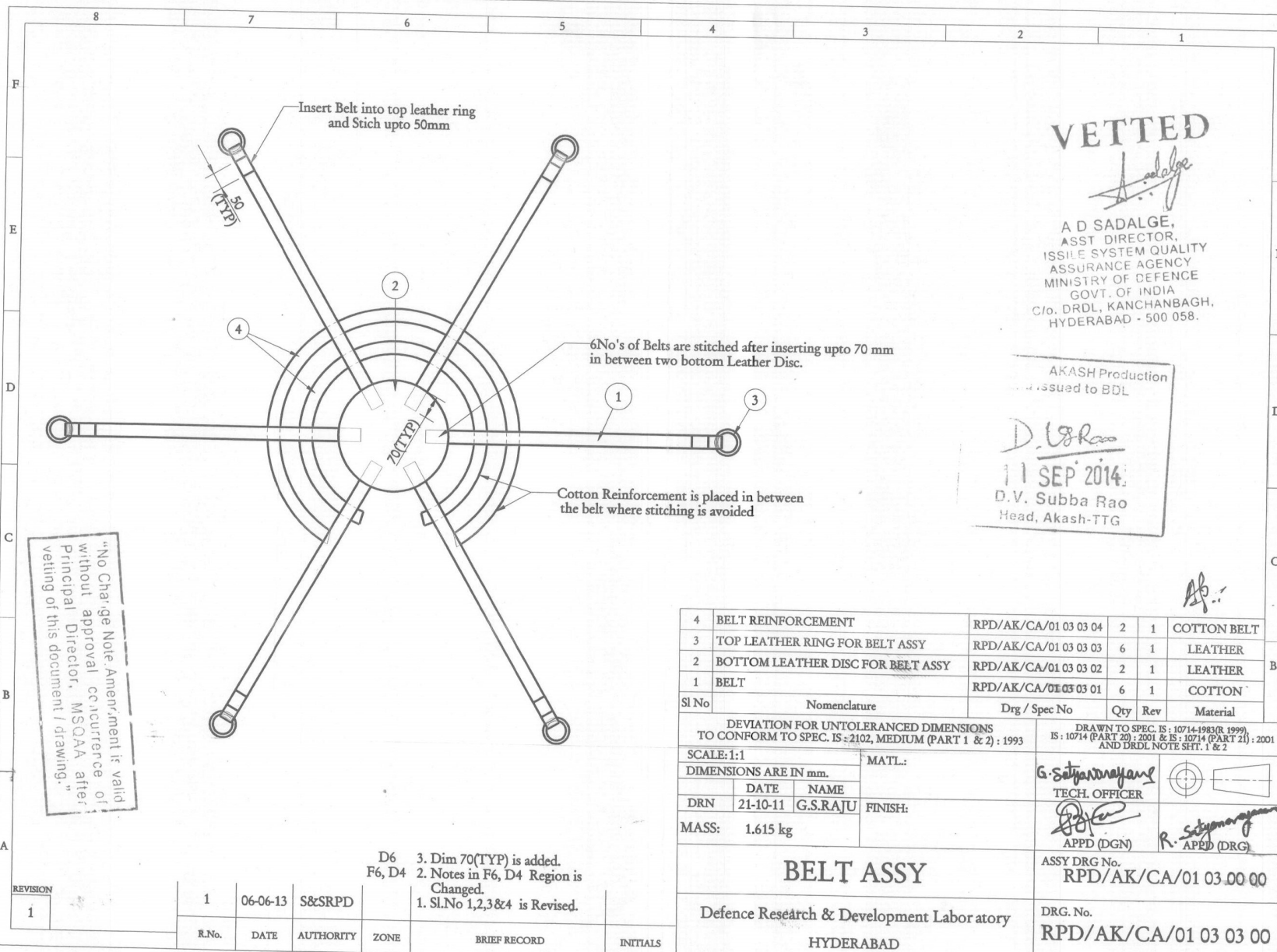

VETTED

A. Sadalge
 A D SADALGE,
 ASST DIRECTOR,
 MISSILE SYSTEM QUALITY
 ASSURANCE AGENCY
 MINISTRY OF DEFENCE
 GOVT. OF INDIA
 C/o. DRDL, KANCHANBAGH,
 HYDERABAD - 500 058.

AKASH Production
 Issued to BDL
D.V. Subba Rao
 11 SEP 2014
 D.V. Subba Rao
 Head, Akash-TTG

"No Charge Note Amendment is valid without approval concurrence of Principal Director, MSQAA after vetting of this document / drawing."

Sl No	Nomenclature	Drg / Spec No	Qty	Rev	Material
4	BELT REINFORCEMENT	RPD/AK/CA/01 03 03 04	2	1	COTTON BELT
3	TOP LEATHER RING FOR BELT ASSY	RPD/AK/CA/01 03 03 03	6	1	LEATHER
2	BOTTOM LEATHER DISC FOR BELT ASSY	RPD/AK/CA/01 03 03 02	2	1	LEATHER
1	BELT	RPD/AK/CA/01 03 03 01	6	1	COTTON

DEVIATION FOR UNTOLERANCED DIMENSIONS TO CONFORM TO SPEC. IS : 2102, MEDIUM (PART 1 & 2) : 1993
 DRAWN TO SPEC. IS : 10714-1983(R 1999)
 IS : 10714 (PART 20) : 2001 & IS : 10714 (PART 21) : 2001
 AND DRDL NOTE SHEET. 1 & 2

SCALE: 1:1	MATL.:	<i>G. S. Raju</i> TECH. OFFICER	
DIMENSIONS ARE IN mm.			
DRN	DATE	NAME	FINISH:
MASS:	1.615 kg		

BELT ASSY
 Defence Research & Development Laboratory
 HYDERABAD
 ASSY DRG No.
 RPD/AK/CA/01 03 00 00
 DRG. No.
 RPD/AK/CA/01 03 03 00

REVISION	R.No.	DATE	AUTHORITY	ZONE	BRIEF RECORD	INITIALS
1	1	06-06-13	S&SRPD		D6 3. Dim 70(TYP) is added. F6, D4 2. Notes in F6, D4 Region is Changed. 1. Sl.No 1,2,3&4 is Revised.	

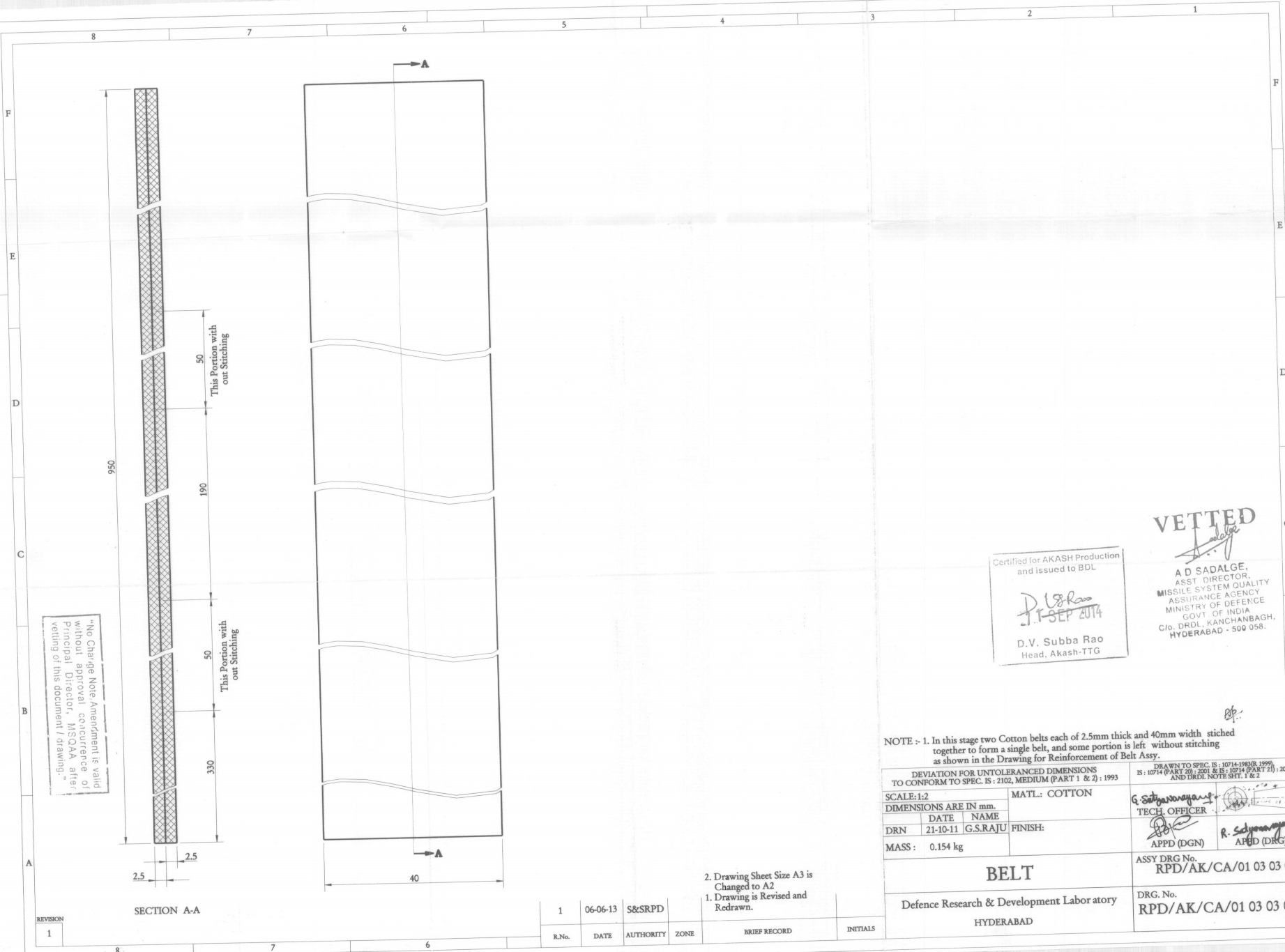

"No Change Note Amendment is valid without approval concurrence of Principal Director, MSQAA after vetting of this document / drawing."

SECTION A-A

REVISION
1

2. Drawing Sheet Size A3 is Changed to A2
 1. Drawing is Revised and Redrawn.

R.No.	DATE	AUTHORITY	ZONE	BRIEF RECORD	INITIALS
1	06-06-13	S&SRPD			

VETTED

Certified for AKASH Production and issued to BDL

 D.V. Subba Rao
 Head, Akash-TTG

A D SADALGE,
 ASST. DIRECTOR,
 MISSILE SYSTEM QUALITY ASSURANCE AGENCY
 MINISTRY OF DEFENCE
 GOVT. OF INDIA
 C/O. DRDL, KANCHANBAGH,
 HYDERABAD - 500 058.

NOTE :- 1. In this stage two Cotton belts each of 2.5mm thick and 40mm width stitched together to form a single belt, and some portion is left without stitching as shown in the Drawing for Reinforcement of Belt Assy.

SCALE: 1:2 DIMENSIONS ARE IN mm.		MATL: COTTON	DRAWN TO SPEC. IS : 10714-1983(R. 1999) IS : 10714 (PART 20) : 2001 & IS : 10714 (PART 21) : 2001 AND DRD. NOTE SECT. 1 & 2
DRN 21-10-11	G.S.RAJU	FINISH:	G. Subramanyam TECH OFFICER
MASS : 0.154 kg	APPD (DGN)	R. Subramanyam APPD (DRG)	
BELT		ASSY DRG No. RPD/AK/CA/01 03 03 00	
Defence Research & Development Laboratory HYDERABAD		DRG. No. RPD/AK/CA/01 03 03 01	

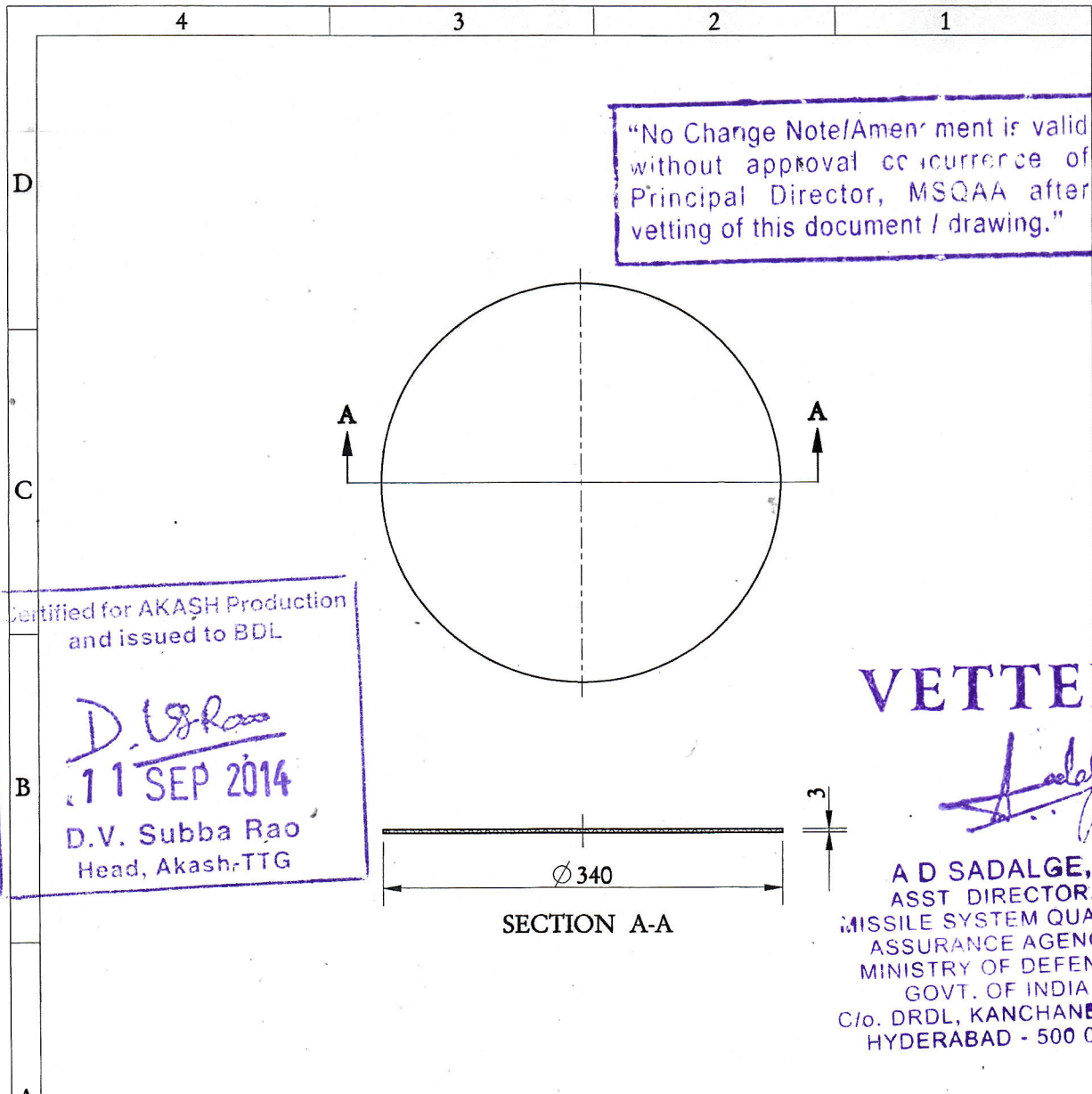

REVISION	1	06-06-13	S&SRPD		2. Dim 3 was 2.5. 1. Dim ϕ 200 Cut Feature is removed.	
	1	R.No.	DATE	AUTHORITY	ZONE	BRIEF RECORD

DEVIATION FOR UNTOLERANCED DIMENSIONS TO CONFORM TO SPEC. IS : 2102, MEDIUM (PART 1 & 2) : 1993			DRAWN TO SPEC. IS : 10714-1983(R 1999) IS : 10714 (PART 20) : 2001 & IS : 10714 (PART 21) : 2001 AND DRDL NOTE SHT. 1 & 2		
SCALE: 1:5		MATL.: LEATHER			
DIMENSIONS ARE IN mm.		G. Satyanarayana		TECH. OFFICER	
DRN	DATE	NAME	FINISH:		
21-10-11	G.S.RAJU				
MASS:	0.218 kg	APPD (DGN)		APPD (DRG)	
BOTTOM LEATHER DISC FOR BELT ASSY			ASSY DRG No. RPD/AK/CA/01 03 03 00		
Defence Research & Development Laboratory HYDERABAD			DRG. No. RPD/AK/CA/01 03 03 02		

Certified for AKASH Production
and issued to BDL

D. V. Subba Rao
11 SEP 2014
D.V. Subba Rao
Head, Akash-TTG

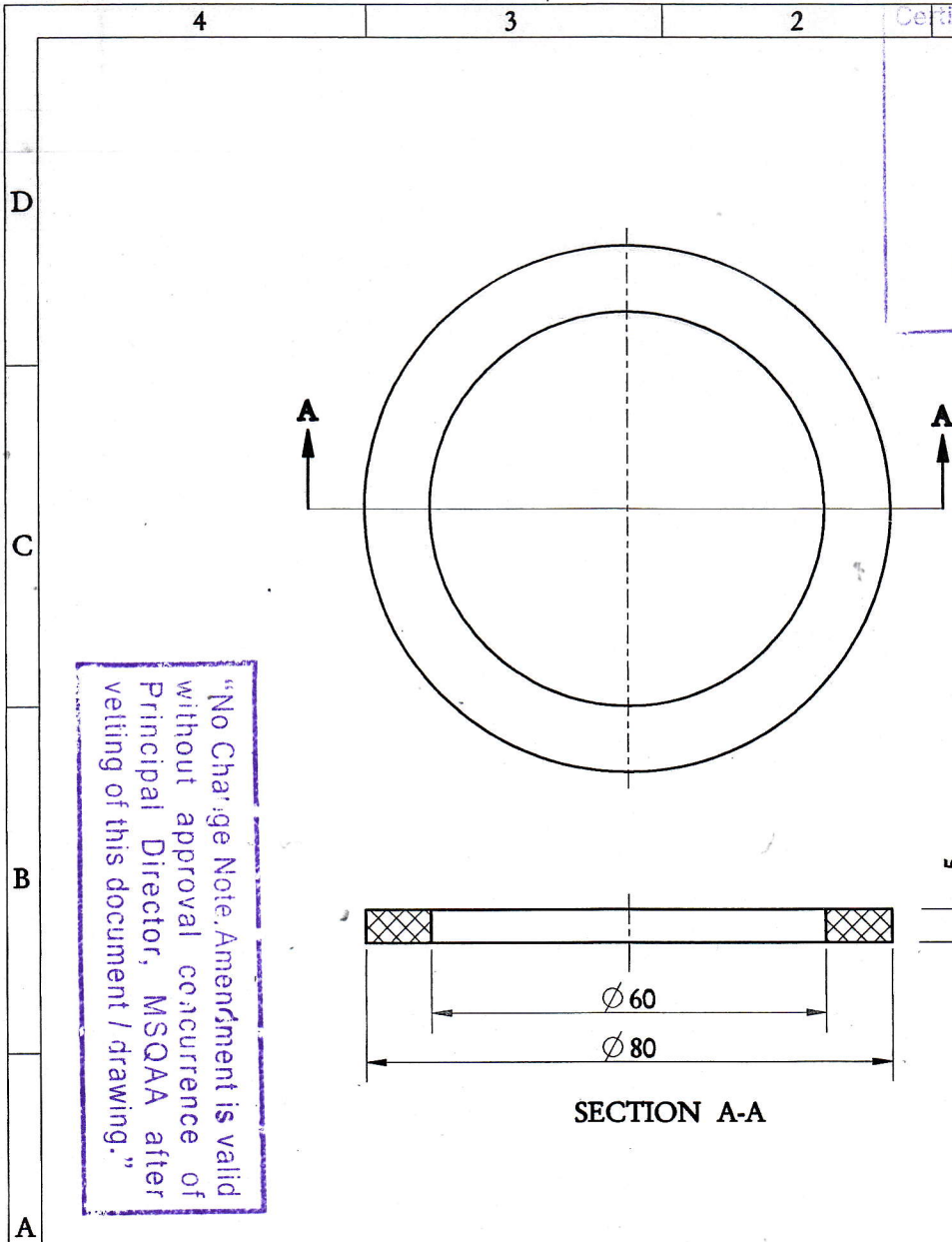

"No Change Note/Amendment is valid
without approval concurrence of
Principal Director, MSQAA after
vetting of this document / drawing."

VETTED

A D Sadalge
A D SADALGE,
ASST DIRECTOR,
MISSILE SYSTEM QUALITY
ASSURANCE AGENCY
MINISTRY OF DEFENCE
GOVT. OF INDIA
C/o. DRDL, KANCHANBAGH,
HYDERABAD - 500 058.

SECTION A-A

REVISION	1	06-06-13	S&SRPD		1. Dim's $\phi 60, \phi 80, 5$ were $\phi 80, \phi 120, 2.5$	<i>AS</i>
1	R.No.	DATE	AUTHORITY	ZONE	BRIEF RECORD	INITIALS

DEVIATION FOR UNTOLERANCED DIMENSIONS TO CONFORM TO SPEC. IS : 2102, MEDIUM (PART 1 & 2) : 1993			DRAWN TO SPEC. IS : 10714-1983(R 1999), IS : 10714 (PART 20) : 2001 & IS : 10714 (PART 21) : 2001 AND DRDL NOTE SHT. 1 & 2		
SCALE: 1:1		MATL.: LEATHER			
DIMENSIONS ARE IN mm.					
DRN	DATE	NAME			<i>G. Satyanarayana</i> TECH. OFFICER
MASS :	0.009 kg	FINISH:			<i>R. Satyanarayana</i> APPD (DRG)
TOP LEATHER RING FOR BELT ASSY			ASSY DRG No. RPD/AK/CA/01 03 03 00		
Defence Research & Development Laboratory HYDERABAD			DRG. No. RPD/AK/CA/01 03 03 03		

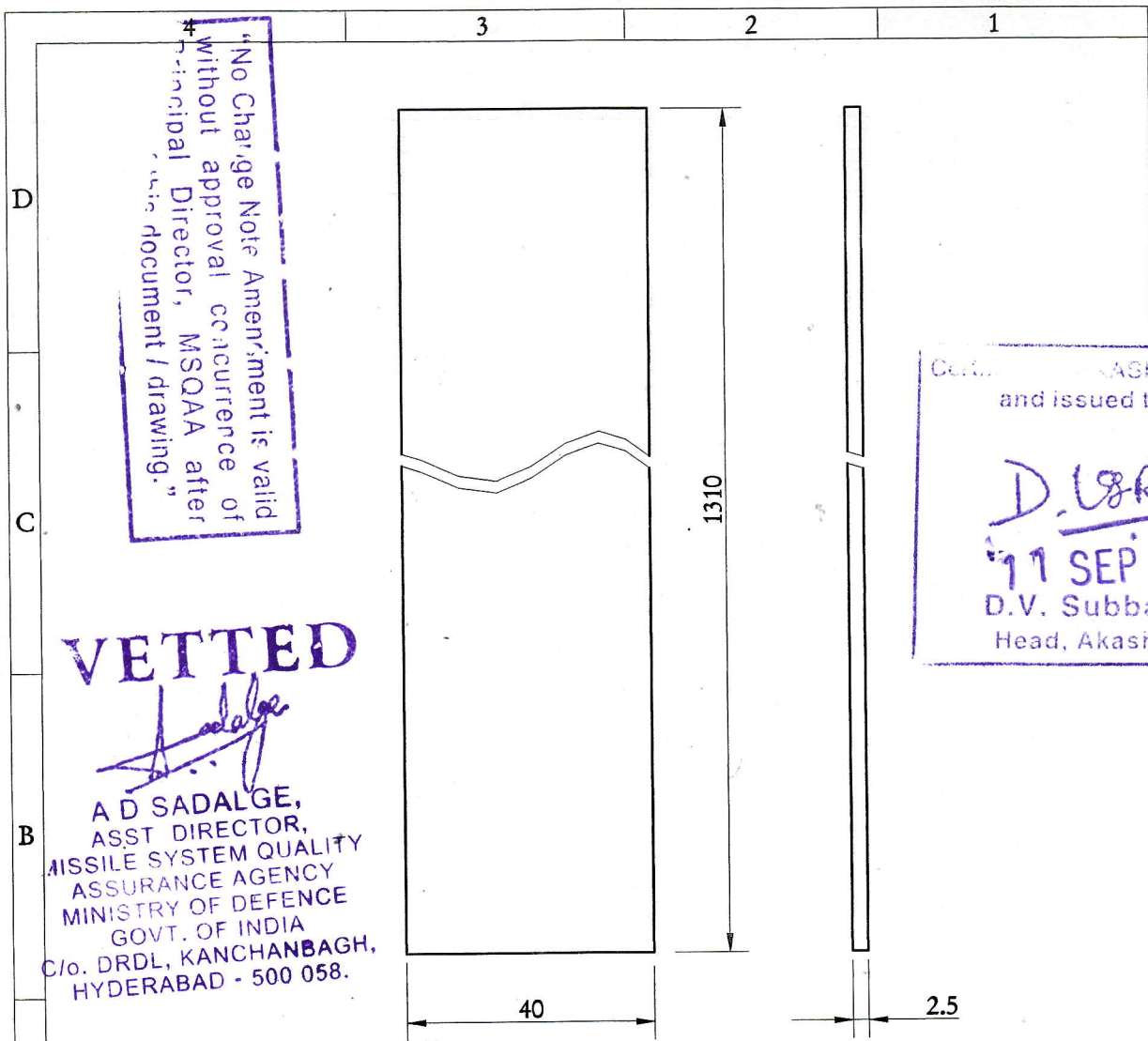

No Change Note Amendment is valid without approval concurrence of Principal Director, MSQAA after this document / drawing.

Curd... ASH Production and issued to BDL
D. V. Subba Rao
 11 SEP 2014
 D.V. Subba Rao
 Head, Akash-TTG

VETTED

A. D. Sadalge
A D SADALGE,
 ASST DIRECTOR,
 MISSILE SYSTEM QUALITY
 ASSURANCE AGENCY
 MINISTRY OF DEFENCE
 GOVT. OF INDIA
 C/o. DRDL, KANCHANBAGH,
 HYDERABAD - 500 058.

NOTE: Velcro is stitched to the cotton reinforcement belt such that minimum circular overlapping should be 100mm.

REVISION	R.No.	DATE	AUTHORITY	ZONE	BRIEF RECORD	INITIALS
1	1	06-06-13	S&SRPD		1. Dim 40 was 30	<i>AS.</i>

DEVIATION FOR UNTOLERANCED DIMENSIONS TO CONFORM TO SPEC. IS : 2102, MEDIUM (PART 1 & 2) : 1993		DRAWN TO SPEC. IS : 10714-1983(R 1999) IS : 10714 (PART 20) : 2001 & IS : 10714 (PART 21) : 2001 AND DRDL NOTE SHT. 1 & 2	
SCALE: 1:1 DIMENSIONS ARE IN mm.		MATL.: COTTON BELT	
DRN	21-10-11	G.S.RAJU	FINISH:
MASS : 0.105 kg		<i>G. Satyanarayana</i> TECH. OFFICER	
BELT REINFORCEMENT		<i>R. Satyanarayana</i> APPD (DRG)	
Defence Research & Development Laboratory HYDERABAD		ASSY DRG No. RPD/AK/CA/01 03 03 00	
		DRG. No. RPD/AK/CA/01 03 03 04	