

DRAWING NUMBER
301-20-3

SHEET No. 1 OF 1

10 / (✓)

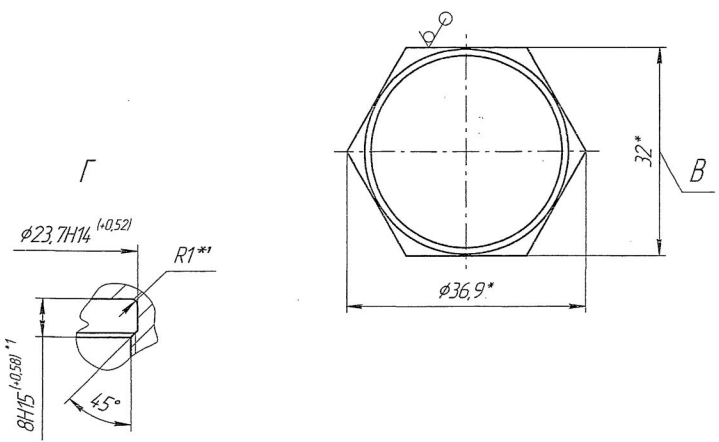
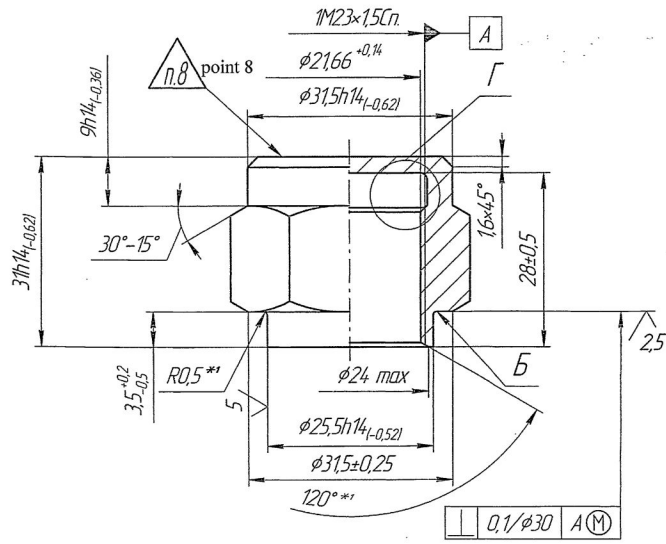

1. Alternate material: Hexahedron 32-h-11 GOST 8560-78
45X-B GOST 1051-73

- It is permitted to remove the surface defects by rolling with glorification of dimension B up to 32h13 (-0.39).
2. Inspection group III as per TT-11.
 3. 28 ... 32 HRC.
 4. Plating Cadmium chrome plating having thickness 9 microns as per ИЛ-569-84, removal of hydrogen embrittlement. Absence of plating in groove Γ is permitted.
 5. Deviation from planeness of surface B is checked "by paint". Adjoining should be on ring with width not less than 2 mm.
 6. Technical requirements for thread as per standard 82021-00.
 7. Check the part on magnetic flaw detector. Carry out acceptance according to TT ИВ-17.
 8. Stamp by electric spark method or chemical method.
 9. * Dimensions for references.
 10. *1 Dimensions are ensured by tool.

(A) EQUIVALENT MATERIAL STEEL 709M40
(EN19) BS970/40Cr4Mo3 IS:1570

PILOT SAMPLE SHOULD BE APPROVED BY A H S P BEFORE BULK PRODUCTION.

EST. WT. (Kg) 0.1	TO BE STAMPED OR MARKED WHERE INDICATED THUS # (LETTERS)
ALL SHARP EDGES AND CORNERS TO BE REMOVED UNLESS OTHERWISE STATED MACHINED CORNERS TO HAVE R OUTSIDE R INSIDE EQUIVALENT CHAMFERS ARE PERMISSIBLE.	

DRN	1. 08/01	MATERIAL - Hexahedron	USED ON:-
CHD	Oversee Dept	32-h11 GOST 8560-78	Cb.3301-00-37
APPD	R. S. S. S. S.	45X-B GOST 1051-73	Cb 3301-00-44 (B)
DATE	5.12.08	CONTROLLERATE OF QUALITY ASSURANCE (HEAVY VEHICLES)	
SCALE:	2:1	AVADI	
DIMENSIONS IN mm	TOLERANCE ON DIMNS UNLESS OTHERWISE STATED IS: 2162-69		
B	16.12.13	Authy: Lt. No. 111908/CQA(HV)/DB/ENG/1-90/AMDT Dt: 24.12.2013	TITLE:- NUT
A	13.8.10	4 th Alt. Comm. Meeting Minutes Point No.11 Dt: 26-10-09	
ISSUE	DATE	NATURE OF AMENDMENTS	D S CAT NUMBER
			DRAWING NUMBER 301-20-3

DRAWING INDIANISED BASED ON RUSSIAN ORIGINAL ISSUE - NIL

F-158
SIZE A2

