

SCAN

601700-09ES
D.S. CAT. NO. 5360-007109

DRAWING CONVENTIONS CONFORM TO JSG-0104
DIMNS. ARE IN mm.

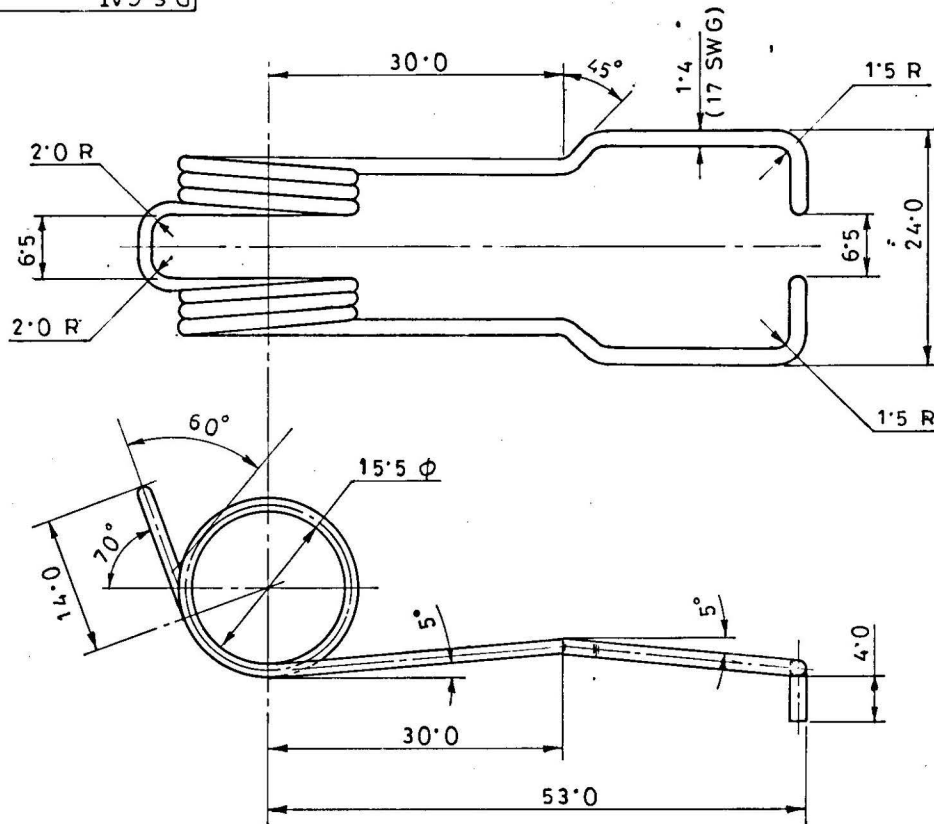

MARKING ON TAG.

Yr. OF Mfg.
MANUFACTURER'S CODE,
D.S. CAT. NO.

TOLERANCE FOR UNTOLERANCED DIMNS. ± 0.2

TOLERANCE FOR ANGLES $\pm 1^\circ$

WIRE DIA. ———— 1.4

NO. OF EFFT. COILS — 3+3

WOUND ———— AS SHOWN

LOAD TO BE ENSURED AS FOLLOWS:-

DEFLECTION 60° --- 3.5 Kg $\pm 5\%$

DEFLECTION 135° --- 7.9 Kg $\pm 5\%$

STRESS RELIEVED.

09.09.16	26937-3A	MATERIAL AMENDED.		RKSann					
21.06.13	26675-5A	LOAD VALUE AMENDED IN ZONE C-7		RKSann					
13-7-10	26522-5A	NSN ADDED		RKSann					
18-2-08	26400-3A	ALTERNATIVE MATERIAL ADDED.							
18-5-07	26338-2A	MATERIAL AMENDED							
10-2-98	24045-5A	PROFORMA CHANGED, MARKING NOTE ADDED, NEG. RE-TRACED AND DRG. PROV. RE-SEALED. PREVIOUS D.C. NO. 23755- SA.							
DATE	AUTHY.	BRIEF RECORD	ZONE	I/C, D.O.	G. O.	MATERIAL :-	IS: 4454 PT 1: 2001, Gr. DH WITH UTS VALUE MIN 2290N/mm ²	DGNR'S REF.	ARDE SK.2689/131
SEALED :- PROV. D.C. NO. 23755-SA, DT. 20. 3.97				SIGN.		H.T./HARDNESS:-		PART NO.	
NOMENCLATURE:- SPRING, HELICAL TORSION FOR HAMMER						PROTECTIVE PHOSPHATE TO SPECN. JSS-0465-01: FINISH 1988 CLASS II(ACCELERATED) OIL FINISH		D.S. CAT. NO. 5360-007109	

NSN: E1/5360-72-0001109

AHSP CQA(SA), ICHAPUR

ASSY. 1005-007867

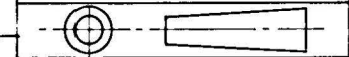

DGNR'S REF. ARDE SK.2689/131

PART NO.

DRG. NO.

D.S. CAT. NO. 5360-007109