

DRG No. 02040304000600500DA
 IC SS C AA V C ISS
 02040304000600500DA

GENERAL TOL. : FINE / MEDIUM / COARSE CLASS TO IS: 2102
 DRG. CONVENTIONS CONFIRM TO INDIAN STANDARDS DIMENSIONS ARE IN mm UNLESS OTHERWISE STATED.

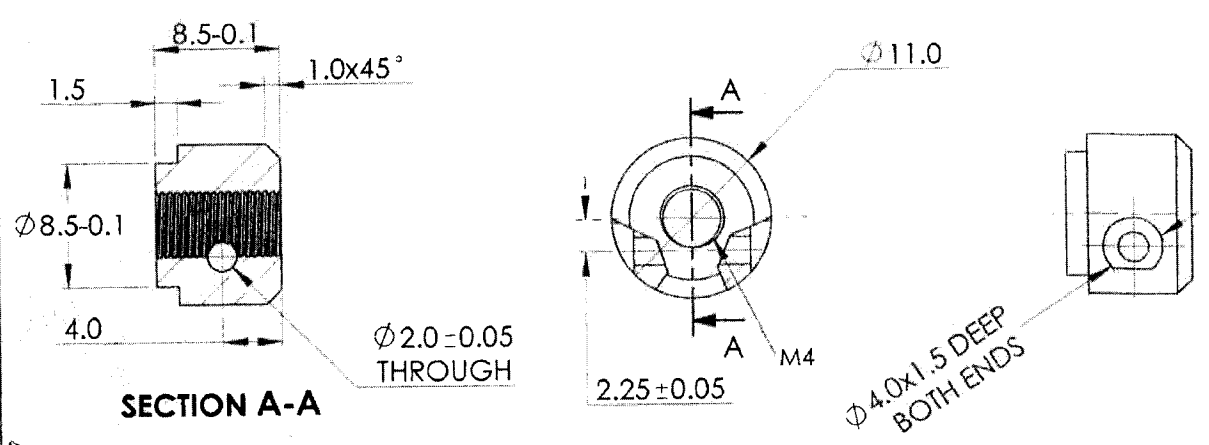

CONTROLLED COPY No.: 03

- NOTES:-
- 1) REMOVE ALL SHARP EDGES AND BURRS.
 - 2) HARDNESS:- 260 TO 310 H.V.
 - 3) SURFACE FINISH $\nabla\nabla$ ALL OVER EXCEPT WHERE SPECIFIED.
 - 4) IF COMPONENT TO BE MANUFACTURED THROUGH MIM ROUTE REFER ARDE SPECN. No. DRDO/ARDE/MIM/TSP/051/2019.
 - 5) ALT. PROTECTIVE COATING: PHOSPHATED TO SPECN. IS: 3618-1966, CLASS 'B'

Sr. No.	DATE	AUTHORITY	BRIEF RECORD	ZONE	CD SIGN	GO SIGN

DRN: SOURABH
 SIGN: *Sourabh*
 DATE: 07/03/2019 CHECKED

MATERIAL:
 STEEL TO IS: 5517 - 1993, Gd 55C8

PROTECTIVE FINISH:
 ELCTROLESS NICKEL-BORON NITRIDE (NiBN) COATING AS PER ARDE SPECN. No. ARDE/SA/2016/COATING-02

APPD.
 DATE: 07/03/2019 FOR DIRECTOR

SEALED DATE:

SHEET SIZE: A4
 SCALE: 2:1

EST. MASS
 4.5 gm

TITLE:
STOPPER REAR SPRING RECOIL

DESIGN AUTHORITY
ARDE
 PUNE 411021

DRG No. 02040304000600500DA
 IC SS S AA A C SST

JVPC PART No. DSCAT No. AHSP

Handwritten notes:
 Holes 1mm
 2mm

Handwritten mark: