

DRAWING No.
EFA/DDO/SK-1432

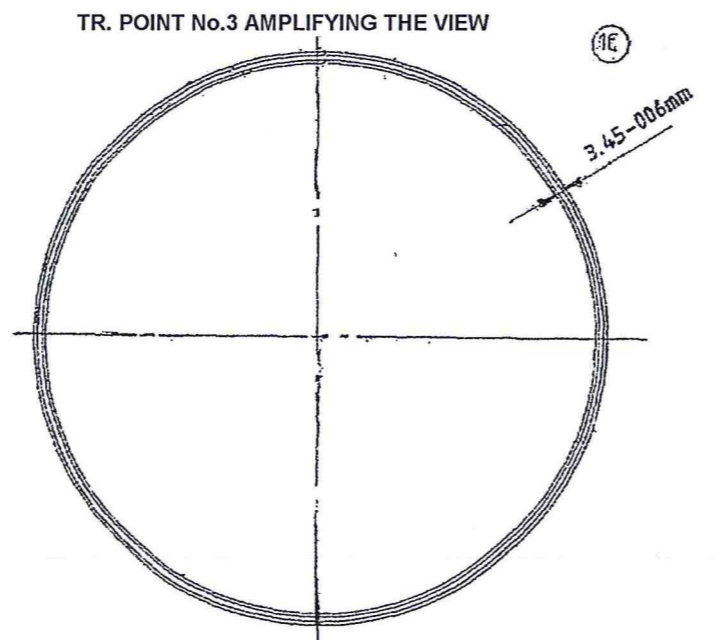
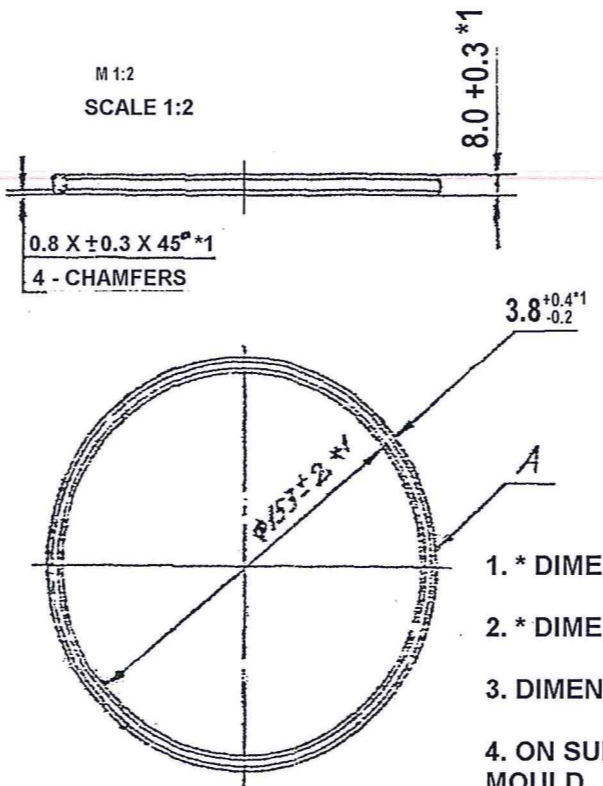
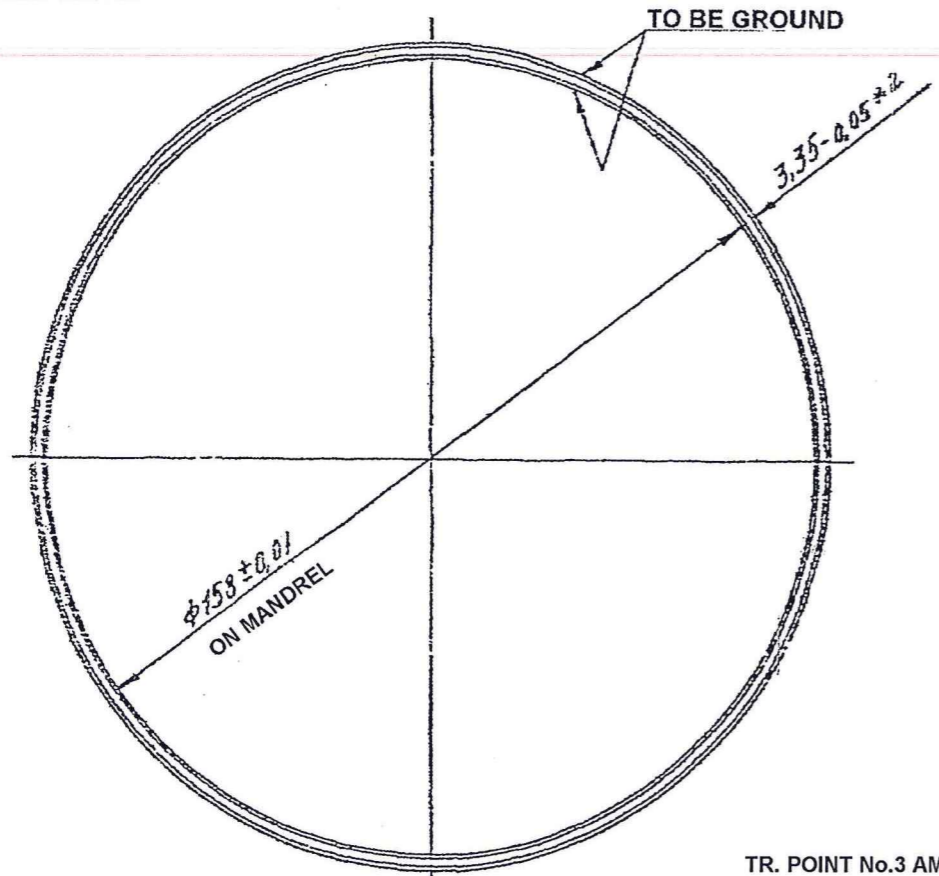
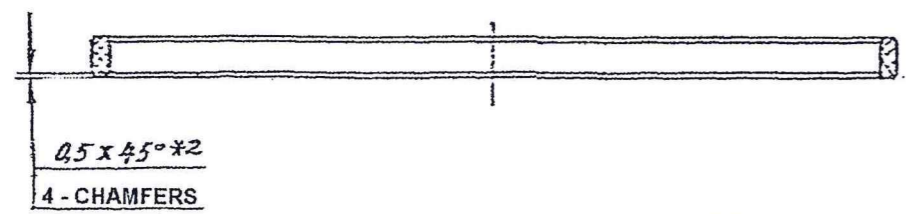

EXPLANATORY NOTE :-

10. MATERIAL QUOTED : RUBBER ИРП - 1287 ТУ 005216-75.
ИРП - 1287 - RUBBER GRADE
- a) MECHANICAL PROPERTIES :-
- RUPTURE STRENGTH = 120 Kgf/cm² (min)
 - ELONGATION OF RUPTURE = 120 % (min)
 - RESIDUAL ELONGATION AFTER RUPTURE = 10 % (max)
 - HARDNESS ACCORDING TMP DEVICE (TM-2) = 70 - 82 ARBITRARY UNIT. %
 - DENSITY (DEVIATION LIMIT ± 0.05) = 2.10 g/cm³

1. * DIMENSIONS ARE TO BE ENSURED WITH TOOL.
2. * DIMENSIONS ARE FOR REFERENCE.
3. DIMENSION OF RING WIDTH IN FREE CONDITION IS 3.45 - 0,06mm. AFTER GRINDING
4. ON SURFACE "A" PROJECTIONS UP TO 1.0mm ARE ALLOWED DUE TO DENTS OF THE MOULD.
5. TO BE MARKED ON TAG.
6. FOR TROPICALIZED CONSTRUCTION - ТИ п. 150 GOST 15152-69.
7. THE REST OF REQUIREMENTS AS PER TY 005216-75
8. ALT. MATL.: RUBBER GRADE FKM TO SPECN CQA(HV)/FKM
9. DIMENSIONS ARE IN mm

MATERIAL : - RUBBER ИРП - 1287 , TY 005 216-75

PILOT SAMPLE SHOULD BE APPROVED BY A-H S P BEFORE BULK PRODUCTION.

EST. WT. 0.029 Kg	TO BE STAMPED OR MARKED WHERE INDICATED THUS # LETTERS)
----------------------	---

ALL SHARP EDGES AND CORNERS TO BE REMOVED UNLESS OTHERWISE STATED MACHINED CORNERS TO HAVE R OUT-SIDE R INSIDE EQUIVALENT CHAMFERS ARE PERMISSIBLE.

MATERIAL :- RUBBER ИРП - 1287 ТУ 005 216-75.	USED ON :- 303-00-23 303-01-23
--	--------------------------------------

ENGINE FACTORY AVADI

TITLE LINER RING (FOR V92S2 ENGINE)
--

DRAWING No. EFA/DDO/SK-1432
