

82-71-28

UNLESS OTHERWISE SPECIFIED.

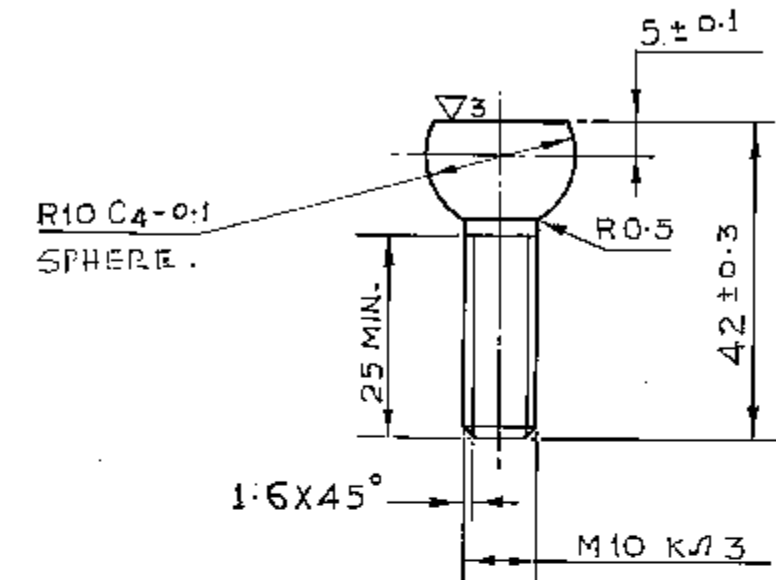

TECHNICAL CONDITIONS.

1. ALTERNATE MATERIAL IS 40 GOST 1050-60
 2. HEAT TREATMENT HB 205 TO 229. (03-6 TO 4-0)
 3. COATING-9 MICRONS THICK ZINC PLATED, CHROMIUM PLATED.
- CHECK THE DIMENSIONS BEFORE COATING REMOVE HYDROGEN EMBRITTLEMENT.

NOTE:

1. ALL DIMENSIONS ARE IN MM.
2. THE ABBREVIATIONS AND SYMBOLS ARE BASED ON RUSSIAN SPECIFICATIONS.

NEAREST EQVT MATERIAL			
45 GOST 1050-60			
ORGL MATERIAL	DCGN#	ISSUE	AMENDMENTS
	A DATE		
ALL SHARP EDGES & CORNERS TO BE ROUNDED OFF.	ALL THREADS TO CONFORM TO SPECIFICATION.	STAMP OR ETCH, PART NO. MANUFACTURER'S NAME & YEAR OF MFR.	
DRG. NOT TO BE SCALED			
SCALE:- 1:1	TOLERANCE ON DIMENSIONS UNLESS OTHERWISE SPECIFIED	USED ON:-	
DATE :- 24-12-93		773-82-c8 106	
DRN. <i>Alh</i>	WT:-(Kg)	BOLT	
TCD. <i>Alh</i>	0.04		
CHD. <i>Alh</i>	DRAWING NO 765-71-28	PART NO	
APD. <i>Alh</i>			
CONTROLLERATE OF QUALITY ASSURANCE (INFANTRY COMBAT VEHICLES)			