

DRG. NO: FS- 3226

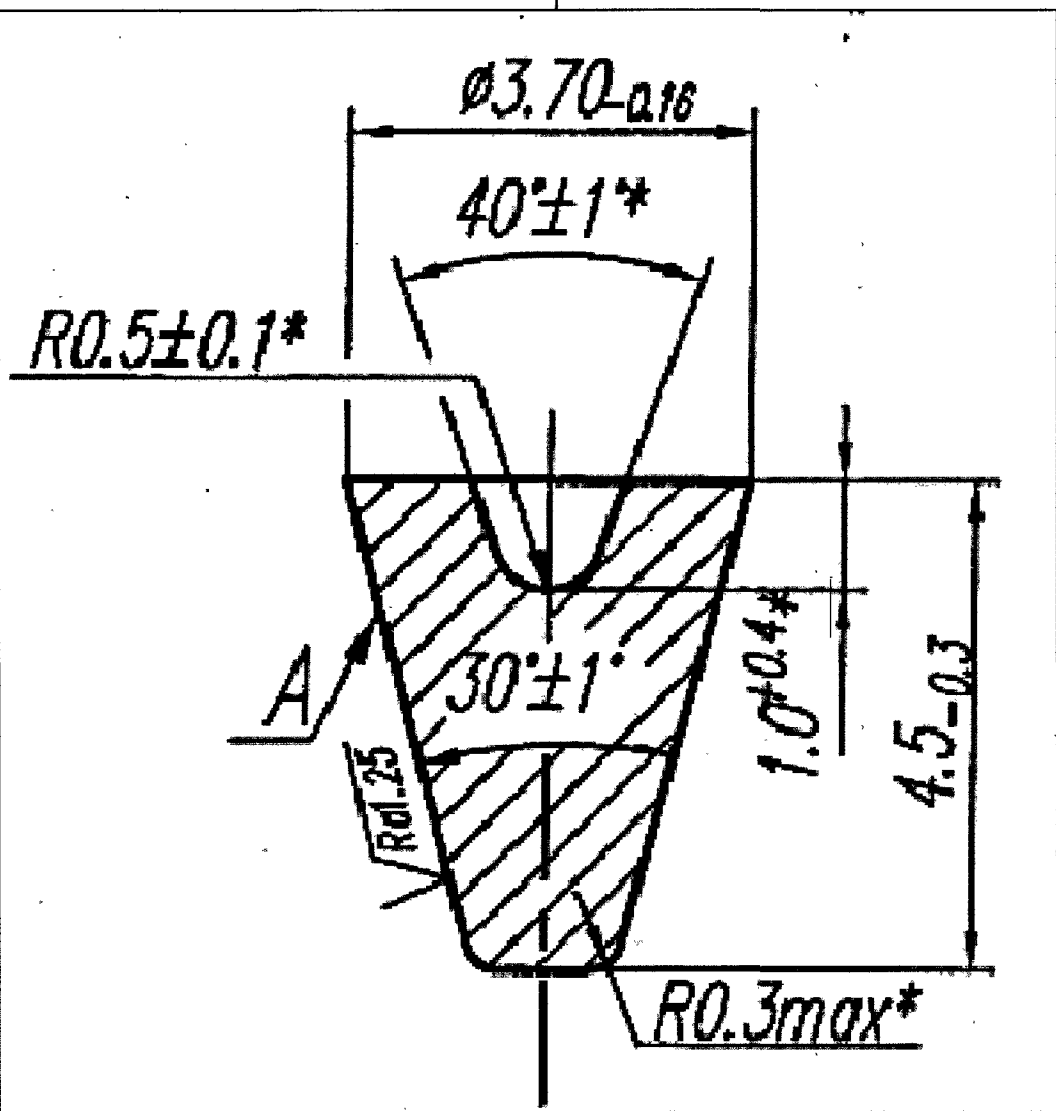

1 Anneal in closed metal boxes covered with cast iron filings or in the neutral environment at the temperature of 700 to 720 °C for 60 to 80 min with subsequent cooling in water.  
 2\* Dimensions provided by measuring instruments.  
 3 Coating Chem. Pass / varnish BП-7-2.  
 4 Coaxiality tolerance of an impression relative to surface A shall match the design of the corresponding part.  
 5 The following is allowed:  
 a) wire ДКРХТ 4,0 МД М06 GOST 4752-2012;  
 b) varnish BП-7-3 and varnish ПШ-3 or ПШ-5. OST 84 811-2002;  
 c) wire ДКРХТ 3,0 МД М06 GOST 4752-2012.  
 6 The part shall have no cracks, scabs, cavities, holes, deep pot holes, scratches, unevenness.

7 Characteristics of special-purpose phenol-polyvinylacetyl varnishes:  
 Special-purpose phenol-polyvinylacetyl varnishes are solution of glue БФ-4 in ethyl alcohol. The varnish is a transparent slightly cloudy homogeneous liquid of a light yellow to dark yellow color without mechanical impurities.  
 Varnishes BП-7-2, BП-7-3, where: BП - varnish designation by chemical composition (phenol-polyvinylacetyl varnish);  
 7 - varnish group of purpose;  
 2, 3 - weight ratio of dry phenol-polyvinylacetyl residue.  
 Varnishes BП-7-2, BП-7-3 is intended for parts and articles varnishing.  
 Operating temperature of varnish coatings: from minus 60 to plus 80 °C - unlimited in time; at plus 150 °C - for 5 hours.  
 Phenol-polyvinylacetyl varnishes are a flammable, non-explosive material. Ethyl alcohol is inflammable liquid: maximum allowable concentration (MAC (ПДК)) in production floor area working air - 1000 mg/m<sup>3</sup>; flash-point - plus 13 °C.  
 The shelf life of the varnish is 6 months after the manufacture date.

ALT. MAT:-

IS:12444-1988 (RA-2015) OR IS:6912-1985  
 ETP 'O' CONDITION.

(REF. NO. CQA(M)/QA-2/T-72/FSAPDS/MANGO/  
 VOL. 12. DATED. 29.07.2021).  
 SHELLAC BASED ADC TO SPECIFICATION  
 JSS 8010-63:2016 (REV. No.4)  
 (REF. NO. CQA(ME)/T200/GEN(PC)/125 mm  
 FSAPDS (AMK 339)/02 Dt. 05.04.2021

√Rz20(√)

REV.		DATE	DESCRIPTION	SIGN.	DIMENSIONS ARE IN mm		MATERIAL: M1 GOST 859-2001		आईनैन्स फैक्टरी अम्बाझरी			
AMENDMENTS					THIRD ANGLE PROJECTION		NOMENCLATURE: OBTURATING CONE		ORDNANCE FACTORY AMBAJHARI			
					SCALE - 1:1		DRG. NO: FS- 3226		REVIEW NO: 0			
					2021	NAME	DATE	SHEET NO: 1		NO. OF SHEETS: 1		
					DRAWN	Rush	16/8/21	OPERATION NO:		COMPT:		
					CHECKED	[Signature]	16/8/21	M/C:		STORE:		
					HOS/CDD							
					VERIFIED BY	JWM/FS	[Signature]	17/8/21				
					APPROVED BY	DGM/FS	[Signature]					