

8

7

6

5

4

3

2

1

THIS DOCUMENT AND THE INFORMATION CONTAINED IN IT ARE PROPRIETARY AND CONFIDENTIAL TO OFT. NO PERSON OR ENTITY IS ALLOWED TO COPY, REPRINT, REPRODUCE OR PUBLISH ANY PART OF THIS DOCUMENT, NOR DISCLOSE ITS CONTENTS TO OTHERS, NOR MAKE ANY USE OF IT, NOR ALLOW OR ASSIST OTHERS TO MAKE ANY USE OF IT UNLESS BY THE PRIOR WRITTEN EXPRESS AUTHORIZATION OF OFT AND THEN ONLY TO THE EXTENT AUTHORIZED. COPYRIGHT-OFT.

SHEET REV STATUS  
ALL SHEETS ARE THE SAME REVISION

REV		ECO	DESCRIPTION	DATE	APVD
01			Issue	18-Aug-17	O. Sarman
02			Revised	08-Apr-18	L. Gokulatharan
03			Revised	28-Jun-18	S. Ramani

NOTES:

1. INTERPRET THIS DRAWING IAW ASME Y14.100M.
2. MATERIAL: SEE FN 1.  
(BASE MATERIAL: ALUMINIUM ALLOY SAND CASTING A357.0 T6 PER AMS-A-21180 CL12).
3. DEBURR AND REMOVE SHARP EDGES APPROX. 0.3X45°.
4. GENERAL TOLERANCES ACCORDING TO ISO 2768-m.
5. QUALITY ASSURANCE PROVISIONS:  
5.1 QUALITY ASSURANCE PROVISIONS FOR THIS ITEM PER RDMQD00012P.  
5.2 MAJOR CHARACTERISTICS NRS 101 TO 112.
6. PARENTHEetical FIGURES ARE FOR REFERENCE ONLY.
7. PACKAGING AND PACKING:  
THE FINISHED PART SHALL BE PRESERVED AND PACKAGED IN ACCORDANCE WITH COMMERCIAL PRACTICE.
8. IDENTIFY PER MIL-STD-130 PARA 4.1.B, BY LABELING ITS CONTAINER WITH THE PART NUMBER, CHARACTERS 1.5 MM MIN. HIGH.

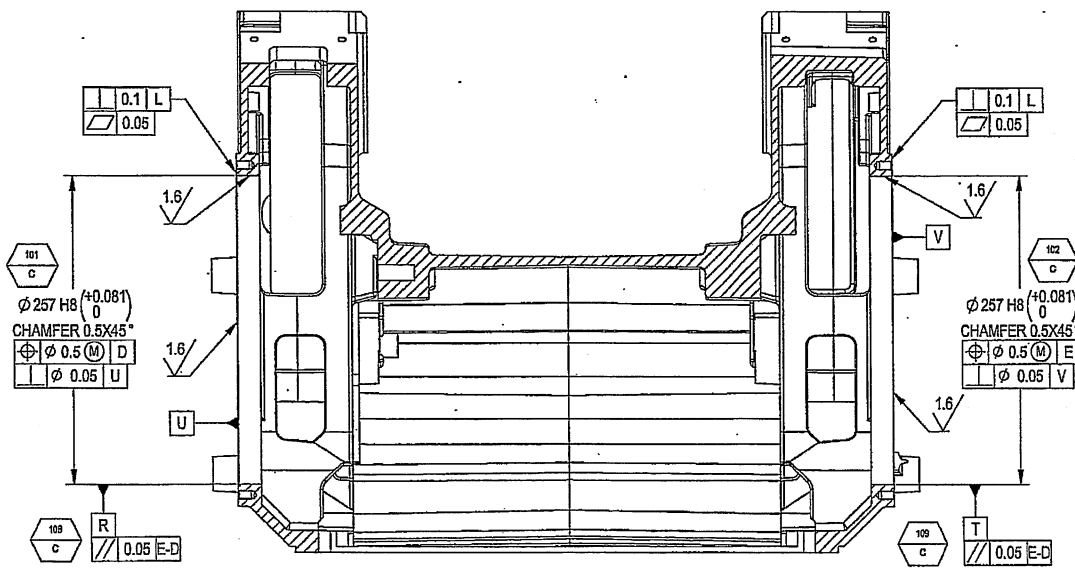
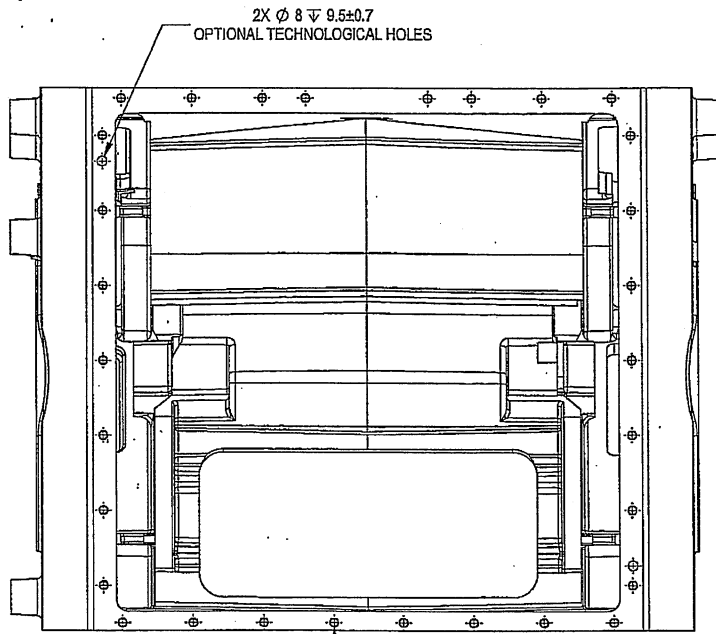

30 X M6X1.0  
FOR HELICAL COIL INSERT  
DRILL  $\sqrt{13}$  MAX. FLAT BOTTOM  
THD PER MA1567 X 1.5D  
 $\varnothing 0.4$  F M L

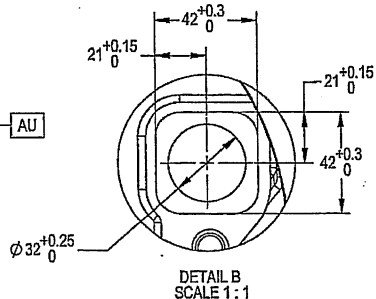
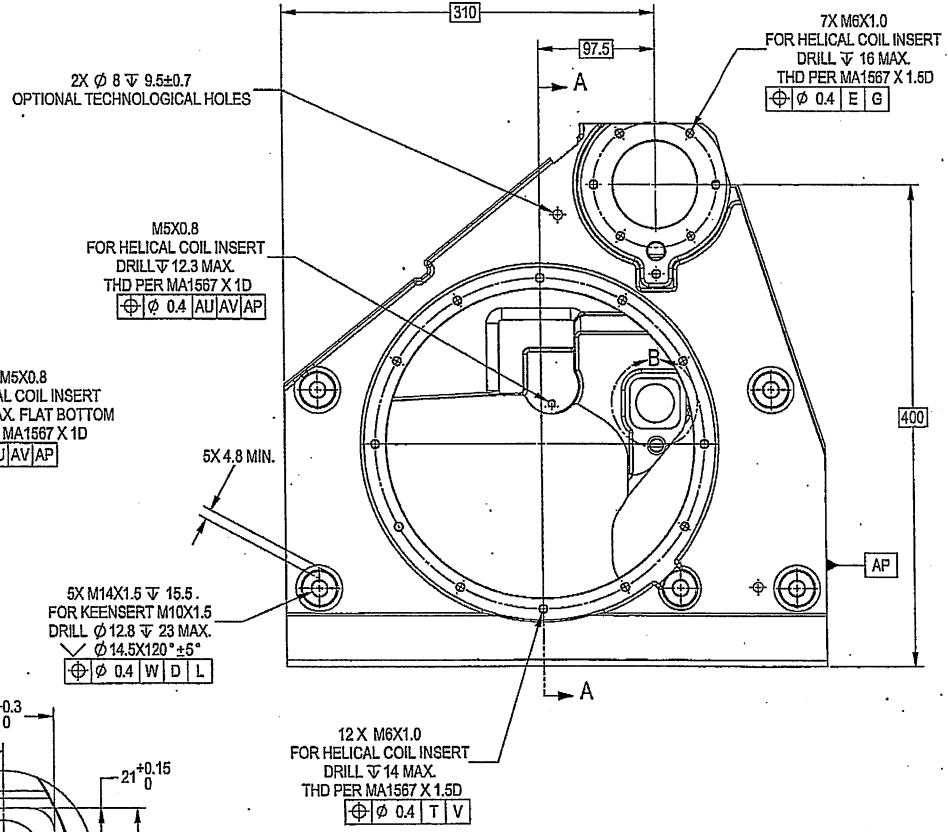
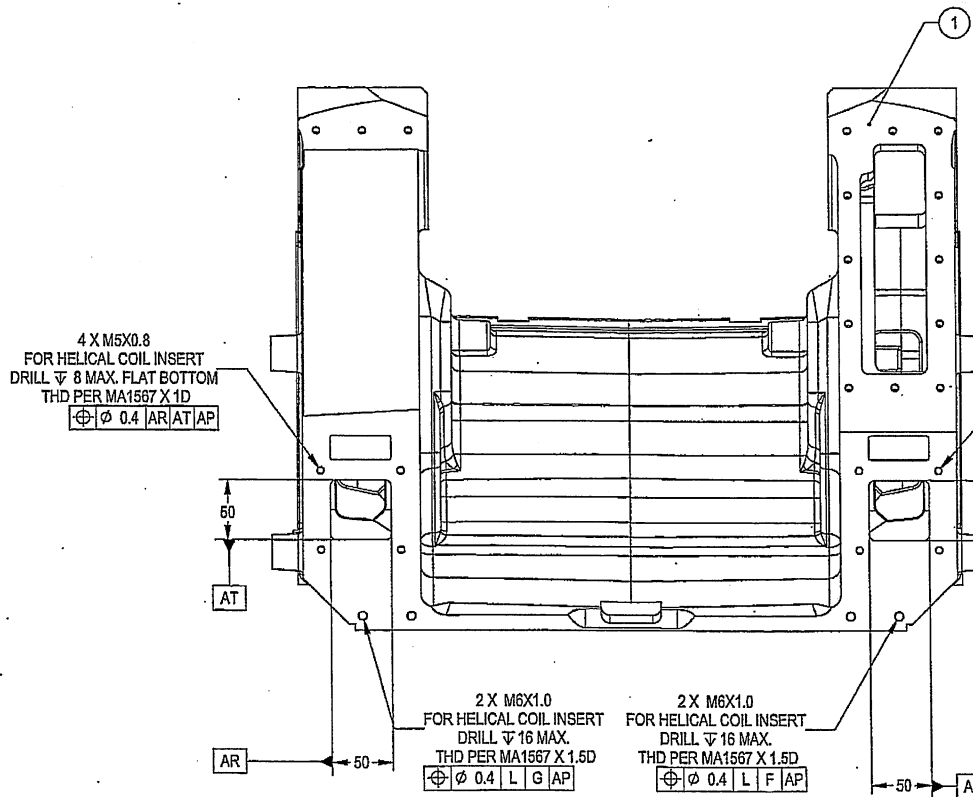

(WEIGHT APPROX.: 25.31 Kg.)

3.2 / 0.8 / 1.6

UNLESS OTHERWISE SPECIFIED		SIGNATURE		DATE		ORDNANCE FACTORY	
DIMENSIONS ARE IN MM PER ASME Y14.5 - 2009		DRAWN		DATE		TRICHURAPPALLI	
TOLERANCES		CHECKED		TITLE		FOR: CASING MAIN FINISHED	
LINEAR	ANGULAR	HOSDDO		OF: 12.7MM SRCG			
1:1 ANGLE PROJECTION	OFFICER/PRODN	OFFICER/PRODN		OFFICER/PRODN			
	OFFICER/DOC	OFFICER/DOC		OFFICER/DOC			
	OFFICER/QAD	OFFICER/QAD		OFFICER/QAD			
		SCALE 12		AUTOMATED DRAWING (SW)		SHEET 1 OF 4	

PROJECT OFFICER

PLJ Contd

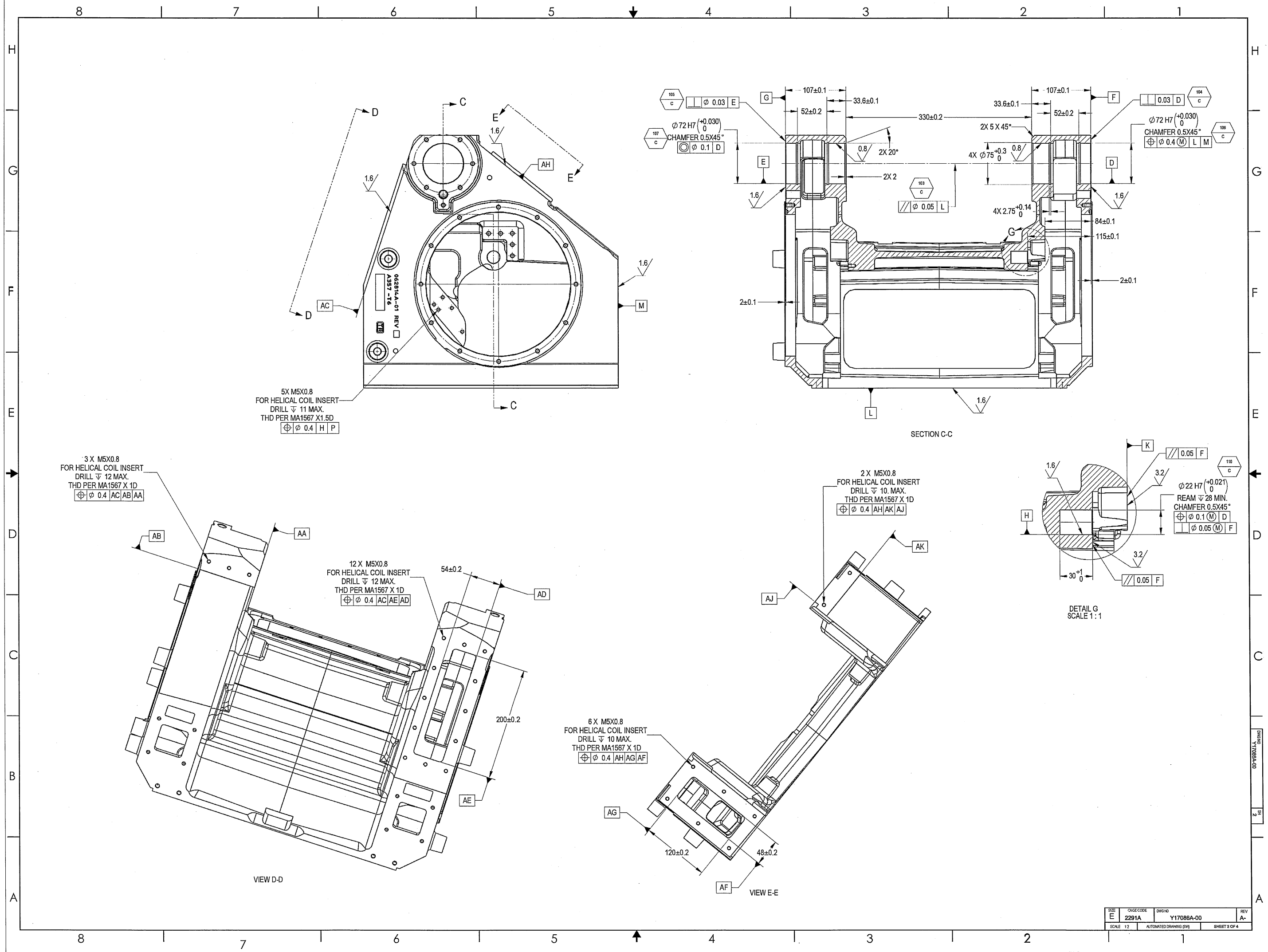

SIZE	E	DWG CODE	2291A	DWG NO	Y17086A-00	REV	A-
SCALE	1:2	AUTOMATED DRAWING (DWG)		SHEET 2 OF 4			



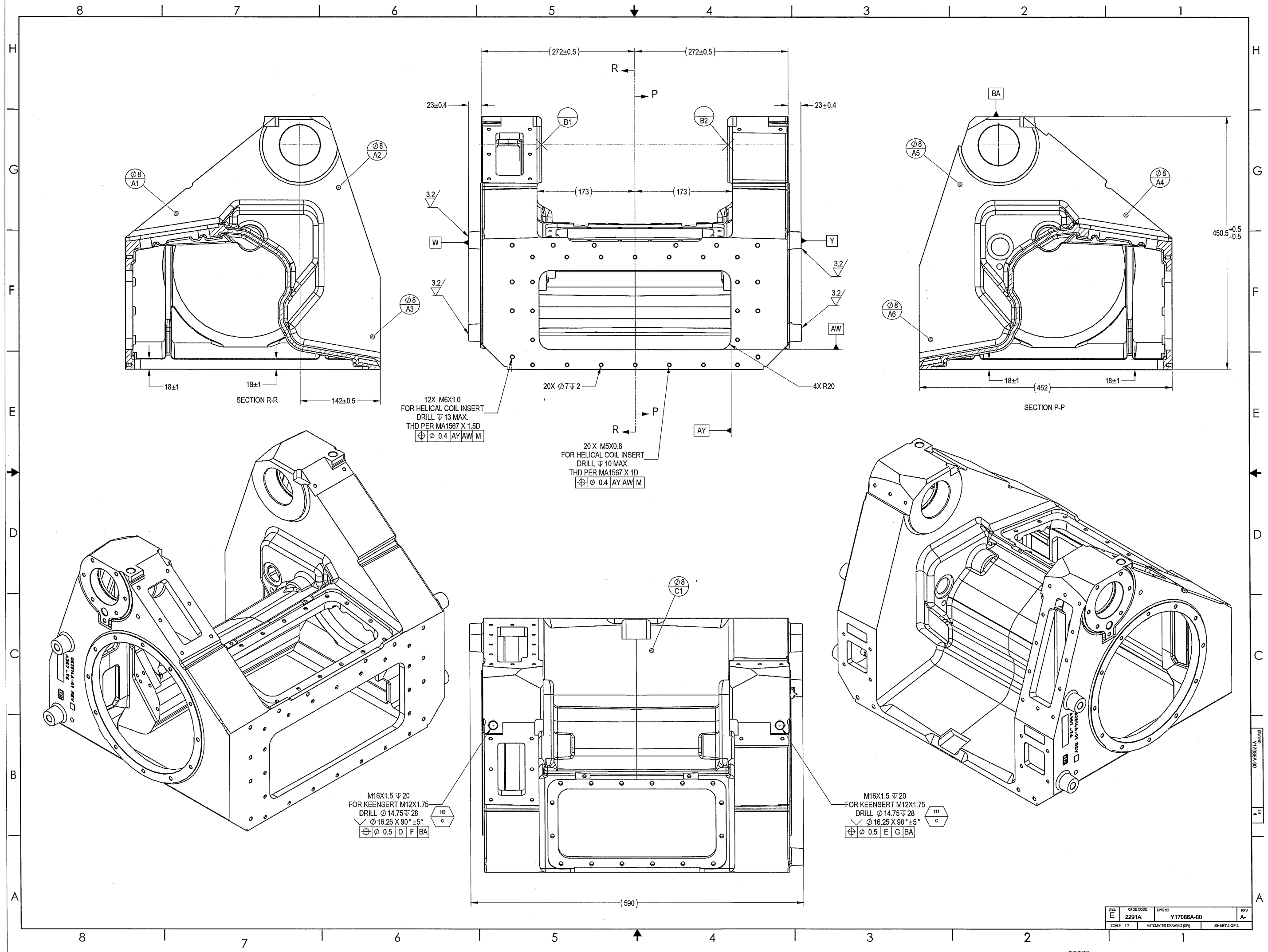

SIZE	SCALE	DWG NO	REV
E	1:1	Y17086A-00	A-
2291A		Y17086A-00	
SCALE	1:1	ALTERNATE DRAWING (SW)	SHEET 4 OF 4

PLM Control

OFT

ASSEMBLY PARTS LIST

Assembly Parts List For: Y17086A-00

Rev: A-

Status: Released

Description: CASING, MAIN

FN	CMD	PART NUM	ECO	DESCRIPTION	MB	QTY	U/M	REF. DES./REMARKS	MFG. PN / CUSTOMER	LA	LI
1	CS	062814A-01		CASING CASTING, MAIN	P	1	Each				