

M-1700

ITEM NO.	PART NUMBER	DESCRIPTION	QTY.
1	M-1801 PAWL, BELT HOLDING, LEFT HAND (7313081)	PAWL, BELT HOLDING, LEFT HAND, 00W50BMG	1
2	M-1802 PAWL, BELT HOLDING, RIGHT HAND (7313082)	PAWL, BELT HOLDING, RIGHT HAND, 00W50BMG	1
3	M-1803 SLEEVE, BELT HOLDING PAWM (7160627)	SLEEVE, BELT HOLDING PAWL, 00W50BMG	1

REVISIONS				
ZONE	REV.	DESCRIPTION	DATE	APPROVED
	A	CREATE DRAWING	8/10/2015	G. HERSHBERGER

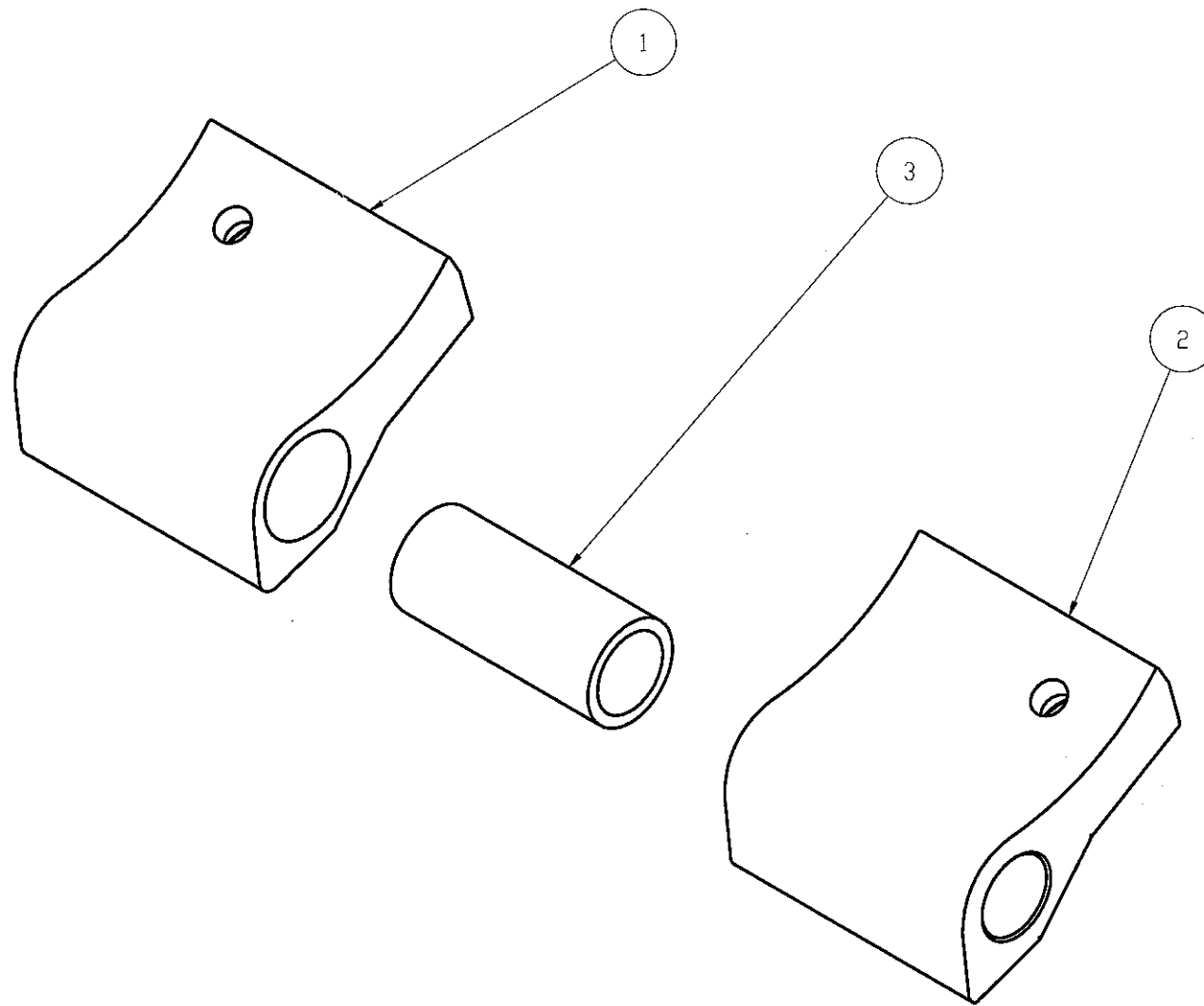

अस्थायी रूप से प्रमाणित
Provisionally Approved

24 AUG 2021

रिजिस्टर
एस्टाब्लिशमेंट
For Code (API)

ITAR CONTROLLED THIS DOCUMENT IS CONTROLLED UNDER THE ITAR. IT MAY NOT BE PROVIDED TO A NON-US RESIDENT WITHOUT THE WRITTEN APPROVAL OF THE U.S. GOV'T. VIOLATIONS WILL RESULT IN CIVIL OR CRIMINAL PENALTIES. PROPRIETARY AND CONFIDENTIAL THE INFORMATION CONTAINED IN THIS DRAWING IS THE SOLE PROPERTY OF OHIO ORDNANCE WORKS, INC. ANY REPRODUCTION IN PART OR AS A WHOLE WITHOUT THE WRITTEN PERMISSION OF OHIO ORDNANCE WORKS, INC. IS PROHIBITED.	UNLESS OTHERWISE SPECIFIED	NAME	DATE	OHIO ORDNANCE WORKS, INC. PAWL ASSEMBLY, BELT HOLDING, 00W50BMG SIZE C 7313083 REV A SCALE: 4:1 WEIGHT: SHEET 1 OF 2	
	DIMENSIONS ARE IN MM/INCHES/ ALL THREAD DIM ARE IN INCHES	DRAWN	PHD		08/10/15
	TOLERANCES: FRACTIONAL ANGULAR MACH ± BEND TWO PLACE DECIMAL ±0.25 THREE PLACE DECIMAL ±0.127	CHECKED			
	INTERPRET GEOMETRIC TOLERANCING PER MATERIAL	ENG APPR.			
	FINISH	NFG APPR.			
	DO NOT SCALE DRAWING	QA			
		COMMENTS:			

REVISIONS				
ZONE	REV.	DESCRIPTION	DATE	APPROVED
-	-	See Sheet 1	-	-

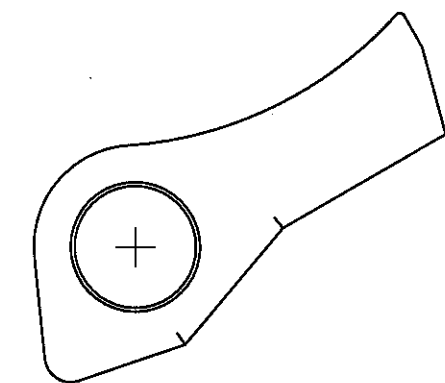
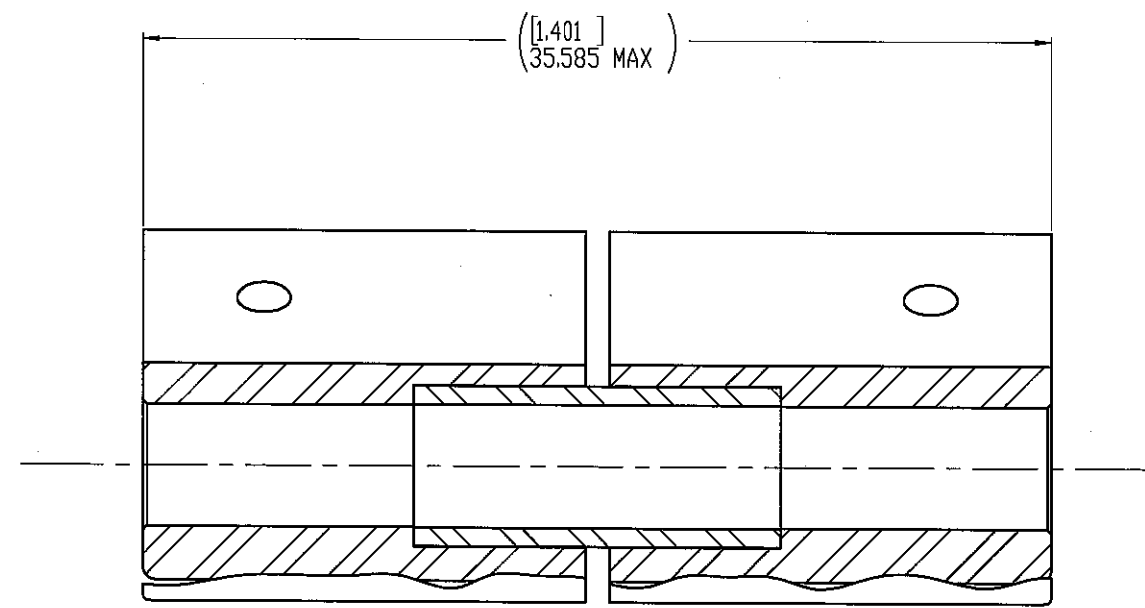

प्रमाणित
 Provisionally Approved
 24 AUG 2021
 हस्ताक्षर/Sig
 For Grade (A1)

ITAR CONTROLLED THIS DOCUMENT IS CONTROLLED UNDER THE ITAR IT MAY NOT BE PROVIDED TO A NON-US RESIDENT WITHOUT THE WRITTEN APPROVAL OF THE US GOVT. VIOLATIONS WILL RESULT IN CIVIL OR CRIMINAL PENALTIES. PROPRIETARY AND CONFIDENTIAL THE INFORMATION CONTAINED IN THIS DRAWING IS THE SOLE PROPERTY OF OHIO ORDNANCE WORKS, INC. ANY REPRODUCTION IN PART OR AS A WHOLE WITHOUT THE WRITTEN PERMISSION OF OHIO ORDNANCE WORKS, INC. IS PROHIBITED.	UNLESS OTHERWISE SPECIFIED DIMENSIONS ARE IN MM/INCHES ALL THREAD DIM. ARE IN INCHES TOLERANCES:	NAME	DATE	OHIO ORDNANCE WORKS, INC. PAWL ASSEMBLY, BELT HOLDING, 00W50BMG	
	FRACTIONAL	DRAWN	PHD 08/10/15		
	ANGULAR: HATCH ± BEND TWO PLACE DECIMAL ±0.25 THREE PLACE DECIMAL ±0.127	CHECKED			
	INTERPRET GEOMETRIC TOLERANCING PER:	ENG APPR.			
MATERIAL	MFG APPR.			SIZE C 7313083	
FINISH	D.A.			REV A	
DO NOT SCALE DRAWING	COMMENTS:			SCALE: 4:1 WEIGHT: SHEET 2 OF 2	

M 1703

NOTES:

1. FINISH $\sqrt{3.2}$ ALL OVER.
2. BREAK EDGES 0.076 + 0.127 UNLESS OTHERWISE SPECIFIED.
3. MATERIAL: STEEL, CARBON; ASTM A108; SAE 1117, 1118.
4. FINAL PROTECTIVE FINISH: FINISH 5.3.1.2 OR 5.3.2.2 OF MIL-STD-171.
5. ASME Y14.5M-1994 APPLIES.

REVISIONS				
ZONE	REV.	DESCRIPTION	DATE	APPROVED
	A	CREATE DRAWING	8/11/2015	G. HERSHBERGER

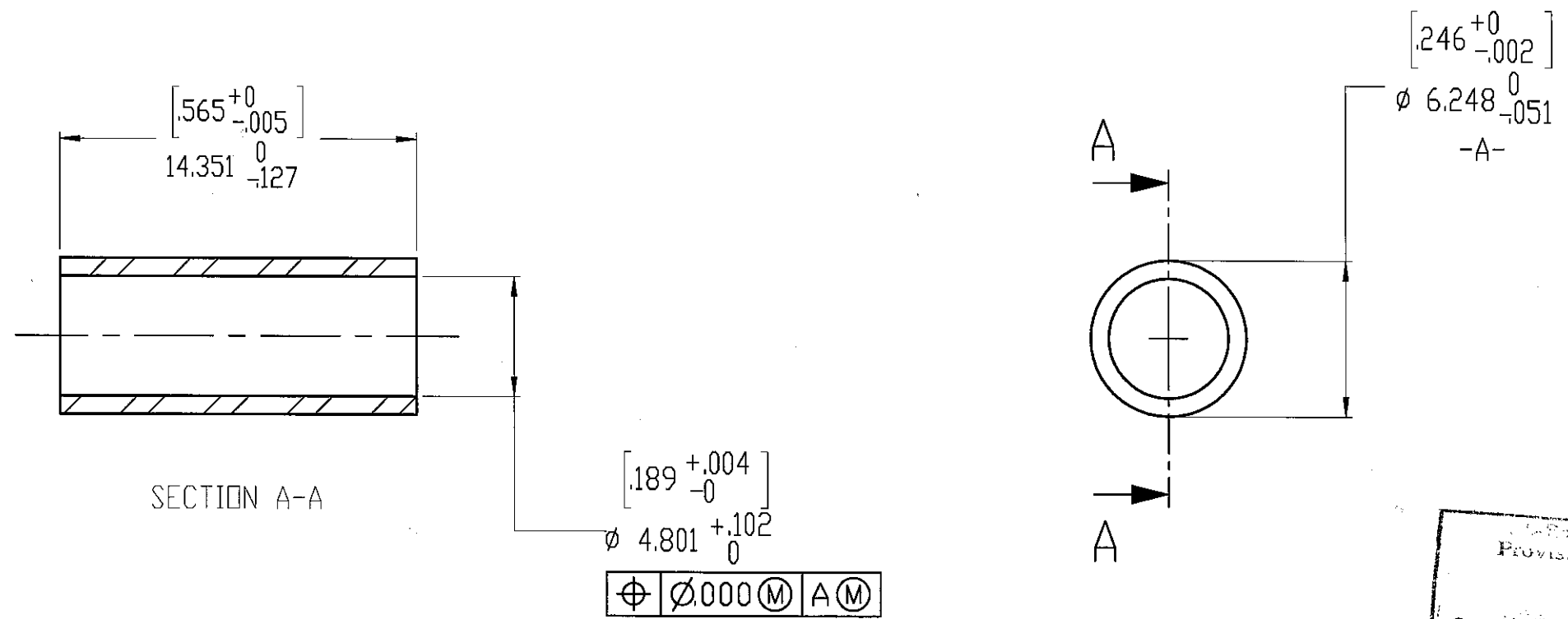

Provisionally Approved

24 AUG 2021

DRG/SIG

Per Cmde (AP)

<p>ITAR CONTROLLED</p> <p>THIS DOCUMENT IS CONTROLLED UNDER THE ITAR. IT MAY NOT BE PROVIDED TO A NON-U.S. RESIDENT WITHOUT THE WRITTEN APPROVAL OF THE U.S. GOV'T. VIOLATIONS WILL RESULT IN CIVIL OR CRIMINAL PENALTIES.</p> <p>PROPRIETARY AND CONFIDENTIAL</p> <p>THE INFORMATION CONTAINED IN THIS DRAWING IS THE SOLE PROPERTY OF DHIO ORDNANCE WORKS, INC. ANY REPRODUCTION IN PART OR AS A WHOLE WITHOUT THE WRITTEN PERMISSION OF DHIO ORDNANCE WORKS, INC. IS PROHIBITED.</p>	<p>UNLESS OTHERWISE SPECIFIED</p> <p>DIMENSIONS ARE IN MM/(INCHES)</p> <p>ALL THREAD DIM. ARE IN INCHES</p> <p>TOLERANCES:</p> <p>FRACTIONAL</p> <p>ANGULAR: MACH ± BEND</p> <p>TWO PLACE DECIMAL ±0.25</p> <p>THREE PLACE DECIMAL ±0.127</p>	<p>NAME: PMD</p> <p>DATE: 08/10/15</p>	<p>DHIO ORDNANCE WORKS, INC.</p>
	<p>INTERPRET GEOMETRIC TOLERANCING PER:</p>	<p>DRAWN</p> <p>CHECKED</p> <p>ENG APPR.</p> <p>MFG APPR.</p> <p>Q.A.</p> <p>COMMENTS:</p>	<p>SLEEVE, BELT HOLDING PAWL, ØØW50BMG</p>
	<p>MATERIAL</p> <p>FINISH</p> <p>DO NOT SCALE DRAWING</p>	<p>SIZE: B</p> <p>7160627</p> <p>SCALE: 4:1</p> <p>WEIGHT:</p>	<p>REV: A</p> <p>SHEET 1 OF 1</p>

NOTES:

1. FINISH $\sqrt{32}$ EXCEPT AS NOTED.
2. BREAK EDGES 0.076 + 0.305 UNLESS OTHERWISE SPECIFIED.
3. HEAT TREATMENT: HEAT AT 829° - 843° C. OIL QUENCH. TEMPER ONE HOUR MINIMUM TO HARDNESS SPECIFIED (RH C46-52).
4. FINAL PROTECTIVE FINISH: FINISH 5.3.1.2 OR 5.3.2.2 OF MIL-STD-171.
5. ASME Y14.5M-1994 APPLIES.
6. MATERIAL:
 - A. WROUGHT MATERIAL: STEEL, ASTM A322 OR A331; 4140, 8645.
 - B. PRECISION CASTING: STEEL, MIL-S-22141; IC4140, IC8640. TENSILE TEST SHALL NOT APPLY. CASTING SHALL BE IN ACCORDANCE WITH CLASS 2, GRADE B OF MIL-STD-2175.

REVISIONS				
ZONE	REV.	DESCRIPTION	DATE	APPROVED
	A	CREATE DRAWING	8/11/2015	G. HERSHBERGER
C3	B	ADDED ENGRAVING INFORMATION	7/30/2018	J. HERSHBERGER

M-170

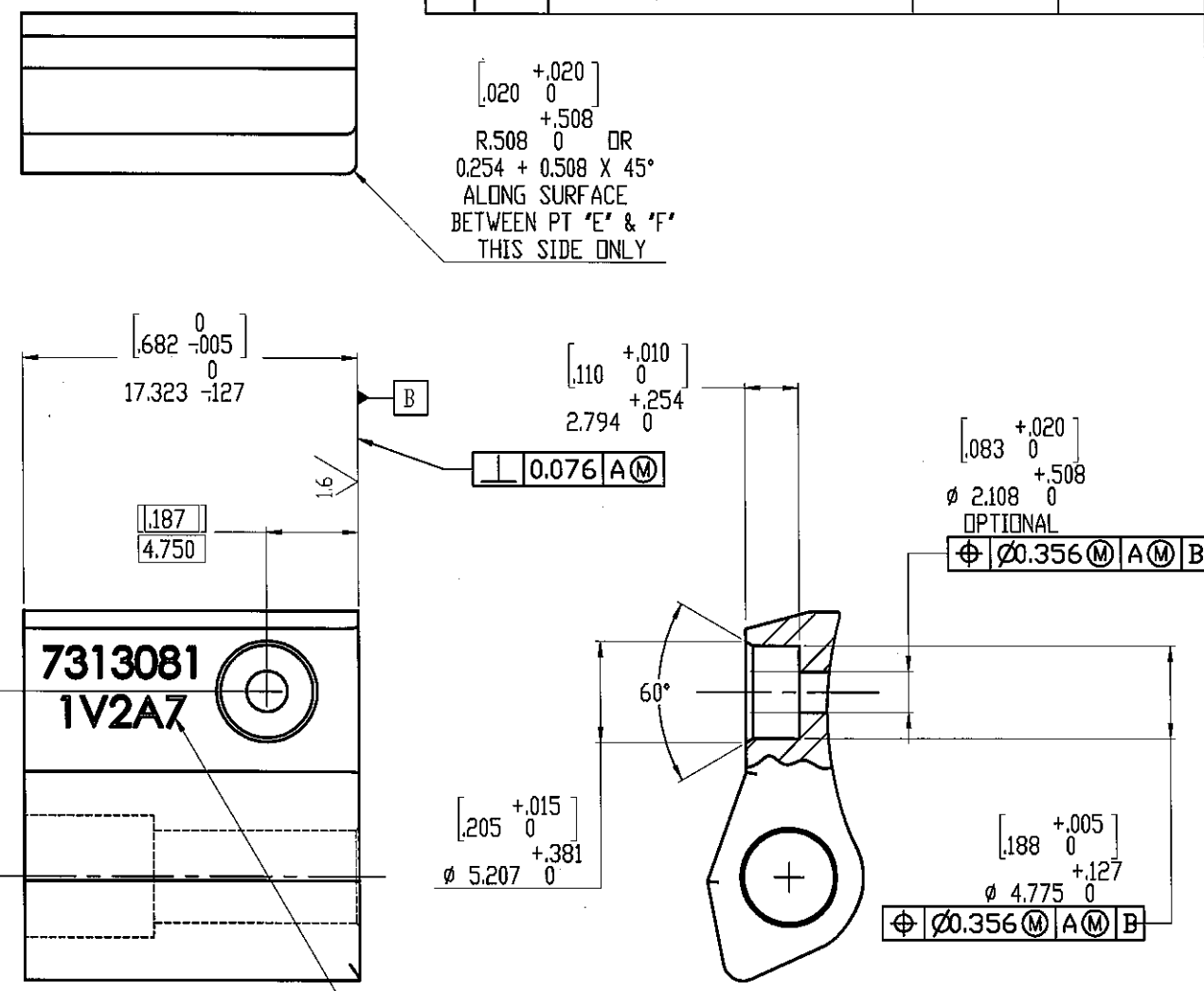
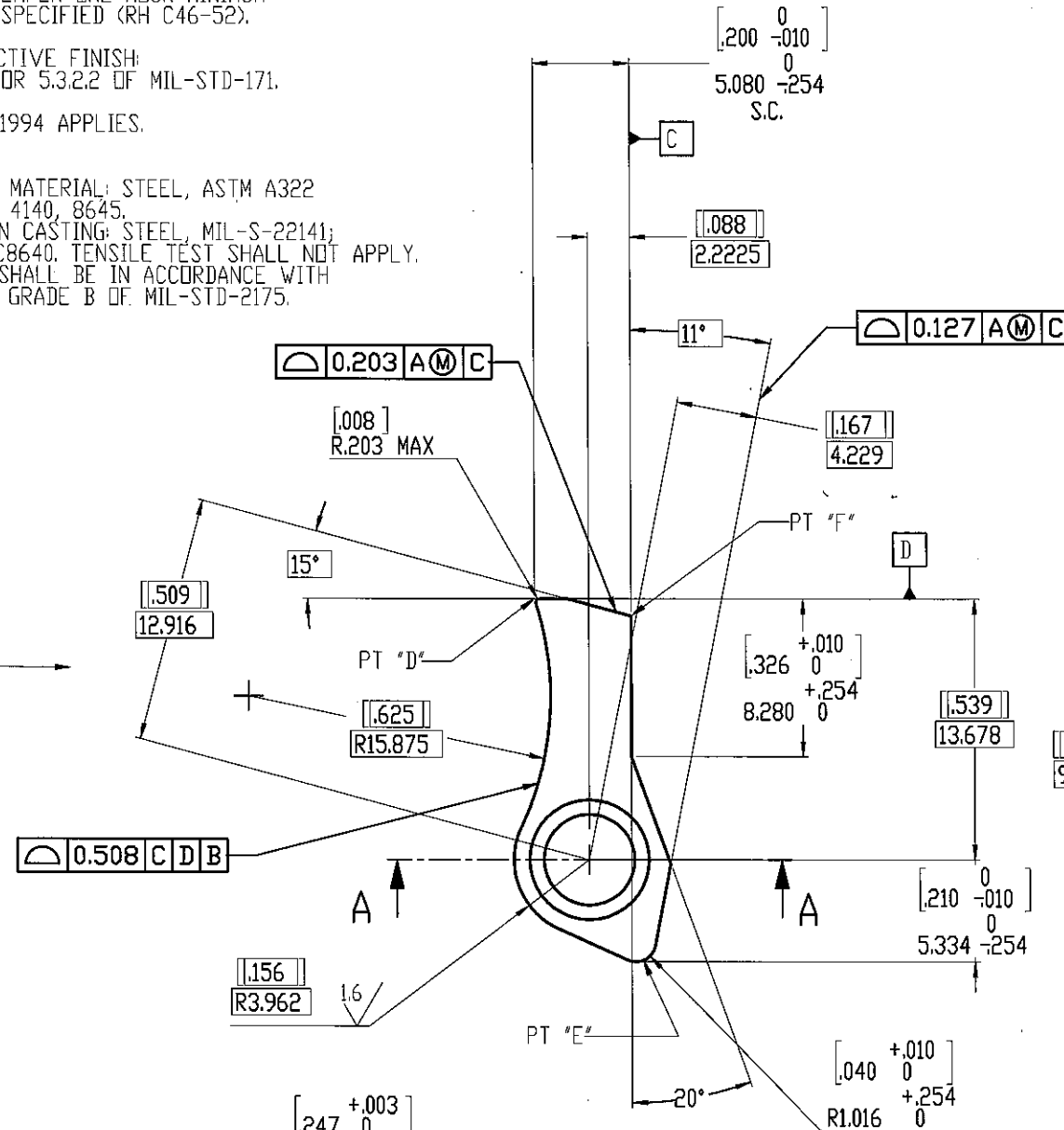

7313081
1V2A7

INSCRIBE OR CAST PART NUMBER 7313081 AND PRIME CONTRACTOR'S CAGE CODE IDENTIFICATION 1.575 ± 0.381 HIGH X 0.127+ 0.381 DEEP

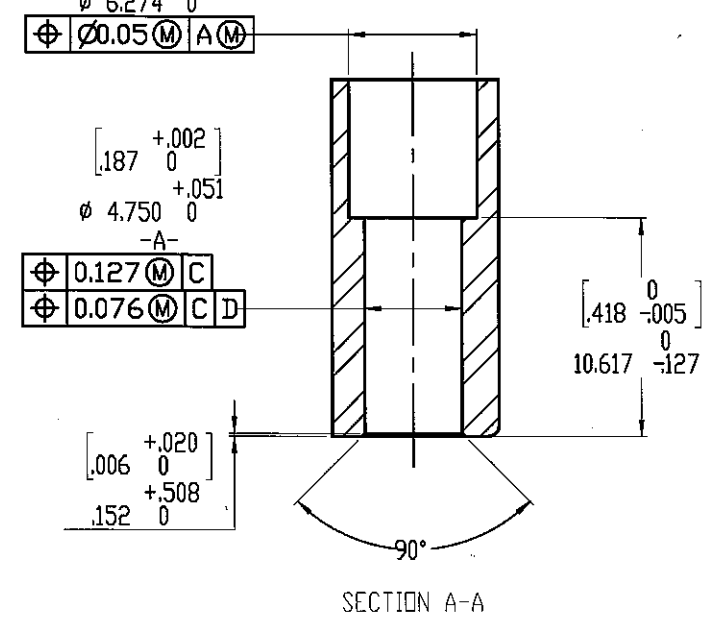

24 AUG 2021

Per (mde (API))

<p>ITAR CONTROLLED</p> <p>THIS DOCUMENT IS CONTROLLED UNDER THE ITAR. IT MAY NOT BE PROVIDED TO A NON-US RESIDENT WITHOUT THE WRITTEN APPROVAL OF THE U.S. GOVT. VIOLATIONS WILL RESULT IN CIVIL OR CRIMINAL PENALTIES.</p> <p>PROPRIETARY AND CONFIDENTIAL</p> <p>THE INFORMATION CONTAINED IN THIS DRAWING IS THE SOLE PROPERTY OF DHID ORDNANCE WORKS, INC. ANY REPRODUCTION IN PART OR AS A WHOLE WITHOUT THE WRITTEN PERMISSION OF DHID ORDNANCE WORKS, INC. IS PROHIBITED.</p>	UNLESS OTHERWISE SPECIFIED DIMENSIONS ARE IN MM/(INCHES) ALL THREAD DIM. ARE IN INCHES TOLERANCES:	NAME	DATE	<p>DHID ORDNANCE WORKS, INC.</p> <p>PAWL, BELT HOLDING, LEFT HAND, DDW50BMG</p> <p>SIZE C 7313081 REV B</p> <p>SCALE: 4:1 WEIGHT: SHEET 1 OF 1</p>	
	FUNCTIONAL	DRAWN	PWD		08/10/15
	ANGULAR: MACH ± BEND TWO PLACE DECIMAL ±0.25 THREE PLACE DECIMAL ±0.127	CHECKED			
	INTERPRET GEOMETRIC TOLERANCING PER:	ENG APPR.			
MATERIAL	MFG APPR.				
FINISH	Q.A.				
DO NOT SCALE DRAWING	COMMENTS:				

NOTES:

1. FINISH $\sqrt{3.2}$ EXCEPT AS NOTED.
2. BREAK EDGES 0.076 + 0.305 UNLESS OTHERWISE SPECIFIED.
3. HEAT TREATMENT: HEAT AT 829° - 843° C. OIL QUENCH. TEMPER ONE HOUR MINIMUM TO HARDNESS SPECIFIED (RH C46-52).
4. FINAL PROTECTIVE FINISH: FINISH 5.3.1.2 OR 5.3.2.2 OF MIL-STD-171.
5. ASME Y14.5M-1994 APPLIES.
6. MATERIAL:
 - A. WROUGHT MATERIAL: STEEL, ASTM A322 OR A331; 4140, 8645.
 - B. PRECISION CASTING: STEEL, MIL-S-22141; IC4140, IC8640. TENSILE TEST SHALL NOT APPLY. CASTING SHALL BE IN ACCORDANCE WITH CLASS 2, GRADE B OF MIL-STD-2175.

REVISIONS				
ZONE	REV.	DESCRIPTION	DATE	APPROVED
	A	CREATE DRAWING	8/11/2015	G. HERSHBERGER

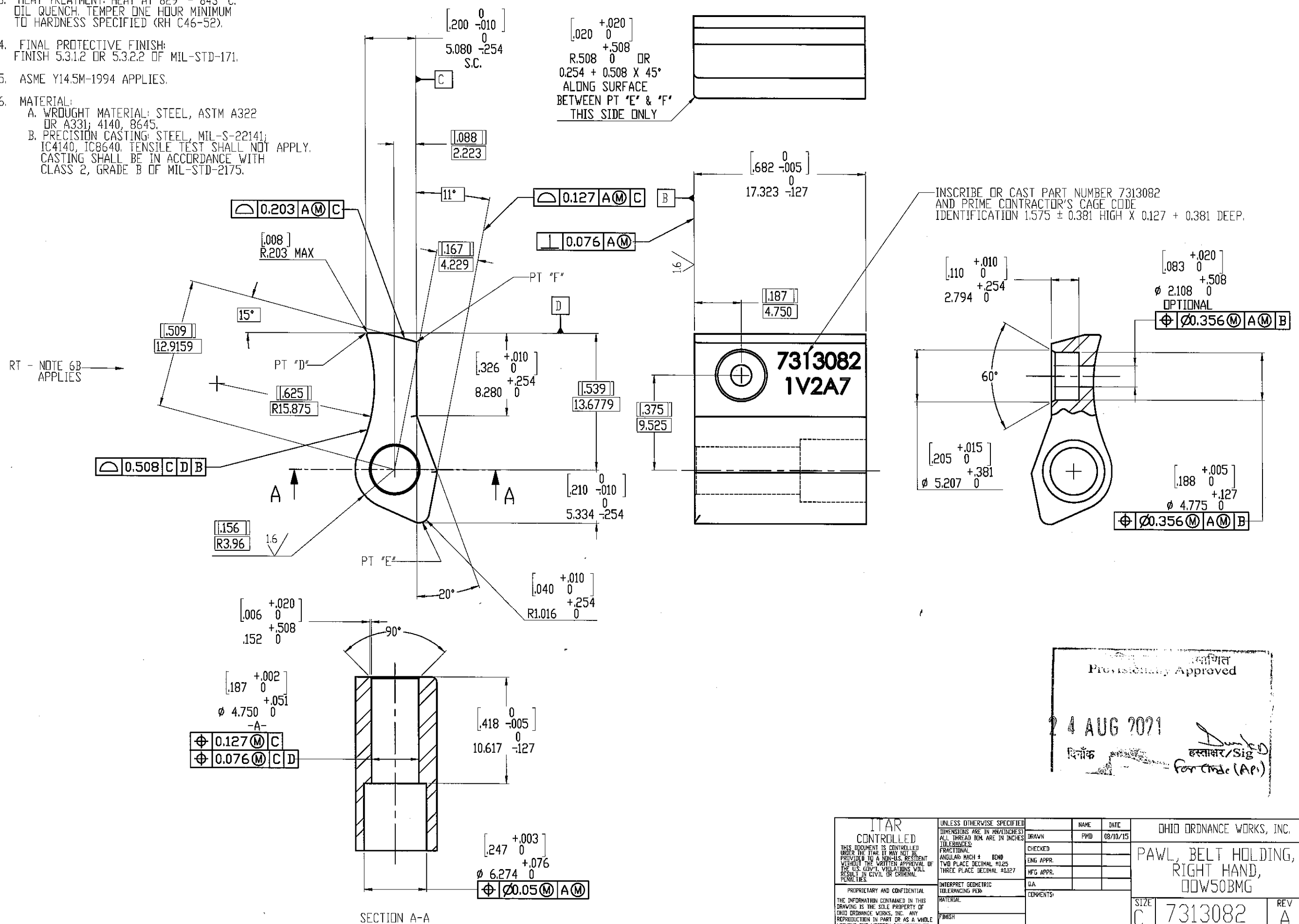

ITAR CONTROLLED		UNLESS OTHERWISE SPECIFIED		NAME		DATE		DHIO ORDNANCE WORKS, INC.	
THIS DOCUMENT IS CONTROLLED UNDER THE ITAR IT MAY NOT BE PROVIDED TO A NON-US RESIDENT WITHOUT THE WRITTEN APPROVAL OF THE U.S. GOVT. VIOLATIONS WILL RESULT IN CIVIL OR CRIMINAL PENALTIES.		DIMENSIONS ARE IN MM/(INCHES) ALL THREAD DIM. ARE IN INCHES TOLERANCES: FRACTIONAL ANGULAR: MACH ± BEND TWO PLACE DECIMAL ±0.25 THREE PLACE DECIMAL ±0.27		DRAWN	PMI	08/10/15	PAWL, BELT HOLDING, RIGHT HAND, DDW50BMG		
PROPRIETARY AND CONFIDENTIAL THE INFORMATION CONTAINED IN THIS DRAWING IS THE SOLE PROPERTY OF DHIO ORDNANCE WORKS, INC. ANY REPRODUCTION IN PART OR AS A WHOLE WITHOUT THE WRITTEN PERMISSION OF DHIO ORDNANCE WORKS, INC. IS PROHIBITED.		INTERPRET GEOMETRIC TOLERANCING PER:		CHECKED			SIZE C 7313082 REV A		
		MATERIAL:		ENG APPR.			SCALE: 4:1 WEIGHT: SHEET 1 OF 1		
		FINISH:		MFG APPR.					
		DO NOT SCALE DRAWING		QA					
				COMMENTS:					