

**RESTRICTED
(DRAFT/PROVISIONAL)
QUALITY ASSURANCE PLAN**

FOR

(GUARD ALUMINIUM SHEET sAMG6BM-2S/ GUARD)

DRG.NO.172.11.074-1

(LF NO: 6206109021)

**No.HVF/T-72/QAP/11/GUARD ALUMINIUM SHEET
sAMG6BM-2S/ GUARD/244228-00**

ISSUE No: 00

DATE: JULY-2022

QUALITY ASSURANCE (RIG-OE)

HEAVY VEHICLES FACTORY

AVADI CHENNAI – 600 054

QUALITY ASSURANCE PLAN (QAP)

FOR

GUARD ALUMINIUM SHEET sAMG6BM-2S/ GUARD

DRG. NO. 172.11.074-1

PREPARED BY

(C.NANDA KUMAR)
JWM/QA (RIG-OE)

REVIEWED BY

(AWNEESH YADAV)
JWM/QA (RIG-OE /TA)

APPROVED BY

(SUBHAM BIJLWAN)
AWM/QA-RIG-(OE)

ISSUED BY

QUALITY ASSURANCE (RIG- OE)
HEAVY VEHICLES FACTORY
AVADI CHENNAI – 600 054

Sl. no	CONTENTS	PAGE .No.
1.	IMPORTANT NOTES	4
2.	INTRODUCTION	4
3.	AIM	4
4.	SCOPE	5
5.	DOCUMENTS	5
6.	ITEM USED ON	6
7.	LIST OF DRAWINGS	6
8.	BILL OF MATERIAL	6
9.	CONDITIONS OF USE/ STORAGE INSTRUCTIONS	6
10.	SAMPLING PLAN	7
11.	VISUAL INSPECTION	7
12.	DIMENSIONAL CHECKS	8
13.	MATERIAL CHECKS	8
14.	ACCEPTANCE / PERFORMANCE TESTS	9
15.	FITMENT AND PERFORMANCE TEST	10
16.	INTERCHANGEABILITY	11
17.	CALIBRATION CHECKS	11
18.	MARKING/IDENTIFICATION	11
19.	PRESERVATION CHECK	11
20.	PACKING CHECK	11
21.	DOCUMENTATION	12
22.	REFERENCE	12
23.	ANNEXURE-A	13
24.	FIGURE	14
25.	APPENDIX-A	15

1.IMPORTANT NOTES

Note-1

This is only a provisional and will be amended from time to time according to the requirement. No addition, deletion and reproduction will be done without permission of The Chief General Manager, Heavy Vehicles Factory, Avadi, Chennai – 54.

Note –2

Any instruction contained in this does not prejudice the terms and conditions of the contract what so ever. In case of any contradiction between the contents of this QAP and the clause in the contract, the latter will prevail.

Note-3

The stores should be manufactured strictly only as per the drawings supplied by the Inspection Authority and not as per the samples, if any received by the manufacturer for guidance purpose.

Note-4

Any amendment issued by the Inspection Authority shall be incorporated in the QAP and the records for the amendments carried out should be maintained as per the Performa at Appendix-"A".

Note-5

In case of any contradiction between the contents of this QAP and drawings/specifications/GOST issued along with the contract, the latter only will prevail.

2.INTRODUCTION

1. This quality plan lays down the inspection and testing procedure to be carried out on the component **GUARD ALUMINIUM SHEET sAMG6BM-2S/ GUARD TO DRG.NO 172.11.074-1** being procured indigenously. This is prepared, based on the acceptance standards and inspection parameters laid down in collaborators documents and on the inspection test standards followed in respect of similar indigenious items.
2. This QAP is the property of Government of India and is liable for amendments as and when required. The Chief General Manager, Heavy Vehicles Factory, Avadi, Chennai – 600 054, is the inspecting Authority for this assembly. Any query / clarification on the content of this QAP shall be referred to this Factory. Any departure from these instructions is allowed only after written approval from the above authority. Notwithstanding the tests indicated in this QAP, the inspecting Officer has the right to carry out any test to check conformance to the paper particulars quoted in the Supply Order, which he may consider necessary to satisfy himself about the stores which he has to accept.

3.AIM

The QAP is aimed at standardizing the Inspection procedure and acceptance norm for **GUARD ALUMINIUM SHEET sAMG6BM-2S/ GUARD TO DRG.NO:172.11.074-1.**

It also aims at giving adequate information to the manufacturer on the quality requirements so that the required quality control methods are established. This is also meant to guide authorized Inspection Officer in his routine inspection and to set out main points to which his attention must be drawn to ensure that the accepted stores meet the stipulated standards.

4. SCOPE:

This QAP outlines in general terms, the checks and methods to be used during inspection of **GUARD ALUMINIUM SHEET sAMG6BM-2S / GUARD TO DRG.NO.172.11.074-1** including the technical requirements of the drawings. The recommended Quality Plan stipulated herein is mandatory and should be strictly adhered to.

For inspection purpose, only the latest issue of this QAP will be made applicable and copies of this QAP can be obtained from the issuing authority i.e. The Chief General Manager, Heavy Vehicles Factory, Avadi, and Chennai.

Note:

- i. Tender enquiry (TE) and supply order (S.O) will be issued with QAP stating that inspection will be done as per QAP.
- ii. In case of TE, It is responsibility of the vendor to obtain the copy of QAP and give the statement of compliance that vendor will abide by the QAP in case supply order is placed.
- iii. In case of S.O, it is the responsible of the vendor to obtained copy of QAP and give the statement of compliance that the vendor will follow QAP. However, GM/HVF reserves the right to revise/update the QAP from time to time.

5. DOCUMENTS:

- a) On placement of firm supply order, One set of relevant specification and technical instructions on the subject item to be obtained by the contractor from AHSP through DDO/HVF
- b) Any clarification required on these documents to be obtained from the Inspecting Authority i.e. The Chief General Manager, Heavy Vehicles Factory, Avadi, Chennai – 600 054. Equivalent to the collaborators specifications and standards will be decided only by the Inspecting Authority and should not be unilaterally decided. For any change in the specifications, standards or written approval, any alterations in specification can be affected and not otherwise.
- c) The process instruction sheets supplied by the collaborators are available with the Authority Holding Sealed Particulars, i.e. The Controllerate of Quality Assurance (Heavy Vehicles), Avadi, Chennai for the reference. The relevant process sheets may be studied at the premises of the AHSP after obtaining necessary permission.
- d) The supplier after scrutiny of the concerned process sheets and connected paper particulars should establish the necessary production and inspection facilities.

Particularly the inspection test rigs, stands, fixtures, template, gauges etc should be provided as recommended in these process sheets. If process sheet / Process Book is not available the details particulars/parameters available in the drawings to be strictly adhered.

6. ITEM USED ON:

1) 172.11.026CB-1

7. LIST OF DRAWINGS:

SI. NO.	DRG. NO	NOMENCLATURE	REMARKS
1	172.11.074-1	GUARD ALUMINIUM SHEET sAMG6BM-2S/ GUARD	-

8. BILL OF MATERIALS:(Individual items as mentioned in table to Para 7)

SI. NO	DRG. NO	NOMENCLATURE	MATERIAL SPECIFICATIONS	Qty
1	172.11.074-1	GUARD ALUMINIUM SHEET sAMG6BM-2S/ GUARD	SHEET AMГ 6BM-2 GOST 21631-76	1

Note: Vendor/Contractor may use approved alternate material, if any specified in drawing/specification.* Also refer Para no: 13.

9. CONDITIONS OF USE/STORAGE INSTRUCTIONS

This assembly/item should be properly packed to protect from transit / handling damage and influence of atmospheric precipitations. In addition, the following parameters should be ensured:

- (a) The threaded parts if any should be covered with suitable plastic caps to prevent damages.
- (b) If the item consists of assemblies, each assembly should be packed separately.
- (c) The stores are to be suitably covered for preventing ingress of dust and Dirt/entry of sunlight / moisture.
- (d) The packaging slip shall contains
 - (i) Certificate of testing- NABL Certificate.
 - (ii) Guarantee/ Warranty Certificate.
 - (iii) Service and maintenance instructions.
 - (iv) Delivery Slip with Inspector's Acceptance Mark.
 - (v) Undertaking letter / Certificate of conformance (As applicable).

- (e) The stores are not permitted to be stored together with oils. Petrol, acids, alkaline and other substances to avoid damage to the metal / rubber components.

10. SAMPLING PLAN:

Sl. No.	Sampling Plan	Pilot	Bulk
Acceptance test (As below)			
(i)	Visual Inspection	100%	100%
(ii)	Dimensional Inspection	100%	General Inspection level III, single sampling, Normal Inspection, AQL 2.5 of IS 2500 (Part-I)-2000
(iii)	Material Inspection (including Chemical, Mechanical & Physical properties)	1 No	1 No. or Qty as specified in specification, GOST for each batch of raw material or heat treatment lot/ As required for confirmation of material.
(iv)	Pressure testing	----	-----
(v)	Machining/Fitment/ Performance trial on higher assembly / Tank	01 No.	01 No. per batch / As required.
(vi)	Interchangeability Test	----	-----
(vii)	Calibration Reports/Certificates of Test stand/Jigs/ Equipments/Fixtures/ Gauges/Mandrels/etc.	100 %	100 %
(viii)	Marking/Identification	100%	100%
(ix)	Packing/ Preservation	100%	100%

Note:-

A New (First time supplier of this item) supplier should obtain clearance from HVF for bulk production which will be issued only after inspection/evaluation of pilot samples by HVF.

11. VISUAL INSPECTION [Sampling plan as per Para- 10 (i)]

The stores are to be visually examined on 100 % of pilot /bulk and same should be free from any defects and all the finishing requirements shall satisfy as indicated in technical conditions of the assembly / component drawing.

The components shall be checked for the following and should be free from the defects:

- Defects in construction
- Cracks/Dents/Scratches
- Fitment of all components
- Presence of foreign particles
- Moisture and dust
- Corrosion of metal parts
- Mechanical imperfections & distortion
- Any form of deterioration of material and finishing.

Packing and preservation should be ensured as per drawings/relevant TY specification (To be ensured on receipt at consignee end).

12. DIMENSIONAL CHECK[Sampling plan as per Para- 10(ii)]

The dimensions of individual component, sub assembly and major assembly shall be checked and ensured as per respective drawing. Dimensional check should be carried out as per sampling plan. However, the inspecting authority/rep. may at his discretion, tighten the inspection level and acceptance quality level on the critical items and adopt check point during ALUMINIUM SHEET sAMG6BM-2s manufacture.

12.1 GUARD ALUMINIUM SHEET sAMG6BM-2S/ GUARD TO DRG.NO 172.11.074-1

1. All dimensions shall be confirmed as per drawing/specification.
2. Surface finish/Roughness should be confirmed as per drawing and specification.
3. For admissible alternate method for manufacture in dimensions/material if any, refer drawing/specification.

13) MATERIAL CHECKS [SAMPLING PLAN AS PARA – 10 (iii)].

Material specimen /test bars of the components shall be in conformity as per the material mentioned in the relevant documents/drawing. NABL test reports for all the parameters as per relevant specifications to be submitted. Test samples to be submitted by the vendor to HVF, if required. The material check will be carried out as per sampling plan. However, if the manufacturer proposes any alternative material at the stage of tender enquiry, the same has to be approved and a written concurrence should be obtained from AHSP through DDO/HVF, before usage of such materials.

13.1 GUARD ALUMINIUM SHEET sAMG6BM-2S/ GUARD TO DRG.NO 172.11.074-1

- a) The component should be manufactured from
SHEET AMГ 6БМ-2 GOST 21631-76
- b) **Chemical properties:** As per SHEET AMГ6Б&AMГ6 GOST 21631-76

GRADE	ALLOY ELEMENTS		ADMIXTURES % MAXIMUM									OTHER ADMIXTURE EACH	TOTAL
			Fe	Si	Cu	Mn	Zn	Ti	Mg				
AMГ6Б & AMГ6	Al	Zn	0.30	0.30	0.02	0.025	0.1	0.15	0.05	0.02	0.70		
	89.30 MIN.												

Note: For mass fraction of other elements refer GOST 21631-76.

c) Mechanical properties: As per SHEET AMГ6Б&AMГ6 GOST 21631-76

GRADE	TENSILE STRENGTH	YIELD POINT	ELONGATION
	Kgf/mm ²	Kgf/mm ²	%
	MINIMUM		
AMГ6Б & AMГ6	32.0	16.0	15.0

Note: For other parameters refer GOST 21631-76.

**14) PERFORMANCES/ACCEPTANCE TEST: GUARD ALUMINIUM SHEET
sAMG6BM-2S / GUARDTODRG.NO:172.11.074-1**

1. SURFACE RUPTURES, CRACKS AND BURRS ARE NOT ALLOWED.
2. THICKNESS AT PLACES OF BENDING AND PROFILE OF BULGES AFTER BENDING NOT TO BE CHECKED.
3. UNSPECIFIED RADII OF CUTS IN THE GUARD ARE TO BE 4 mm.
4. CIRCUMFERENCE ϕ 596 IS TO BE DIVIDED TO 120 EQUAL DIVISIONS. DIGITS TO BE PUNCH MARKED WITH 5-6 mm HIGH TYPE DEPTH OF MARKS AND DIGITS SHOULD BE 0.5 mm MIN.
5. RAISED TRACES OF MARKS NOT EXCEEDING 0.5 mm IN HEIGHT ARE ALLOWED ON SURFACE, OPPOSITE TO LOCATION OF THE MARKS.
6. SHIFT OF MARKS FROM TRUE POSITION SHOULD NOT EXCEED 0.3 mm. THIS IS TO BE ENSURED BY STAMPING. IN ONE PLACE VARIATION OF PITCH OF TWO ADJACENT DIVISIONS MAY BE UP TO 1 mm.

7. MANUFACTURE FROM SHEETS AMT 6M GOST 21631-76 IS ALLOWED.
8. BENDING CONTOUR OF COMPONENT IS TO BE CHECKED BY TEMPLATE, MADE TO NOMINAL DIMENSIONS. DEVIATION FROM THE TEMPLATE UP TO 1.5 mm IS ALLOWED.
9. MARKS, SCORES AND TRACES FROM TOOL ON COMPONENT SURFACE ARE ALLOWED.
10. ABSENCE OF ROUNDING OFF RADII OF PROFILE CORNERS AND UNEVENNESS OF EDGES OF CUT IN SLOTS ARE ALLOWED WITHIN THE LIMITS OF TOLERANCE ON DIMENSIONS.
11. UNEVENNESS OF SHOULDER ALONG $\phi 596 \pm 2$ SHOULD BE WITHIN THE TOLERANCE LIMITS.
12. THE DIMENSIONS IN BRACKETS MAY BE CARRIED OUT AS PER DRAWING
172.11.026 c6-1
13. LOCAL SHIFT OF DIGITS (NOT MORE THAN 7) TO THE EDGE OF THE COMPONENT IS ALLOWED, BUT THE DIGITS MUST BE PRINTED IN FULL.

14. EXPLANATORY NOTE:-

- a) REFERENCE MATERIAL QUOTED:- SHEET AMT 6BM-2 GOST 21631-76
SHEET MADE FROM ALUMINIUM ALLOY OF GRADE AMT 6 WITH TECHNOLOGICAL CLADDING (B) AND ANNEALED CONDITION (M) NORMAL ACCURACY ON THICKNESS $2.0^{+0.15}$ GOST 21631-76
- b) REFERENCE NOTE 7 ON ALTERNATIVE MATERIAL:- SHEET AMT 6M GOST 21631-76
SHEET MADE FROM ALUMINIUM ALLOY OF GRADE AMT 6 ANNEALED CONDITION (M) OF NORMAL ACCURACY ON THICKNESS $2.0^{+0.15}$ GOST 21631-76

15) FITMENT AND PERFORMANCE TEST:

- a. Pilot samples should be checked for fitment and Performance test to ascertain the efficacy of the system under different operating conditions by fitting in higher assembly and repeating it for functional checks, wherever required.
- b. Items of Bulk supplies may be subjected to performance trial in tank in case of repeated failure/defects during exploitation.

16) INTERCHANGEABILITY:

The assemblies/component should be interchangeable component wise and assembly wise, except the Component are to be supplied as a set and to be assembled selectively.

17) CALIBRATION CHECKS

(TEST STANDS/JIGS/FIXTURES/GAUGES/INSTRUMENTS):

The supplier / Contractor should have suitable Instruments, Test Stand, jigs, fixture, mandrels and gauges to carry out quality checks, to ensure conformance of components/assembly as per drawing and Specification /T.R points.

The supplier/contractor should submit calibration reports for instruments/fixtures/gauges/mandrels etc., which are used during process of inspection activities.

18) MARKING/IDENTIFICATION.

Marking of the items is to be carried out as called for in the relevant drawing, drawing/T.R points.

Inscription if any on the components is to be carried out as called for in the drawing/T.R points. Unless otherwise specified in the drawing/ specification, marking should not be carried out over the components.

For traceability, marking of part No., Manufacturer name, supply order No, Serial No/Qty, batch No. and manufacture date & year are to be carried out. Suitable method can be adopted, provided that the above parameters are legible and considering the parameters mentioned in the drawing and specification.

19) PRESERVATION CHECK

a) Preservative coatings are to be strictly adhered to as called for in the drawing. However, equivalent BIS Standards can also be followed, subject to the thickness of the coating/preservative is maintained as per the drawing/specification.

b) Other preservations as necessary to prevent damages due to moisture and dust during process, storage and transit are to be carried out. Conventional Methods can also be resorted to.

20) PACKING CHECK

Components / Assemblies are to be packed separately to avoid damages during transit / handling of the same. Part No. and No. of sets are to be marked on the packing.

Packing and preservation should be ensured as per drawings/relevant TY specification (To be ensured on receipt at consignee end).

Finished products shall be wrapped / packed using black and opaque polyethylene sheet or bags.

21) DOCUMENTATION

- i. Firm has to maintain all the documents as per QAP with respect to the SI.No.to have traceability.
- ii. Vendor has to submit Bill of materials, Material test reports, Class 'C' /Endurance test reports (wherever specified in drawing/TY specification/QAP) and Complete PIR (pre-inspection report) at the time of offering the item for inspection. HVF will commence inspection only after scrutiny of these documents.
- iii. The testing/inspection responsibility to test all the parameters as per QAP and drawing specifications as mentioned in Annexure -A (enclosed).
- iv. Pre inspection reports (PIR) of firm like, 1. Chemical analysis (NABL Certificate), 2.Mechanical properties (NABL Certificate), 3. Pre-forming process, 4. Coating certification (Wherever applicable), 5. Calibration reports of instruments and 6. 100 % Dimensional inspection reports and other relevant reports for acceptance of the item as specified in GOST/ Specification / drawings etc.

22) REFERENCE:

- a) Drawing No: 172.11.074-1.
- b) Material specification as per drawing:
SHEET AMГ 6BM-2 GOST 21631-76
- c) GOST 21631-76.
- d) Alternate/Equivalent Material:
1. SHEET AMГ 6M GOST 21631-76.

SL. NO.	CATEGORY	ASSEMBLY/ SUB ASSEMBLY	TESTS/ INSPECTION PARAMETERS	STANDARDS TO BE REFERRED	ACCEPTANCE CRITERIA	INSPECTION RESPONSIBILITY			REMARKS
						Firm	HVF	DGQA	
1	GUARD ALUMINIUM SHEET sAMG68M-2S/ GUARD TO DRG. NO 172.11.074-1	Pre inspection reports (PIR) of firm	Firm has to produce all the documents as per QAP	As per the relevant drawing and QAP.	Confirm to drawing and QAP as per bill of material	P	V	R	100% by firm/ vendor.
2		Bill of material (BOM)	Firm has to prepare the BOM as per QAP	Refer QAP Para no: 8 or item list.	Confirm to QAP	P	V	R	100% by firm/ vendor.
3		Dimensional checks	Dimensions as per the drawing	Refer drawing / QAP Para no: 12.1	Confirm to drawing and QAP	P	W/P	R	100% by firm/ vendor SP followed by HVF.
4		Material tests	Chemical composition & Mechanical / Physical Properties	As per-GOST 21631-76	All the values to confirm with QAP (Para no:13.1 (a), (b), (c))	P	W/V	R	100% by firm/ vendor SP followed by HVF.
5		Marking / traceability	Marking / traceability	Refer QAP Para no:18	Confirm to QAP Para no: 18	P	V	R	100% by firm/ vendor.
6		Preservation & packing	Preservation & packing	Refer QAP Para no 19 & 20	Confirm to QAP Para no 19 & 20	P	V	R	100% by firm/ vendor.

Note:

For conformity of the items (Chemical/Physical/Mechanical properties).

1. One sample per heat / batch shall be tested under NABL Lab/Govt. Approved lab by firm. In case of non-compliance to standards entire lot shall be rejected or not to use in production further.
2. For cross conformation of material, manufacturer has to submit test sample pieces for the items used / test slab and button for rubber items / HVF will draw samples from supplied lot for Witnessing (W) at HVF premises. In case of non-compliance to standards entire lot will be rejected.
3. All other relevant tests as specified in GOST/ Specification/ Drawing is to be carried out by firm and to be confirmed.

P-Perform W-Witness V-Verify R-Review SP-Sampling Plan

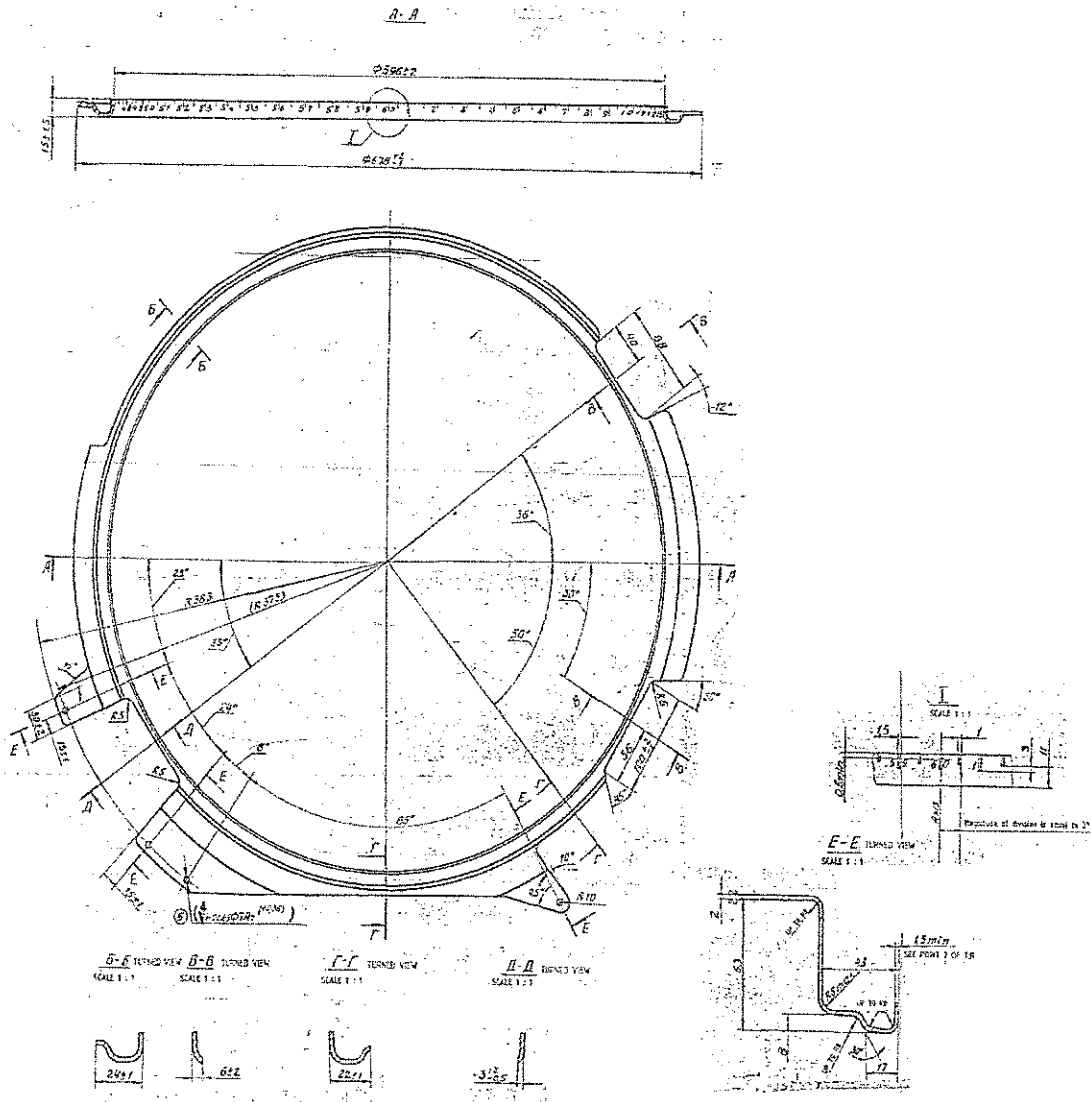

FIG: GUARD ALUMINIUM SHEET sAMG6BM-2S/ GUARD TO DRG.NO.172.11.074-1. (For reference only)

