

D.S.CAT. 1005-001690

1.02 x 45° CHAM.

DIMNS. ARE IN mm.

FOR EXPLANATION OF DIMENSIONING ETC. SEE D.D. NOTE SHEET NO.3 (LATEST ISSUE)

A  
B  
C  
D

A  
B  
C  
D

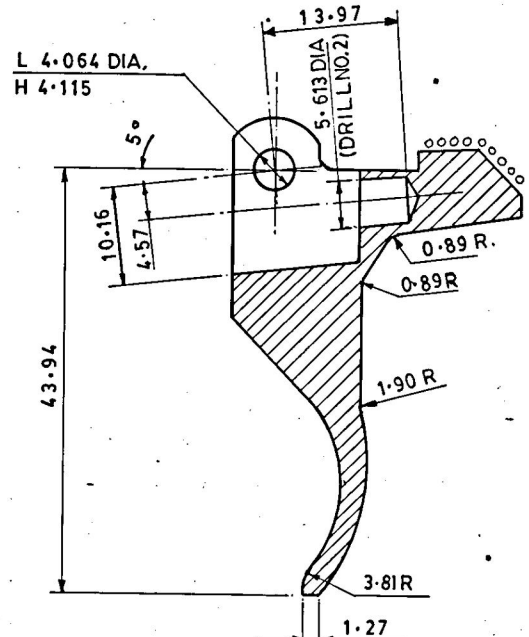
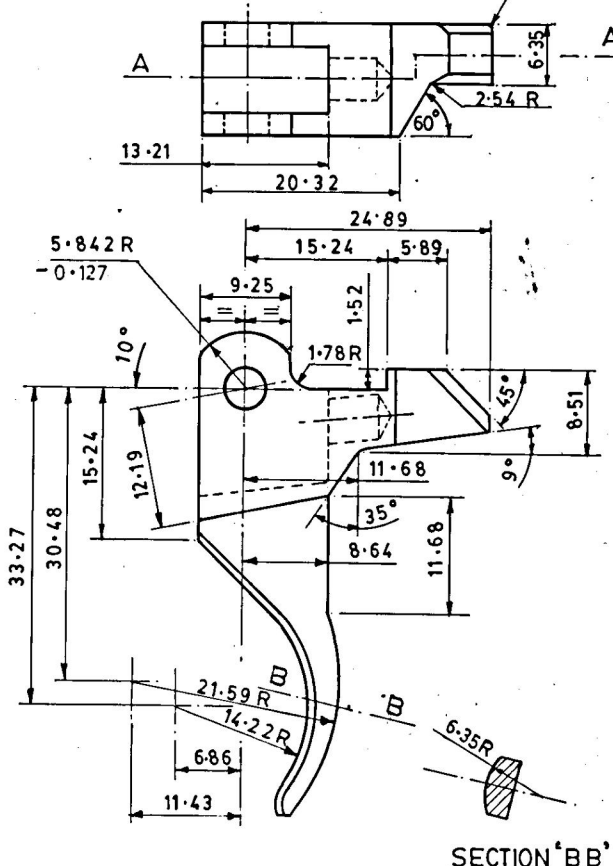
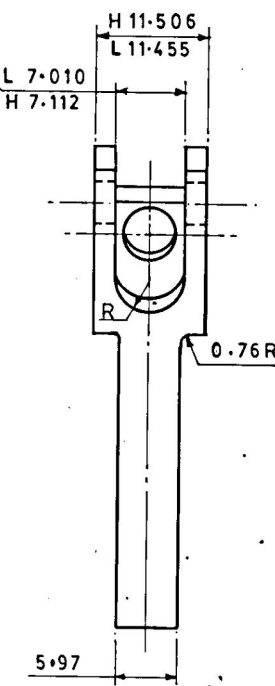

SECTION 'BB'

SECTION 'AA'

**FINISH :-**  
 THUMB PORTION :- PHOSPHATE TO SPECN. JSS:0465-01:1988  
 CLASS I PAINT RFU FINISHING AMMUNITION STOVING BLACK SPRAYING FOR SMALL ARMSTO SPECN. JSS: 8010-37.

**REST PORTION :-** PHOSPHATE TO SPECN. JSS:0465-01:1988  
 CLASS I OIL FINISH.

**NOTE :-**  
 FOR SPECN. LATEST ISSUE SHOULD BE FOLLOWED.

METRIC

				DRN.	CHD.	TRD. <i>Sachin</i>	COMP. <i>MS</i>	AHSP CQA(SA), ICHA PUR
				SCALE :- 2 : 1		EST. MASS		
12-5-99	24361-SA	PROFORMA CHANGED & REDUCED, FINISH NOTE AMENDED, NEG. RE-TRACED AND DRG. RE-SEALED		<i>Anles</i>	<i>Pray</i>	APPROVED NEG. RE-TRACED		
		PREVIOUS D.C. NOS. 14991-SA, 17584-SA, 17686-SA, 17760-SA & 19638-SA		DAC COPY		MATERIAL :- STEEL BS 970 PT.1 SEC.2 Gr.070 M55		
DATE	AUTHY.	BRIEF RECORD		ZONE	I/C;D.O.	G.O.		PART NO.
SEALED :- D.C. NO. 14991-SA, DT. 14.1.77				SIGN.		0000 HARDNESS :- 400 - 475 H.V. H.T / HARDNESS :- REST OF THE BODY 240 - 260 H.V. (56 - 61.5 HRD)		DRG. NO.
NOMENCLATURE :-		<b>TRIGGER</b>				PROTECTIVE FINISH		D.S.CAT. NO. 1005-001690