

DRAWING NO.  
54.05.272-1/F

MODIFICATIONS & ADDITIONS

ISSUE	MODIFICATIONS & 'N' OF 'A'	SIGN.

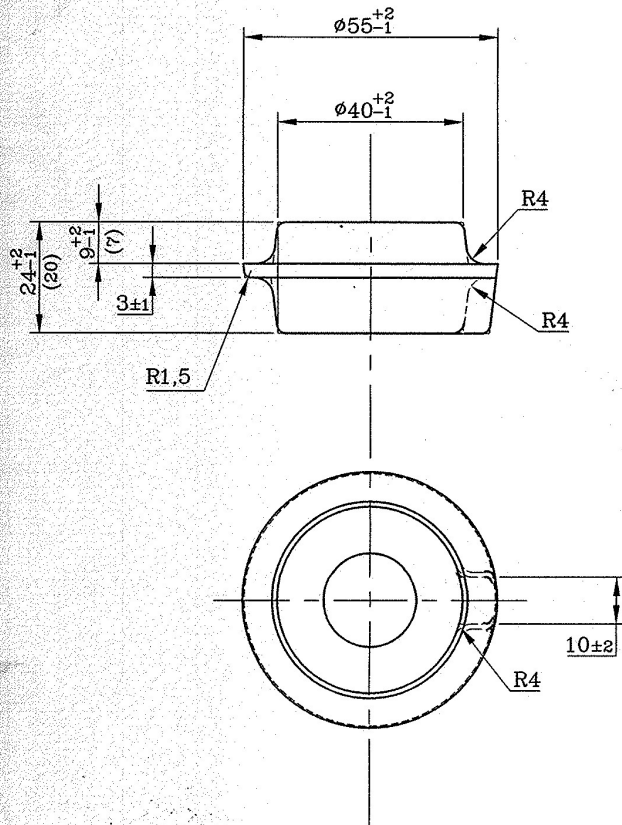

TECHNICAL REQUIREMENTS.

01. DE-SCALES(SHOT BLASTINGS)
02. IN MACHINING SURFACES,SURFACE DEFECTS AND SCALE PITS ARE ALLOWED UPTO 0.5 OF ACTUAL MACHINING ALLOWANCE.IN UNMACHINED SURFACES,WITHIN TOLERANCE LIMITS.
03. MISMATCH SHOULD NOT EXCEED 0.7 MM.
04. RESIDUAL FIN ALONG THE PARTING LINE SHOULD NOT EXCEED 1.0 MM.
05. ALTERNATIVE MATERIAL STEEL 20 GOST 1050-74.
06. UNSPECIFIED DRAFTS ANGLE  $7^\circ$
07. UNSPECIFIED RADII R.2.0 MM.
08. MACHINING DIMENSIONS ARE SHOWN IN BRACKETS.
09. UNTOLERANCED DIMENSIONS ARE FOR CONSTRUCTION.
10. MARK PART NO.
11. PAINT RED OXIDE.

MATERIAL	FORGING WT.	
STEEL 15 GOST1050-74	0.285 KGS	
ALT. MATERIAL	HAMMER	SCALE
		1:1
DRAWN	CHECKED	APPROVED
 A. Srinivasan 17.08.04	 M. Srinivasan	 S. Srinivasan 23.08.04
DRAWING NO. 54.05.272-1/F		
NOMENCLATURE: FLANGE		
HEAVY VEHICLES FACTORY AVADI,CHENNAI		

NOTES:-  
TRADE SUPPLIES IN NORMALISED CONDITION.