

1. *Dimension is given for reference.
2. When primer (fuse) device is switched on with a nominal voltage of 19 V, for 60 seconds, with strength of current should be 11 ...12 A; external temperature of housing for 90...100 seconds after switching - on should be within the limits of 1040..1150°C.
3. The airtightness of joints of parts (items 1 and 2) should be checked at pneumatic pressure of 1180 kPa (12kgf/cm²) for 25 seconds.
4. Tightening torque of nut (item 4) should be minimum Mkp 1.96 Nm (0.2 kgf m) and it should be caulked from two sides as per turn. Rotation of nut is not allowed after caulking.
5. Dimension A is ensured by compressing radially.
6. The item type, voltage value, production date, should be marked by rolling method, where first two digits specify the month and two last digits specify the year of manufacture, Font is ПО-2.5 as per Gost 2930-62 (ref. table).
7. Other technical requirements are as per TY 37.0031238-84.

Item type	Voltage Value	Example of marking of production date
1702.3740	19B	10-84

DRG. INDIANISED BASED ON RUSSIAN ORIGINAL ISSUE - NIL

PILOT SAMPLE SHOULD BE APPROVED BY A H S P BEFORE BULK PRODUCTION.

EST. WT.(Kg) **0.042** TO BE STAMPED OR MARKED WHERE INDICATED THUS # (LETTERS)

ALL SHARP EDGES AND CORNERS TO BE REMOVED UNLESS OTHERWISE STATED MACHINED CORNERS TO HAVE R OUT-SIDE R INSIDE EQUIVALENT CHAMFERS ARE PERMISSIBLE.

ISSUE	DATE	NATURE OF AMENDMENTS
A	18-8-08	D. O. CORRECTION.

DRN	83
CHD	[Signature]
APPD	[Signature]
DATE	14-2-08
SCALE:-	2:1
DIMENSIONS IN mm	
TOLERANCE ON DIMNS UNLESS OTHERWISE STATED IS :	2102 - 69
ALL THREADS TO CONFORM TO	

MATERIAL :-	USED ON :-
	Cb 345-00-4
CONTROLLERATE OF QUALITY ASSURANCE (HEAVY VEHICLES) AVADI	
TITLE :-	GLOW PLUG PIN TYPE
D S CAT NUMBER	DRAWING NUMBER
	Cb.17.3740.000

F-6
83
106

SIZE A3

DRG. INDIANISED BASED ON RUSSIAN ORIGINAL ISSUE - NIL

DRAWING NUMBER
17.3740.000ГЧ

SHEET No. 1 OF 1

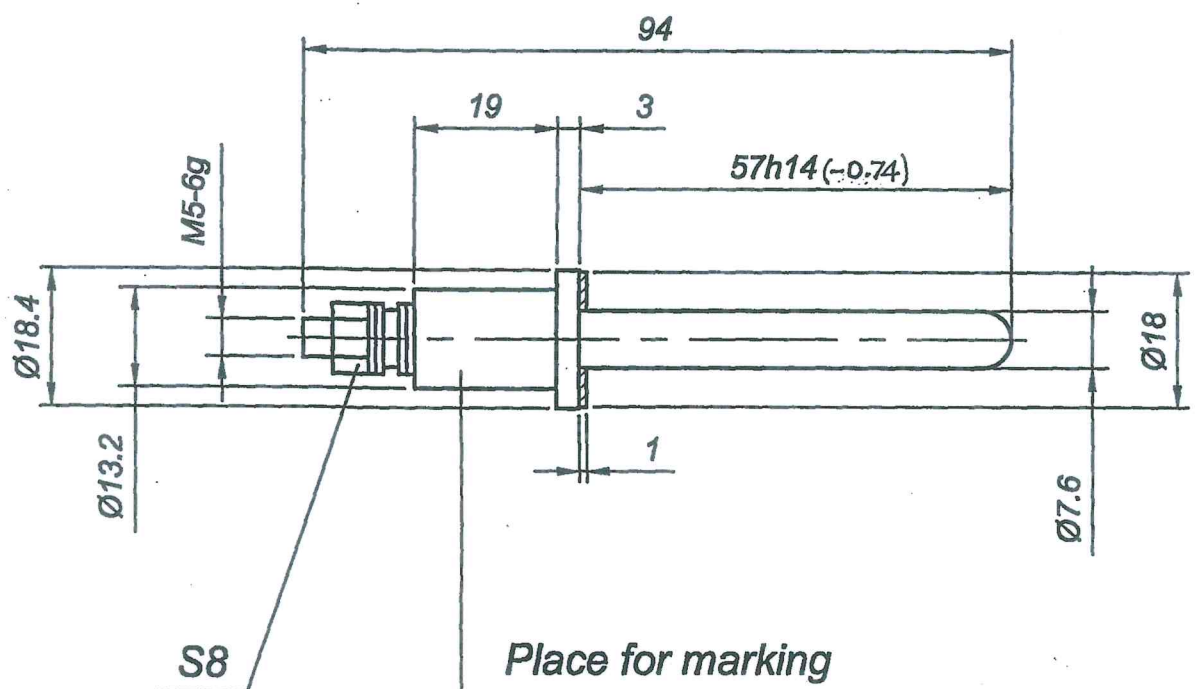

F-6
84
106

PILOT SAMPLE SHOULD BE APPROVED BY A H S P BEFORE BULK PRODUCTION.

		EST. WT. (kg) 0.042	TO BE STAMPED OR MARKED WHERE INDICATED THUS # (LETTERS)
		ALL SHARP EDGES AND CORNERS TO BE REMOVED UNLESS OTHERWISE STATED MACHINED CORNERS TO HAVE R OUT- SIDE R INSIDE EQUIVALENT CHAMFERS ARE PERMISSIBLE.	
		MATERIAL :- =	USED ON :- C5 17.3740.000
ISSUE DATE	NATURE OF AMENDMENTS	CONTROLLERATE OF QUALITY ASSURANCE (HEAVY VEHICLES) AVADI	
DRN	SCALE :- 1:1	TITLE :- GLOW PLUG	
CHD	DIMENSIONS IN mm		
APPD	TOLERANCE ON DIMENSIONS UNLESS OTHERWISE STATED IS : 2102 - 69	D S CAT NUMBER	
DATE	ALL THREADS TO CONFORM TO		
09.5.07		DRAWING NUMBER 17.3740.000ГЧ	
SIZE A4			