

M 4001

NOTES:

1. FINISH $\sqrt{32}$ EXCEPT AS NOTED.
2. BREAK EDGES 0.076 +0.304 UNLESS OTHERWISE SPECIFIED.
3. HEAT TREATMENT: HEAT AT 838FD 860° C. OIL QUENCH TEMPER FOR ONE HOUR MINIMUM TO HARDNESS SPECIFIED (RH C45-51).
4. FINAL PROTECTIVE FINISH 5.3.1.2 OR 5.3.2.2 OF MIL-STD-171.
5. ASME Y14.5M-1994 APPLIES.
6. MATERIAL: STEEL, ASTM A322 DR A331, 4140, 4340.

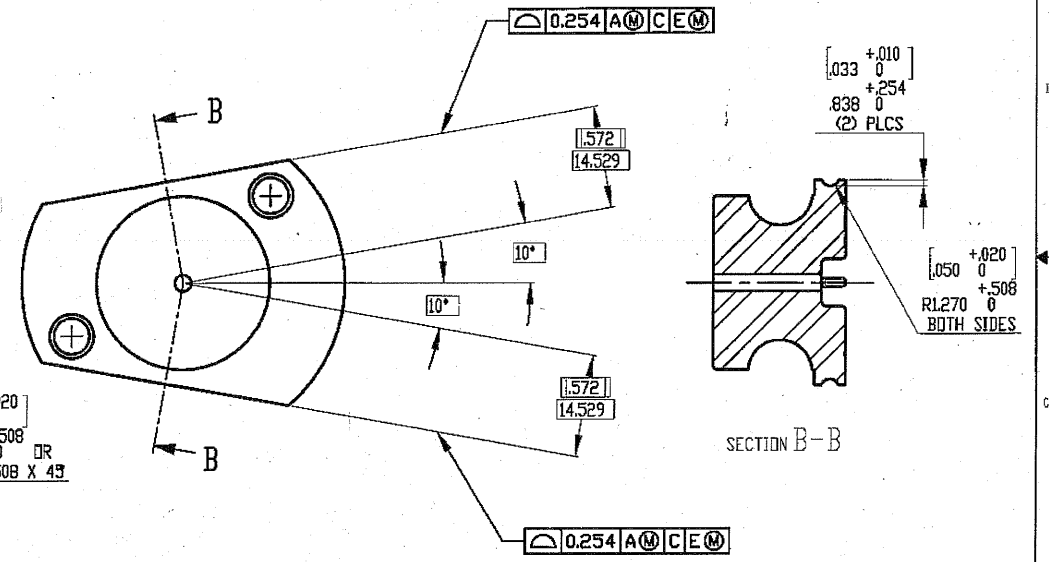
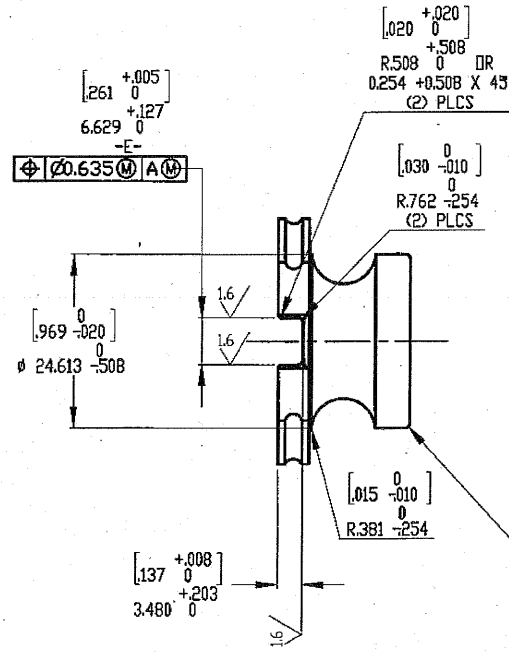
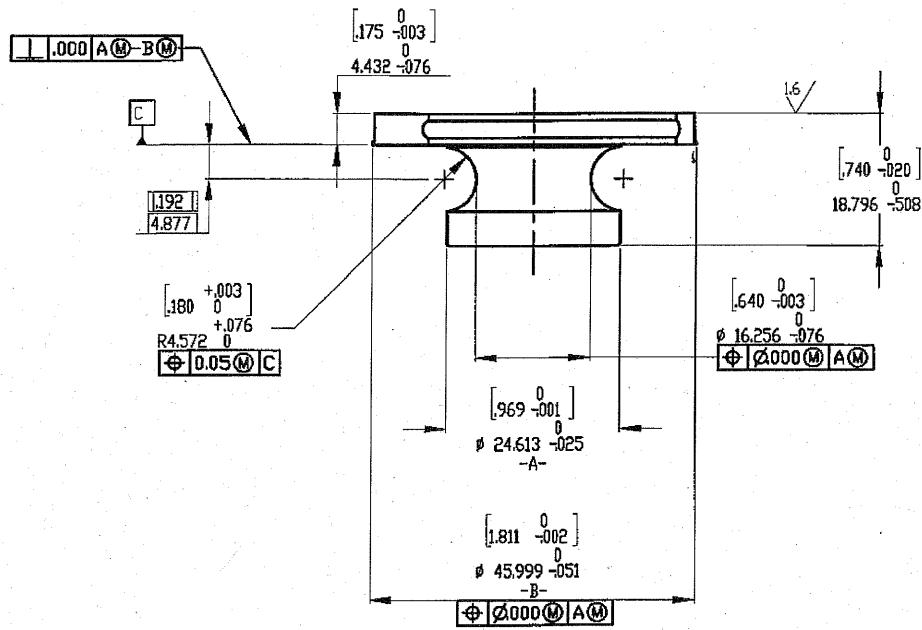
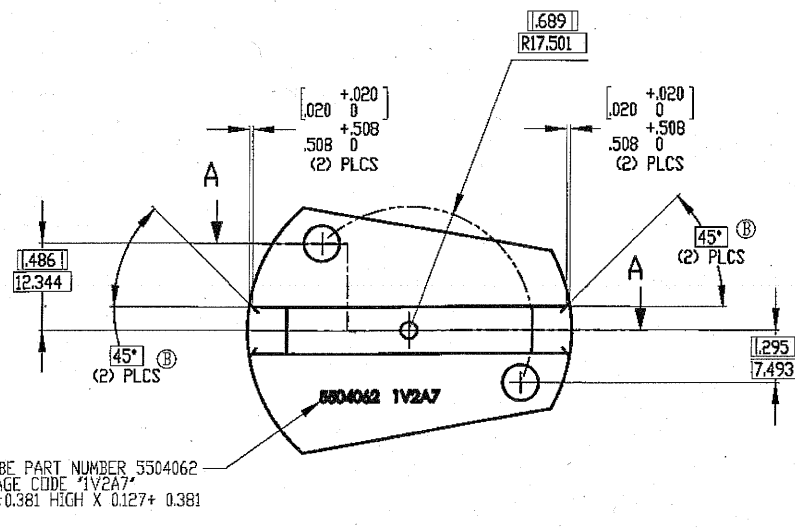
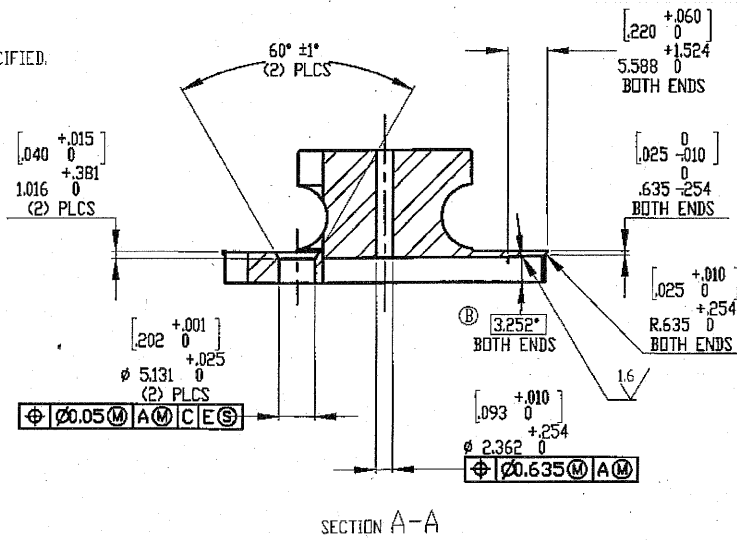

REVISIONS				
ZONE	REV.	DESCRIPTION	DATE	APPROVED
	A	CREATE DRAWING	3/23/2016	G. HERSHBERGER
37, 35, 36	B	UPDATED DIMENSIONS TO CURRENT DIM STANDARDS	3/1/2017	G. HERSHBERGER

UN CONTROLLED COPY
 CERTIFIED CORRECT COPY OF APPROVED
 DRAWINGS AT THIS DATE 29.09.2021
 DESIGN & DRAWING OFFICE,
 ORDNANCE FACTORY, TIRUCHIRAPPALI -620 016.

अप्रतिबद्ध रूप से प्रमाणित
 Provisionally Approved
 24 AUG 2021
 दिनांक हस्ताक्षर/Sig
 for C mde (AP1)

ITAR CONTROLLED		UNLESS OTHERWISE SPECIFIED		NAME	DATE	DHIO ORDNANCE WORKS, INC.
THIS DOCUMENT IS CONTROLLED	EXCEPT WHERE SHOWN OTHERWISE ALL DIMENSIONS ARE IN INCHES	FRAC TIONS	DRAWN	PRD	02/06/16	
THIS DOCUMENT IS CONTROLLED EXCEPT WHERE SHOWN OTHERWISE ALL DIMENSIONS ARE IN INCHES	EXCEPT WHERE SHOWN OTHERWISE ALL DIMENSIONS ARE IN INCHES	FRAC TIONS	DRAWN	PRD	02/06/16	SWITCH, BOLT, 00W50BMG
THIS DOCUMENT IS CONTROLLED EXCEPT WHERE SHOWN OTHERWISE ALL DIMENSIONS ARE IN INCHES	EXCEPT WHERE SHOWN OTHERWISE ALL DIMENSIONS ARE IN INCHES	FRAC TIONS	DRAWN	PRD	02/06/16	
THIS DOCUMENT IS CONTROLLED EXCEPT WHERE SHOWN OTHERWISE ALL DIMENSIONS ARE IN INCHES	EXCEPT WHERE SHOWN OTHERWISE ALL DIMENSIONS ARE IN INCHES	FRAC TIONS	DRAWN	PRD	02/06/16	SIZE D 5504062 REV B
THIS DOCUMENT IS CONTROLLED EXCEPT WHERE SHOWN OTHERWISE ALL DIMENSIONS ARE IN INCHES	EXCEPT WHERE SHOWN OTHERWISE ALL DIMENSIONS ARE IN INCHES	FRAC TIONS	DRAWN	PRD	02/06/16	SCALE: 2:1 WEIGHT: SHEET 1 OF 1

D 5504062