

DRG. NO.- **FS-3022**

UN-TOL. DIMENSIONS AS PER MEDIUM CLASS OF IS: 2102.

AMENDMENTS

REV	DATE	DESCRIPTION	SIGN

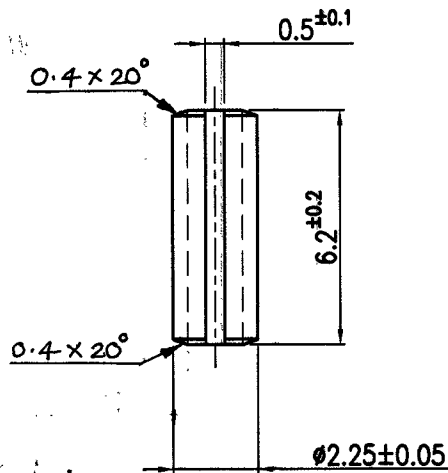
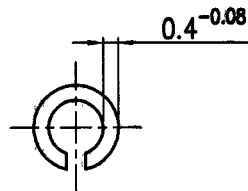

**NOTE:-**

THOUGH THE SURFACE TREATMENT IS NOT BE DONE, SURFACE OF THE COMPONENT SHOULD BE PROPERLY PROTECTED TO AVOID STORAGE & TRANSIT DETERIORATION.

DIMENSIONS ARE IN mm.			MATERIAL- STEEL TO BS.1449 En42E OR En42F		ऑर्डनैस फैक्टरी अम्बाझरी ORDNANCE FACTORY AMBAZHARI
THIRD ANGLE PROJECTION			NOMENCLATURE		
SCALE - 10:1			<b>ROLL PIN</b> (WITHOUT HEAT TREATMENT & SURFACE TREATMENT)		DRG. NO : <b>FS-3022</b>
2018	NAME	DATE			SHEET NO.- 1
DRAWN	रसिका	12/04/18			NO OF SHEETS- 1
CHECKED	<i>[Signature]</i>	12/4/18			OPN.
HOS/CDD	<i>[Signature]</i>	16.4.18			COMPT. ROLL PIN (DET 17)
JWM/FS	<i>[Signature]</i>	12/4/18	M/C:		
APVD:	DGM/FS	<i>[Signature]</i>	15/4/18	STORE:	
				68MM ARDE 1135	