

41979

7490305401

THE DOCUMENT AND THE INFORMATION CONTAINED IN IT ARE PROPRIETARY AND CONFIDENTIAL TO OFI. NO PERSON OR ENTITY IS ALLOWED TO COPY, REPRODUCE OR PUBLISH ANY PART OF THIS DOCUMENT, NOR DISCLOSE ITS CONTENTS TO OTHERS, NOR MAKE ANY USE OF IT, NOR ALLOW OR ASSIST OTHERS TO MAKE ANY USE OF IT UNLESS BY THE PRIOR WRITTEN EXPRESS AUTHORIZATION OF OFI AND THEN ONLY TO THE EXTENT AUTHORIZED.
COPYRIGHT-OFI.

UN CONTROLLED COPY

CERTIFIED CORRECT COPY
OF APPROVED DRAWINGS
AT THIS DATE 15.12.2020

Design & Drawing Office
Ordnance Factory,
Tiruchirappalli-620016

SHEET REV STATUS
ALL SHEETS ARE THE
SAME REVISION

Dwg		Sh		1	
REV	ECO	DESCRIPTION	DATE	APVD	
01		Freeze	15-Sep-13		
02	0022100	Freeze	11-May-14	L.Goldstein	
03		Freeze	09-Jun-14	A.Mansury	
-		Released	01-Jul-14	L.Goldstein	
A-	000000	Released	25-Jun-15	D.Nave	

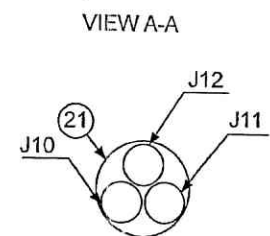
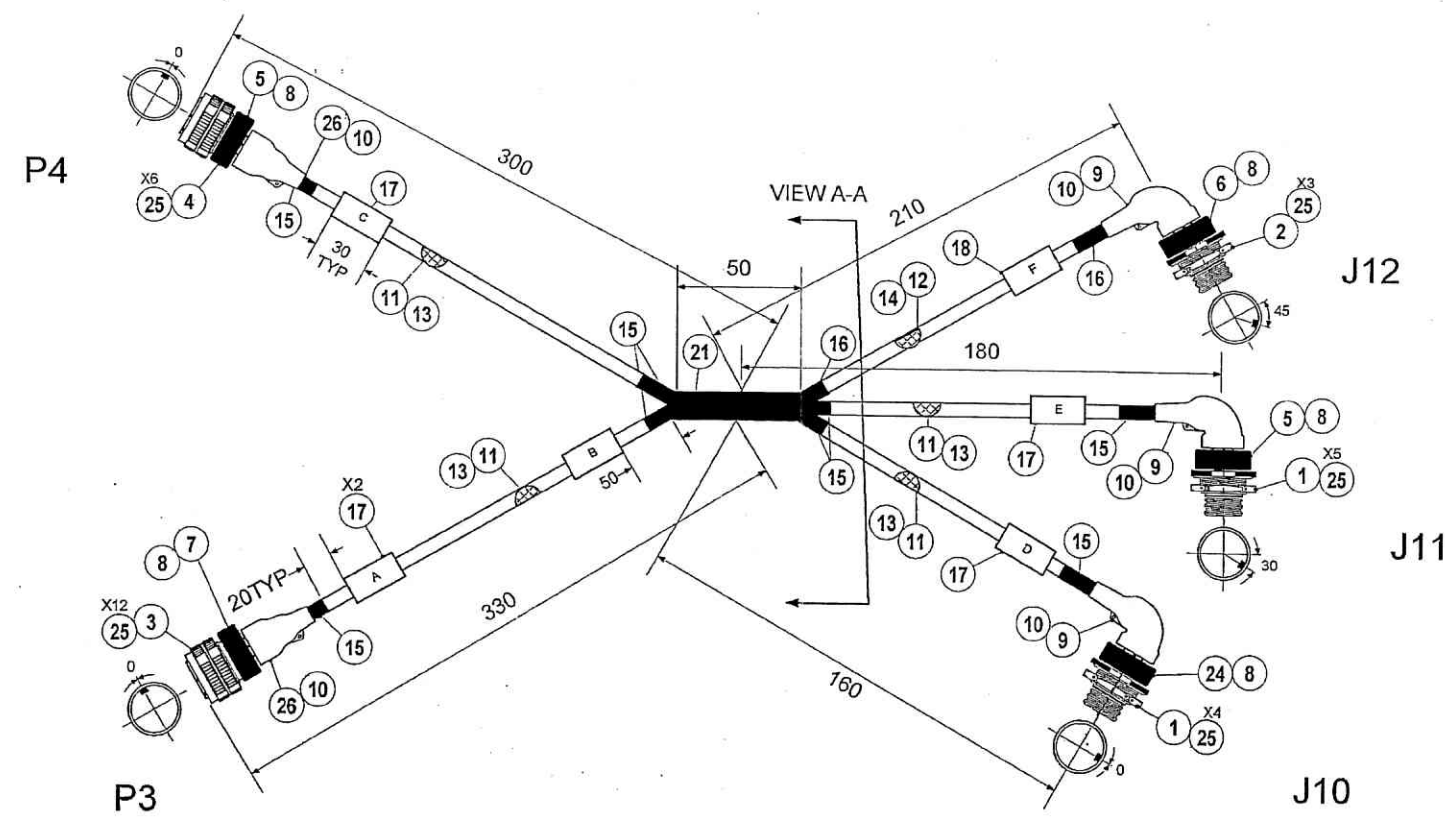

NOTES:
1. MANUFACTURING ACCORDING TO ELBIT 03711A-00

STAMPING REQUIREMENTS:

A	B	C	D	E	F
WPKS4_P3 TO EMU_J3	ELBIT WPKS4 077230A-XX S/N MM/YY__REV__	WPKS4_P4 TO EMU_J4	WPKS4_J10 TO TRV MOT	WPKS4_J11 TO ELV MOT	WPKS4_J12 TO WPKS7_P12

UNLESS OTHERWISE SPECIFIED DIMENSIONS ARE IN MM PER ASME Y14.5M - 1994		SIGNATURE	DATE	ORDNANCE FACTORY TIRUCHIRAPPALLI
TOLERANCES LINEAR	ANGULAR	CHECKED		
3rd. ANGLE PROJECTION		HCS/DDO		TITLE CABLE ASSY, WPKS4
PROJECT OFFICER	OFFICER/PRODN	OFFICER/QC	OFFICER/DDO	FOR: PEDESTAL ASSY OF: 12.7MM SRCG
SURFACE TEXTURE IN Micro INCH		SIZE D	Cage Code SD592	DWG NO 077230A-00
		SCALE 1:1		SHEET 1 OF 2

SEE SEPARATE PARTS LIST

THIS DOCUMENT AND THE INFORMATION CONTAINED IN IT ARE PROPRIETARY AND CONFIDENTIAL TO OFT. NO PERSON OR ENTITY IS ALLOWED TO COPY, REPRINT, REPRODUCE OR PUBLISH ANY PART OF THIS DOCUMENT, NOR DISCLOSE ITS CONTENTS TO OTHERS, NOR MAKE ANY USE OF IT, NOR ALLOW OR ASSIST OTHERS TO MAKE ANY USE OF IT UNLESS BY THE PRIOR WRITTEN EXPRESS AUTHORIZATION OF OFT AND THEN ONLY TO THE EXTENT AUTHORIZED. COPYRIGHT-OFT.

WPKS4

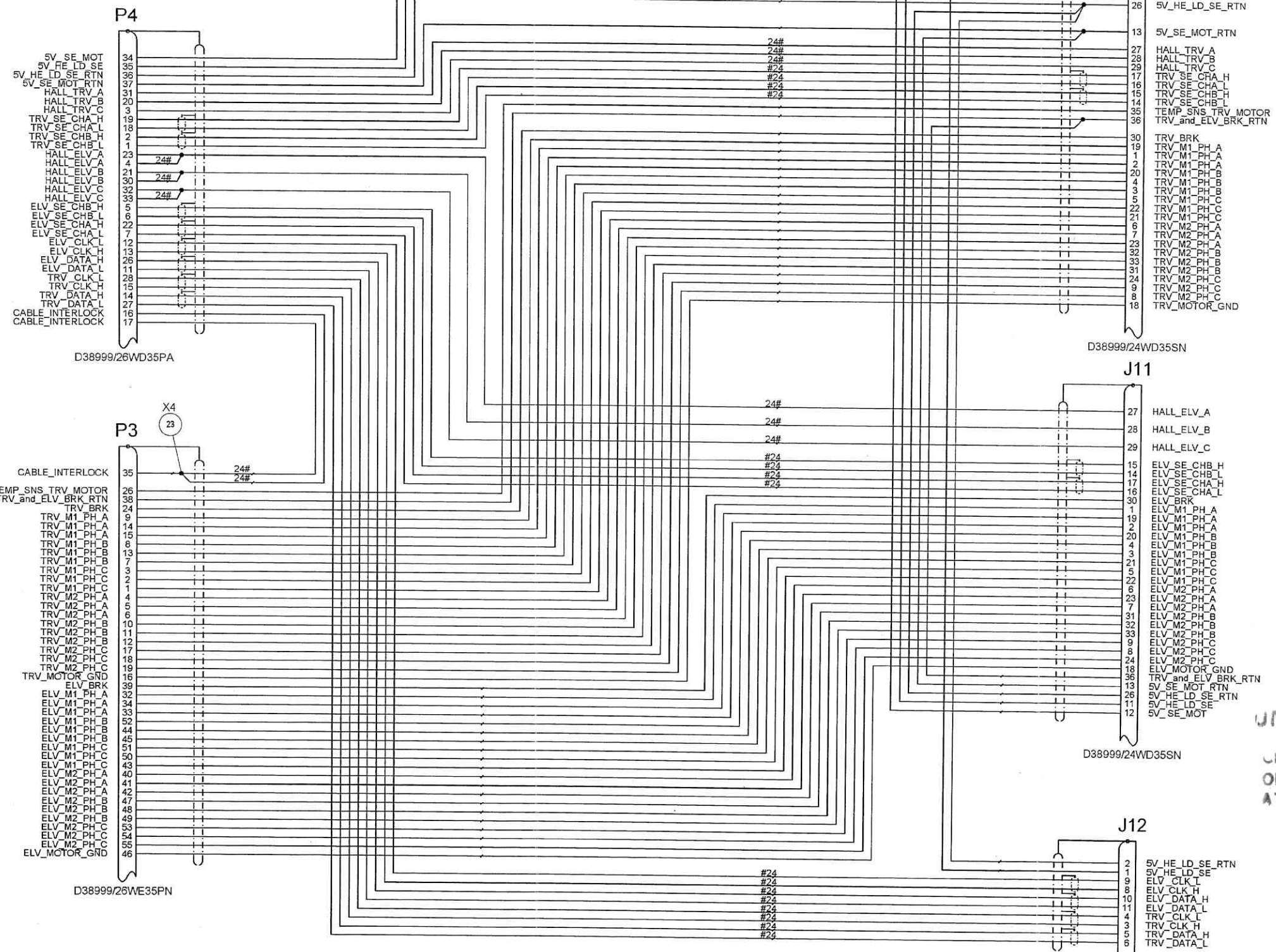

NOTE:
2. ALL WIRE ARE 22AWG UNLESS OTHERWISE SPECIFIED.

UN CONTROLLED COPY
CERTIFIED CORRECT COPY
OF APPROVED DRAWINGS
AT THIS DATE 15-12-2020

Design & Drawing Office
Ordnance Factory,
Machirannalli-520016

SIZE	CAGE CODE	DWG NO	REV
D	SD592	077230A-00	A-
SCALE 1:1		SHEET 2 OF 2	

OFT

ASSEMBLY PARTS LIST

Assembly Parts List For: 077230A-00 Rev: A-

Status: Released Description: CABLE ASSY, WPKS4

FN	CMD	PART NUM	ECO	DESCRIPTION	MB	QTY	U\M	REF. DES./REMARKS	MFG. PN / CUSTOMER	LA	LI
1	PO	99930156M (99930156M)		RECEPT CIRC 37 S NO.15 J/N	P	2	Each	J10,J11	D38999/24WD35SN (More) - 112063670		
2	PO	99933384M (99933384M)		RECEPT CIRC 13 S NO.11 J/N	P	1	Each	J12	D38999/24WB35SN (More)		
3	PO	99933381M (99933381M)		PLUG CIRC 55P NO.17	P	1	Each	P3	D38999/26WE35PN (More) - 112060967		
4	PO	99933376M (99933376M)		PLUG CIRC 37P NO.15 POL-A	P	1	Each	P4	D38999/26WD35PA (More)		
5	MP	031518D-01		ADAPTER D38999-III-15-03	M	2	Each	FOR P4,J11			
6	MP	031518B-02		ADAPTER D38999-III-11-03	M	1	Each	FOR J12			
7	MP	031518E-02		ADAPTER D38999-III-17-04	M	1	Each	FOR P3			
8	PO	00015525N (00015525N)		BAND CLAMP ID.8 W.120 F/BCKSHL	P	5	Each	BAND	600-057		
9	VW	34334801M (34334801M)		BOOT SHRINK RA 1.12 TO .56	P	3	Each	FOR ,J10,J11,J12	222K132-25 (More) - 112022015		
10	YR	00003356N (00003356N)		ADHESIVE EPOXY POLYAMID KIT FO	P	30	GM		S1125 KIT-8 (More)		
11	VW	99929866M (99929866M)		BRAID TUBE .250ID CU/TIN 53A	P	1.400	MR	J10,J11,P3,P4	A-A-59569R36T0250 (More) - 273693648		
12	VW	99676500M (99676500M)		BRAID TUBE .203ID CU/TIN(.281X	P	0.984	FT	J12	A-A-59569R36T0203 (More)		
13	VW	33342603M (33342603M)		CABLE BRAID POLYAMID 9-14MM BL	P	3.281	FT	CABLE BRAID POLYAMID 9-14MM	RG600/F.66.10SW (More)		
14	VW	33342601M (33342601M)		CABLE BRAID POLYAMID 5-8MM BLK	P	0.984	FT	CABLE BRAID POLYAMID 5-8MM	RG600/F.66.06SW (More)		
15	VW	40687011577 (24534712C)		TUBE SHRINK .500/.250 BLK FLEX	P	15.748	IN		M23053/5-108-0 (More) - 38362550		
16	VW	DELETED_40687002100 (24534710C)		TUBE SHRINK .375/.187 BLK FLEX	P	3.937	IN		M23053/5-107-0 (More) - 1467-0005-17		
17	VW	40687010577 (99963632M)		MARKER SLEEVE 1/2DIAx2.0 WHT	P	5	Each	A,B,C,D,E	TMS-SCE-1K-1/2-2.0-9 (More) - 606100612		
18	VW	40687010477 (99963631M)		MARKER SLEEVE 3/8DIAx2.0 WHT	P	1	Each	F	TMS-SCE-3/8-2.0-9 (More) - 1467-0251-10		
21	VW	34370304M (34370304M)		TUBE SHRINK .940/.320 BLK FLEX	P	0.050	MR		M23053/4-304-0 (More)		
22	VW	99929854M (99929854M)		CRIMP SPLICE .110IN 16-20AWG	P	5	Each		M81824/1-2 (More) - 424010335		
23	VW	99931061M (99931061M)		CRIMP BUTT 26-20AWG 1TO1	P	4	Each		D-436-36 (More) - 424010427		
24	MP	031518D-03		ADAPTER D38999-III-15-05	M	1	Each	FOR J10			
25	PO	40332039977 (99930390M)		PLUG GROMMET SEALING NO.22	P	30	Each		MS27488-22-1 (More) - 20195019		
26	VW	33230310M (33230310M)		BOOT SHRINK STR 1.12 TO .56	P	2	Each	FOR P3,P4	202K132-25-01 (More) - 271461584		
27	YR	22016520877 (99620607M)		TAPE ELECT. TEFLON 0.5IN WIDE	P	39.370	IN		60-0.5IN WIDTH (More) - 317100943		

USE OR DISCLOSURE OF DATA IS SUBJECT TO RESTRICTIONS ON THE TITLE PAGE

UN CONTROLLED COPY
 CERTIFIED CORRECT COPY
 OF APPROVED DRAWINGS
 AT THIS DATE 15-12-2020

Design & Drawing Office
 Ordnance Factory,
 Tiruchirappalli-620016

SHEET 1 OF 2

THIS DOCUMENT AND THE INFORMATION CONTAINED IN IT ARE PROPRIETARY AND CONFIDENTIAL TO OFT. NO PERSON OR ENTITY IS ALLOWED TO COPY, REPRINT, REPRODUCE OR PUBLISH ANY PART OF THIS DOCUMENT, NOR DISCLOSE ITS CONTENTS TO OTHERS, NOR MAKE ANY USE OF IT, NOR ALLOW OR ASSIST OTHERS TO MAKE ANY USE OF IT UNLESS BY THE PRIOR WRITTEN EXPRESS AUTHORIZATION OF OFT AND THEN ONLY TO THE EXTENT AUTHORIZED.
COPYRIGHT-OFT.

SHEET REV STATUS
ALL SHEETS ARE THE SAME REVISION

REVISION RECORD				
REV	ECO	DESCRIPTION	DATE	APVD
01		Freeze	08-Jul-09	M Levin
-		Released	26-Nov-09	A Ben-or
A-	VA103/00	Released	14-Feb-11	D.Nave

- NOTES :
- INTERPRET THIS DRAWING IAW ASME Y14.100M.
 - MATERIAL: ALUM. ROD 6061-T6 PER AMS-QQ-A-225/8.
 - UNLESS OTHERWISE SPECIFIED, UNDEFINED MACHINED FILLET MAX RADII SHALL BE 0.2.
 - DEBURR AND REMOVE SHARP EDGES, APPROX. 0.2X45 Deg.
 - FINISH:
 - ZINC COATING - OVER ELECTROLESS NICKEL.
 - ELECTROLESS NICKEL CLASS 3 GRADE B, 13 MICRON THICK PER MIL-C-26074.
 - ZINC COATING ELECTRODEPOSITED TYPE II ,COLOR BLACK, CLASS 3 (OR SC2), 8 MICRON THICK PER ASTM B 633.
 - QUALITY ASSURANCE PROVISIONS FOR THIS ITEM PER RDMQD00012P.
 - PACKAGING AND PACKING:
THE FINISHED PART SHALL BE PRESERVED AND PACKAGED IN ACCORDANCE WITH MANUFACTURER'S COMMERCIAL PRACTICE.
 - IDENTIFY PER MIL-STD-130 PARA 4.1.B, BY LABELING ITS CONTAINER WITH THE PART NUMBER. CHARACTERS 3.2 MM HIGH.

UN CONTROLLED COPY

CERTIFIED CORRECT COPY
OF APPROVED DRAWINGS
AT THIS DATE 15.12.2020

[Signature]
Design & Drawing Office
Ordnance Factory,
Tiruchirappalli-620016

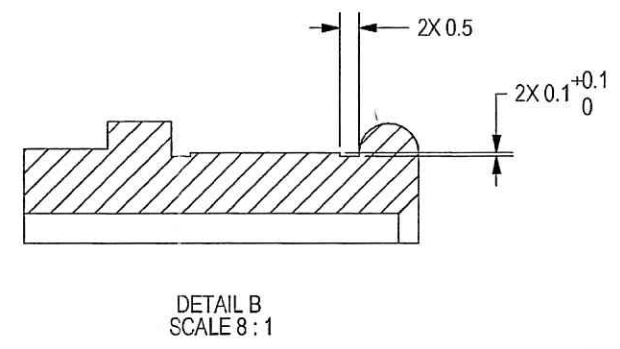
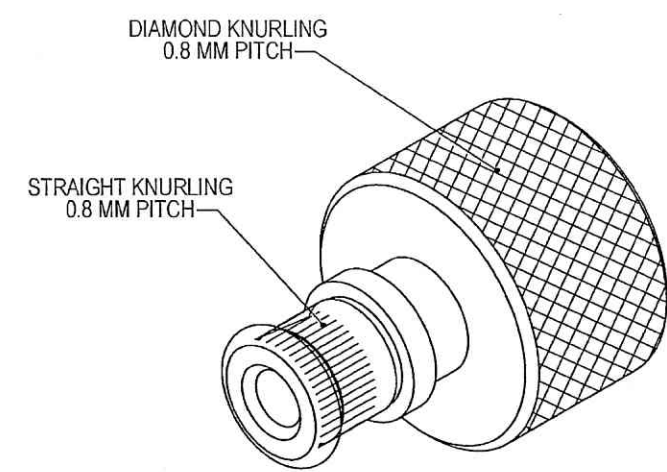
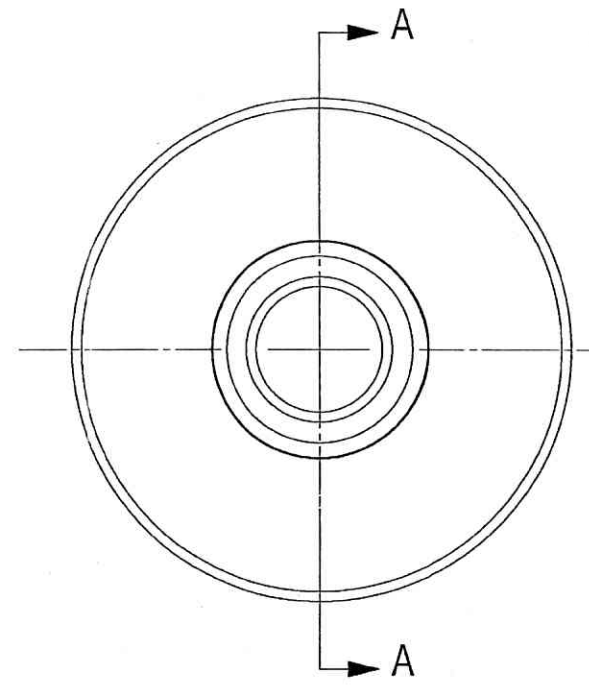
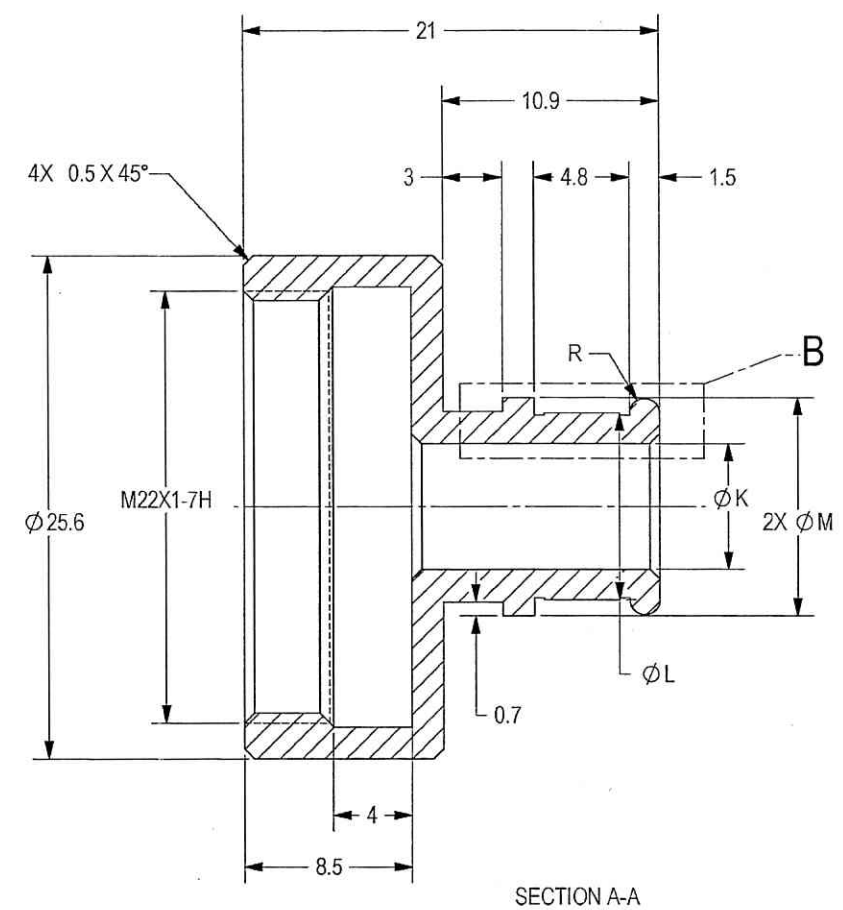

PART NO.	INDENT NO.	K	L	M
031518D-00	D38999-III-15-02	6.4	9.5	11.1
031518D-01	D38999-III-15-03	9.5	12.7	14.3
031518D-02	D38999-III-15-04	12.7	15.9	17.4
031518D-03	D38999-III-15-05	15.9	19.1	20.6

125

SEE ATTACHED MEDIA

UNLESS OTHERWISE SPECIFIED		SIGNATURE	DATE	ORDNANCE FACTORY TIRUCHIRAPPALLI	
DIMENSIONS ARE IN MM PER ASME Y14.5M-1994		DRAWN	11/20/20	TITLE ADAPTER DRAWING, D38999-III-15 FOR: CABLE ASSY, WPKSA OF:12.7MM SRCG	
TOLERANCES LINEAR: ± 0.2 ANGULAR: $\pm 0.5^\circ$		CHECKED	12/10/20		
3rd ANGLE PROJECTION		HOS/DDO	12/10/20	SIZE C	CAGE CODE S0123
SURFACE TEXTURE IN Micro INCH		OFFICER/PRDN		DWG NO 031518D-TB	
		OFFICER/QC		SCALE 4:1	AUTOMATED DRAWING (SW)
		OFFICER/DDO	19/11/20	SHEET 1 OF 1	

THIS DOCUMENT AND THE INFORMATION CONTAINED IN IT ARE PROPRIETARY AND CONFIDENTIAL TO OFT. NO PERSON OR ENTITY IS ALLOWED TO COPY, REPRINT, REPRODUCE OR PUBLISH ANY PART OF THIS DOCUMENT, NOR DISCLOSE ITS CONTENTS TO OTHERS, NOR MAKE ANY USE OF IT, NOR ALLOW OR ASSIST OTHERS TO MAKE ANY USE OF IT UNLESS BY THE PRIOR WRITTEN EXPRESS AUTHORIZATION OF OFT AND THEN ONLY TO THE EXTENT AUTHORIZED. COPYRIGHT-OFT.

SHEET REV STATUS
ALL SHEETS ARE THE SAME REVISION

REVISION RECORD				
REV	ECO	DESCRIPTION	DATE	APVD
01		Freeze	08-Jul-09	M Levin
-		Released	26-Nov-09	A Ben-cr
A-	VA103/00	Released	14-Feb-11	D Nave

NOTES:

- INTERPRET THIS DRAWING IAW ASME Y14.100M.
- MATERIAL: ALUM. ROD 6061-T6 PER AMS-QQ-A-225/8.
- UNLESS OTHERWISE SPECIFIED, UNDEFINED MACHINED FILLET MAX RADII SHALL BE 0.2.
- DEBURR AND REMOVE SHARP EDGES, APPROX. 0.2X45 Deg.
- FINISH:
 - ZINC COATING - OVER ELECTROLESS NICKEL.
 - ELECTROLESS NICKEL CLASS 3 GRADE B, 13 MICRON THICK PER MIL-C-26074.
 - ZINC COATING ELECTRODEPOSITED TYPE II, COLOR BLACK, CLASS 3 (OR SC2), 8 MICRON THICK PER ASTM B 633.
- QUALITY ASSURANCE PROVISIONS FOR THIS ITEM PER RDMQD00012P.
- PACKAGING AND PACKING:
THE FINISHED PART SHALL BE PRESERVED AND PACKAGED IN ACCORDANCE WITH MANUFACTURER'S COMMERCIAL PRACTICE.
- IDENTIFY PER MIL-STD-130 PARA 4.1.B, BY LABELING ITS CONTAINER WITH THE PART NUMBER. CHARACTERS 3.2 MM HIGH.

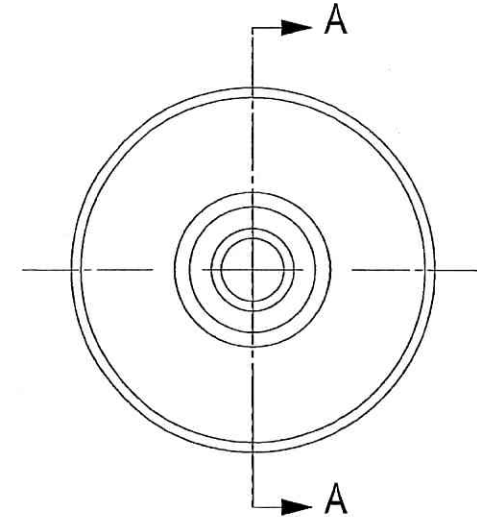
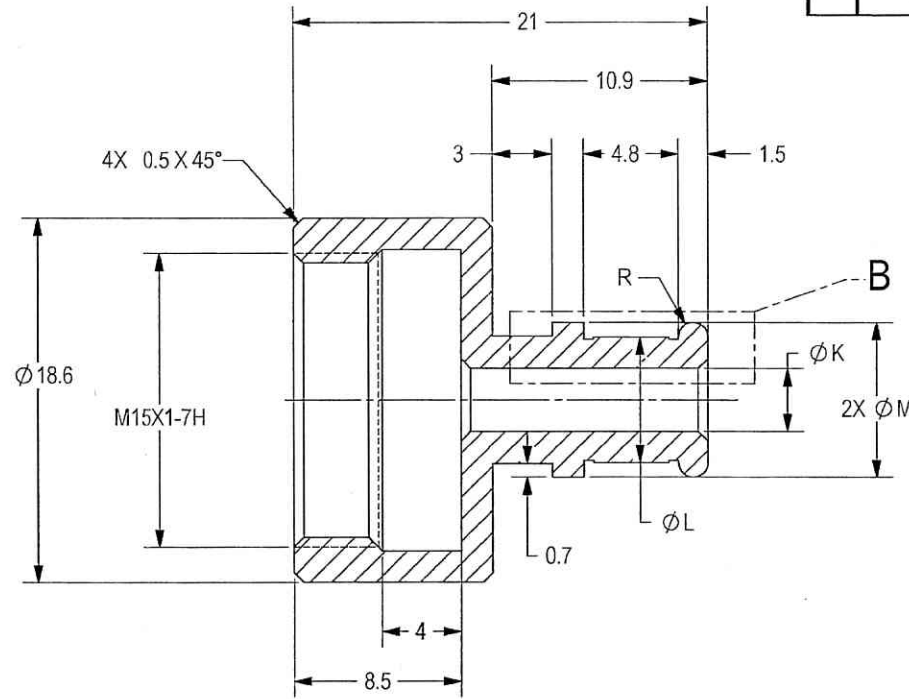

UN CONTROLLED COPY
CERTIFIED CORRECT COPY
OF APPROVED DRAWINGS
AT THIS DATE 15.12.2020

Design & Drawing Office
Ordnance Factory,
Tiruchirappalli-620016

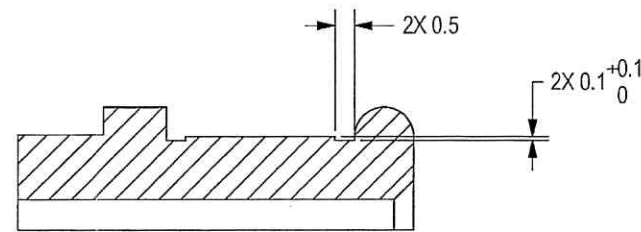
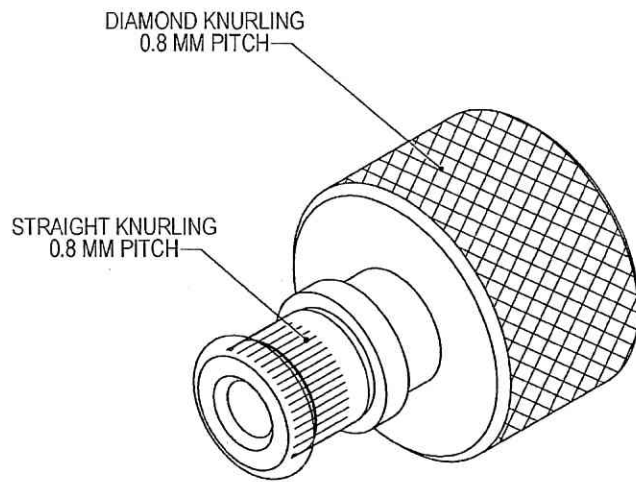

DETAIL B
SCALE 8:1

PART NO.	INDENT NO.	K	L	M
031518B-00	D38999-III-11-01	3.2	6.4	7.9
031518B-01	D38999-III-11-02	6.4	9.5	11.1
031518B-02	D38999-III-11-03	9.5	12.7	14.3
031518B-03	D38999-III-11-04	12.7	15.9	17.4

125

SEE ATTACHED MEDIA

UNLESS OTHERWISE SPECIFIED		SIGNATURE	DATE	ORDNANCE FACTORY TIRUCHIRAPPALLI	
DIMENSIONS ARE IN MM PER ASME Y14.5M-1994		DRAWN	17/12/20	FOR: CABLE ASSY, WPKS 4	
TOLERANCES		CHECKED		TITLE	
LINEAR	ANGULAR	HOS/DDO		ADAPTER DRAWING, D38999-III-11	
±0.2	±0.5°	OFFICER/PRODN		OF: 12.7MM SRCG	
3rd ANGLE PROJECTION		OFFICER/OC		SIZE	CAGE CODE
SURFACE TEXTURE IN Micro INCH		OFFICER/DDO		C	S0123
				DWG NO	031518B-TB
				SCALE	4:1
				AUTOMATED DRAWING (SW)	
				SHEET 1 OF 1	

THIS DOCUMENT AND THE INFORMATION CONTAINED IN IT ARE PROPRIETARY AND CONFIDENTIAL TO OFT. NO PERSON OR ENTITY IS ALLOWED TO COPY, REPRINT, REPRODUCE OR PUBLISH ANY PART OF THIS DOCUMENT, NOR DISCLOSE ITS CONTENTS TO OTHERS, NOR MAKE ANY USE OF IT, NOR ALLOW OR ASSIST OTHERS TO MAKE ANY USE OF IT UNLESS BY THE PRIOR WRITTEN EXPRESS AUTHORIZATION OF OFT AND THEN ONLY TO THE EXTENT AUTHORIZED.
COPYRIGHT-OFT.

SHEET REV STATUS
ALL SHEETS ARE THE SAME REVISION

REVISION RECORD				
REV	ECO	DESCRIPTION	DATE	APVD
01		Freeze	08-Jul-09	M. Levin
-		Released	16-Feb-10	A. Ben-or
A-	VA103/00	Released	14-Feb-11	D. Nave

- NOTES:
- INTERPRET THIS DRAWING IAW ASME Y14.100M.
 - MATERIAL: ALUM. ROD 6061-T6 PER AMS-QQ-A-225/8.
 - UNLESS OTHERWISE SPECIFIED, UNDEFINED MACHINED FILLET MAX RADII SHALL BE 0.2.
 - DEBURR AND REMOVE SHARP EDGES, APPROX. 0.2X45 Deg.
 - FINISH:
 - ZINC COATING - OVER ELECTROLESS NICKEL.
 - ELECTROLESS NICKEL CLASS 3 GRADE B, 13 MICRON THICK PER MIL-C-26074.
 - ZINC COATING ELECTRODEPOSITED TYPE II, COLOR BLACK, CLASS 3 (OR SC2), 8 MICRON THICK PER ASTM B 633.
 - QUALITY ASSURANCE PROVISIONS FOR THIS ITEM PER RDMQD00012P.
 - PACKAGING AND PACKING:
THE FINISHED PART SHALL BE PRESERVED AND PACKAGED IN ACCORDANCE WITH MANUFACTURER'S COMMERCIAL PRACTICE.
 - IDENTIFY PER MIL-STD-130 PARA 4.1.B, BY LABELING ITS CONTAINER WITH THE PART NUMBER. CHARACTERS 3.2 MM HIGH.

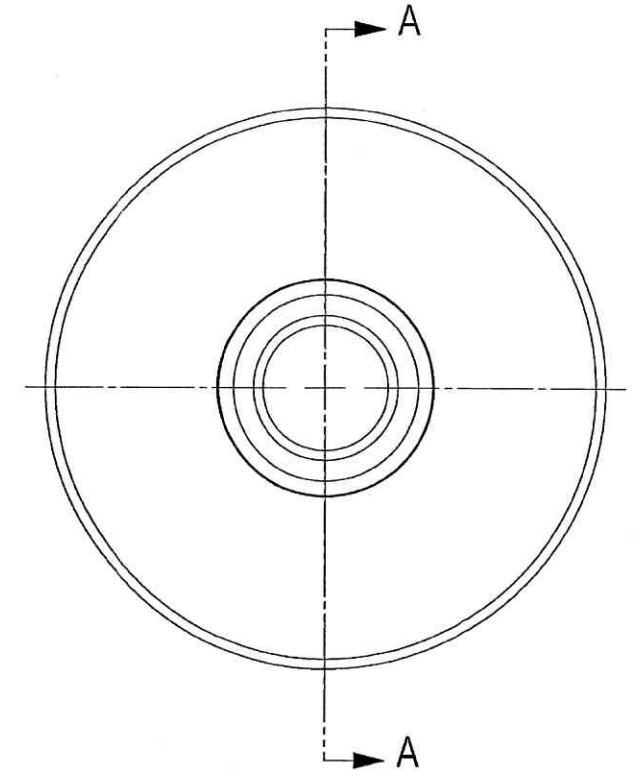
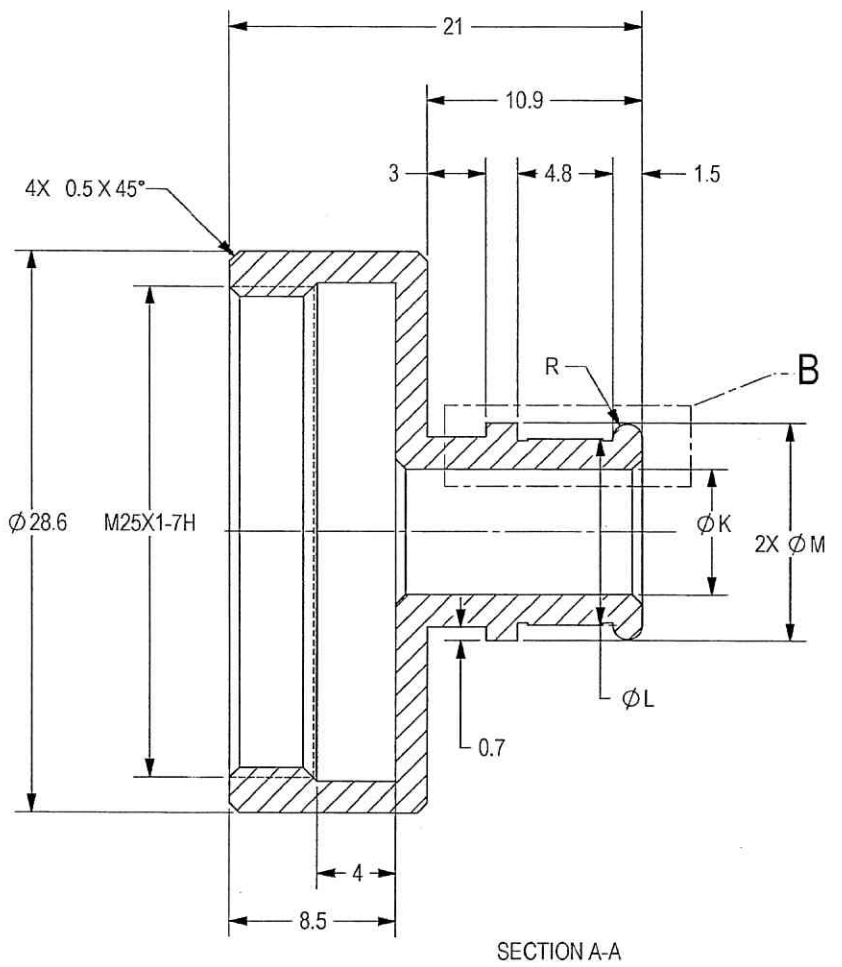

UN CONTROLLED COPY
CERTIFIED CORRECT COPY
OF APPROVED DRAWINGS
AT THIS DATE 15.12.2020
Design & Drawing Office
Ordnance Factory,
Tiruchirappalli-620016

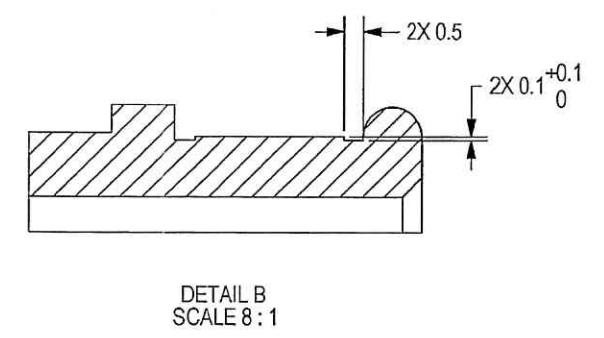
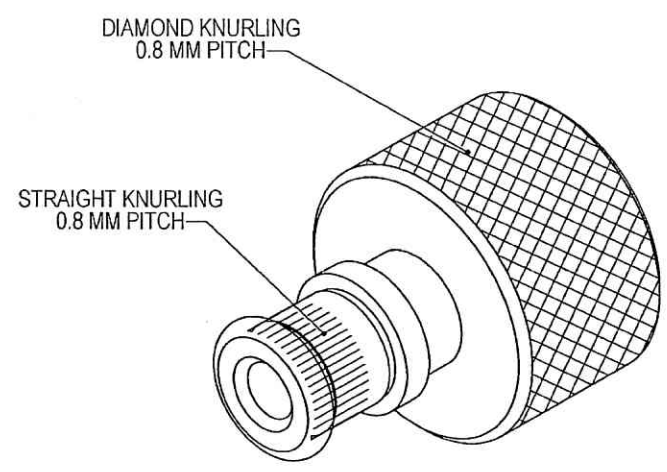

PART NO.	INDENT NO.	K	L	M
031518E-00	D38999-III-17-02	6.4	9.5	11.1
031518E-01	D38999-III-17-03	9.5	12.7	14.3
031518E-02	D38999-III-17-04	12.7	15.9	17.4
031518E-03	D38999-III-17-05	15.9	19.1	20.6

125

SEE ATTACHED MEDIA

UNLESS OTHERWISE SPECIFIED		SIGNATURE		DATE	ORDNANCE FACTORY TIRUCHIRAPPALLI	TITLE ADAPTER DRAWING, D38999-III-17 FOR: CABLE ASSY, WPKS 4 OF: 12.7MM SRCG
DIMENSIONS ARE IN MM PER ASME Y14.5M-1994		DRAWN		17/20		
TOLERANCES		CHECKED			SIZE C S0123 DWG NO 031518E-TB	SCALE 4:1 AUTOMATED DRAWING (SW) SHEET 1 OF 1
LINEAR ±0.2		HOS/DDO		18/01		
ANGULAR ±0.5°		OFFICER/PRODN				
3rd ANGLE PROJECTION		OFFICER/OC				
SURFACE TEXTURE IN Micro INCH		OFFICER/DDO				

THIS DOCUMENT AND THE INFORMATION CONTAINED IN IT ARE PROPRIETARY AND CONFIDENTIAL TO OFT. NO PERSON OR ENTITY IS ALLOWED TO COPY, REPRINT, REPRODUCE OR PUBLISH ANY PART OF THIS DOCUMENT, NOR DISCLOSE ITS CONTENTS TO OTHERS, NOR MAKE ANY USE OF IT, NOR ALLOW OR ASSIST OTHERS TO MAKE ANY USE OF IT UNLESS BY THE PRIOR WRITTEN EXPRESS AUTHORIZATION OF OFT AND THEN ONLY TO THE EXTENT AUTHORIZED.
COPYRIGHT-OFT.

SHEET REV STATUS
ALL SHEETS ARE THE SAME REVISION

REVISION RECORD				
REV	ECO	DESCRIPTION	DATE	APVD
01		Freeze	08-Jul-09	M Levin
-		Released	26-Nov-09	A Ben-or
A-	VA103/00	Released	14-Feb-11	D.Nave

NOTES :

- INTERPRET THIS DRAWING IAW ASME Y14.100M.
- MATERIAL: ALUM. ROD 6061-T6 PER AMS-QQ-A-225/8.
- UNLESS OTHERWISE SPECIFIED, UNDEFINED MACHINED FILLET MAX RADII SHALL BE 0.2.
- DEBURR AND REMOVE SHARP EDGES, APPROX. 0.2X45 Deg.
- FINISH:
 - ZINC COATING - OVER ELECTROLESS NICKEL.
 - ELECTROLESS NICKEL CLASS 3 GRADE B, 13 MICRON THICK PER MIL-C-26074.
 - ZINC COATING ELECTRODEPOSITED TYPE II, COLOR BLACK, CLASS 3 (OR SC2), 8 MICRON THICK PER ASTM B 633.
- QUALITY ASSURANCE PROVISIONS FOR THIS ITEM PER RDMQD00012P.
- PACKAGING AND PACKING:
THE FINISHED PART SHALL BE PRESERVED AND PACKAGED IN ACCORDANCE WITH MANUFACTURER'S COMMERCIAL PRACTICE.
- IDENTIFY PER MIL-STD-130 PARA 4.1.B, BY LABELING ITS CONTAINER WITH THE PART NUMBER. CHARACTERS 3.2 MM HIGH.

UN CONTROLLED COPY
CERTIFIED CORRECT COPY
OF APPROVED DRAWINGS
AT THIS DATE 15.12.2020
Design & Drawing Office
Ordnance Factory,
Tiruchirappalli-620018

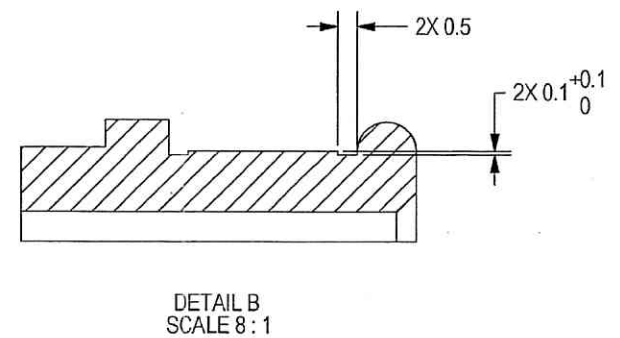
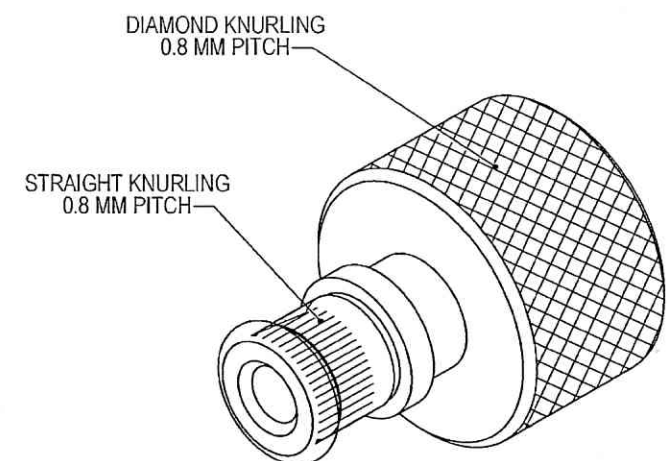
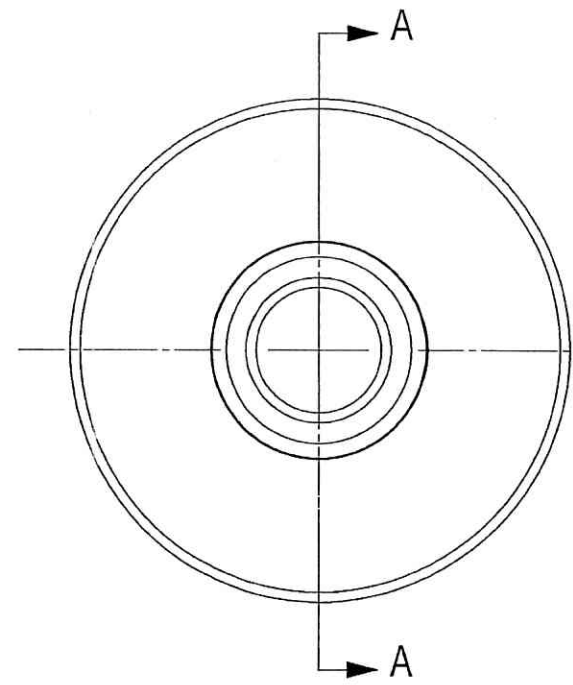
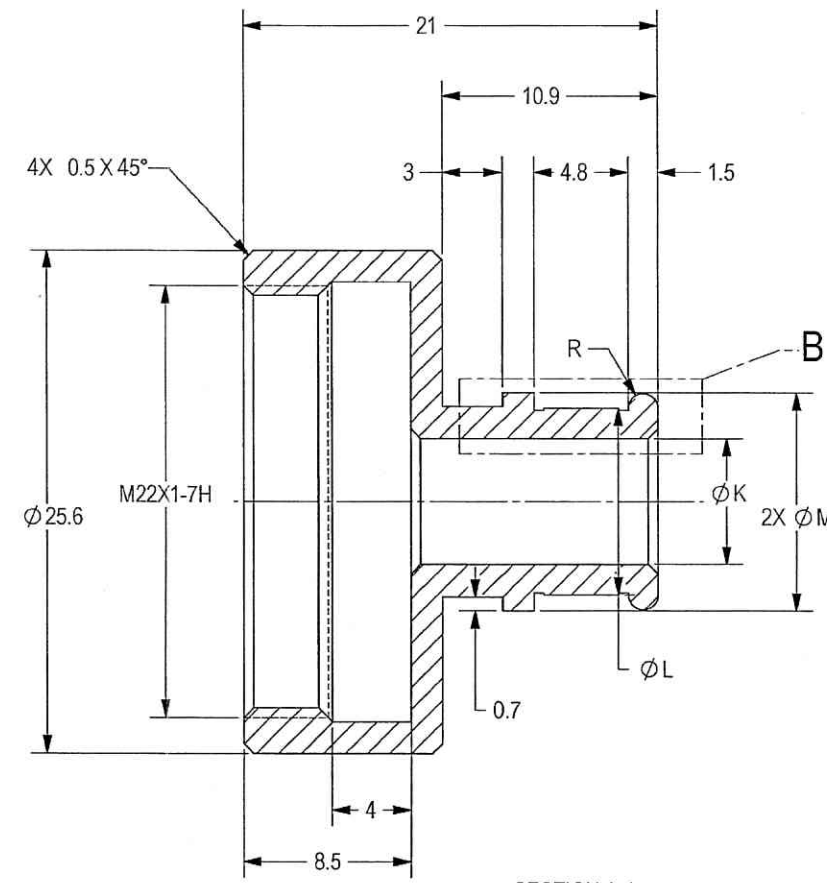

PART NO.	INDENT NO.	K	L	M
031518D-00	D38999-III-15-02	6.4	9.5	11.1
031518D-01	D38999-III-15-03	9.5	12.7	14.3
031518D-02	D38999-III-15-04	12.7	15.9	17.4
031518D-03	D38999-III-15-05	15.9	19.1	20.6

125

SEE ATTACHED MEDIA

UNLESS OTHERWISE SPECIFIED	SIGNATURE	DATE	ORDNANCE FACTORY TIRUCHIRAPPALLI	
DIMENSIONS ARE IN MM PER ASME Y14.5M-1994	DRAWN	17/12/20	FOR: CABLE ASSY, WPK54	
TOLERANCES	CHECKED		TITLE	
LINEAR ±0.2	HOS/DDO	P. 15/2 18/02	ADAPTER DRAWING, D38999-III-15	
ANGULAR ±0.5°	OFFICER/PRODN		OF: 12.7MM SRCG	
3rd ANGLE PROJECTION	OFFICER/OC		SIZE	CAGE CODE
	OFFICER/DDO		C	S0123
			DWG NO	031518D-TB
			SCALE	4:1
			AUTOMATED DRAWING (SW)	
			SHEET 1 OF 1	