

DRAWING NUMBER
175.47.019

SHEET No 1 OF 1

18/00000
 B. JAYAVELU (JT01D)
 25-10-05

"COMMON TO T-90"
 DRG RE-INDIANISED BASED ON RUSSIAN ORIGINAL ISSUE:- 7

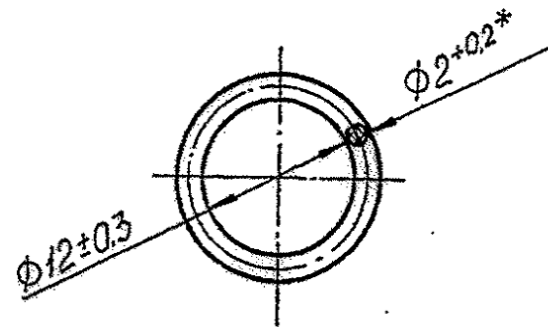

1. ALTERNATE MATERIAL : RUBBER 9831 OR B 14-1 OR 51-3029 TY 005 216-75.
2. DIMENSION NOT MARKED WITH AN ASTERISK * IS ENSURED WITH TOOL
3. SHIFT ALONG MOULD. PARTING LINE NOT EXCEEDING 0.20 mm IS ALLOWED.
4. TO BE MARKED ON TAG.
5. THE REST OF THE REQUIREMENTS - ACCORDING TO SPEC. TY 005 216-75. CODE 25.311 НП.

EXPLANATORY NOTE :-

REFERENCE MATERIAL QUOTED RUBBER УПТ-1078 TY 005 216-75
 REFERENCE NOTE 1 ON ALTERNATIVE MATERIAL RUBBER 9831 OR B 14-1 OR 51-3029 TY 005 216-75.

PHYSICAL AND MECHANICAL PARAMETERS		
RUBBER GRADE	УПТ 1078	9831
TYPE OF RAW RUBBER	CKH-18 CKH-26	CKH-26
RUPTURE STRENGTH Kgf/cm ² MIN.	110	100
ELONGATION OF RUPTURE % MIN.	130	300
RESIDUAL ELONGATION % MAX	6	20
HARDNESS CONVENTIONAL UNITS (TIP)	75 - 85	55 - 70
DENSITY g/cm ³ ± 0.05	1.37	1.18
WORKING TEMPERATURE	- 35° C TO + 125° C	- 35° C TO + 150° C
WORKING MEDIUM	LUBRICANTS, OILS.	LUBRICANTS, OILS.

7B ALT. MATL: RUBBER GRADE N3 TO SPECN. CQA(HV)/NBR

7A 188.45.001cb-3Cb

PILOT SAMPLE SHOULD BE APPROVED BY A H S P BEFORE BULK PRODUCTION

EST WT (Kg) TO BE STAMPED OR MARKED WHERE INDICATED THUS # (LETTERS)
0.0002

ALL SHARP EDGES AND CORNERS TO BE REMOVED UNLESS OTHERWISE STATED MACHINED CORNERS TO HAVE R OUT SIDE R INSIDE EQUIVALENT CHAMFERS ARE PERMISSIBLE

DRN	Sd/=	MATERIAL:- RUBBER УПТ-1078 TY 005 216-75	USED ON:- 172.45.060cbCb 175.45cbCb
CHD	Sd/=	CONTROLLERATE OF QUALITY ASSURANCE (HEAVY VEHICLES) AVADI	
APPD	Sd/=		
DATE	03-12-95	TITLE:- SEALING RING	
SCALE :- 2:1			
DIMENSIONS IN mm		D S CAT NUMBER	
TOLERANCE ON DIMNS UNLESS OTHERWISE STATED IS 2102 69			
7B	13-01-07	DRAWING NUMBER 175.47.019	
7A	25.10.04		
7	07.11.90	N OF A No. CQA(HV)/T90/45/001 172M 627 A, 88 AL 11/2.	
ISSUE	DATE	NATURE OF AMENDMENTS	
ALL THREADS TO CONFORM TO IS: 4218 Pt IV			

F-88
26
SIZE A3