

ORDNANCE FACTORY, DEHRADUN

SIGHT NIGHT VISION PASSIVE 5.56mm, RIFLE (INSAS) CASED 101A

NAME PLATE-II (HINDI & ENG.)

DRG. NO. IRDE-2653/4

THIRD ANGLE PROJECTION

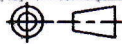

MCT-2548/1

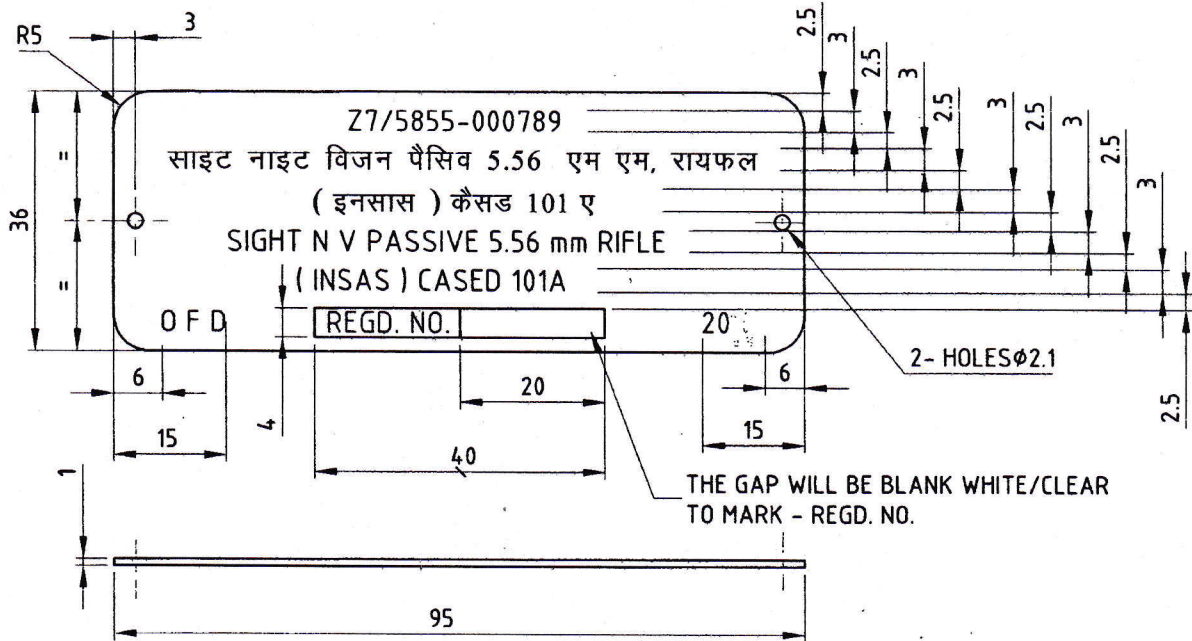

NOTE :-

LETTERS & FIGURES ARE TO BE PHOTOETCHED BLACK ON ANODISED AL. PLATE.

MATL. :-

AL. ALLOY, 19000 HI-IS: 737-1986

FINISH. :-

ANODISED AC-15 IS:1868-1982

FOR TRADE OFF
Date of Issue 12/03/2020
24-

DIMENSIONS ARE IN M/M. OTHERWISE STATED
IMPORTANT DIMENSIONS MARKED THUS ⊗
INFORMATION MARKED THUS † TO BE MARKED ON

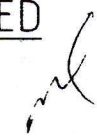
		DT.- 30-08-2007	SCALE- 1:1
	DR- P.C.SINGH	MATL.	TREAT.
	TR-	AS ABOVE	AS ABOVE
	CH-	SHEETS- 1	SHT. NO.- 1
DA.No 27/2011 DT-30/9/11	<p style="text-align: center;">APPROVED</p>   JWM/D.O. Jt.GM/P-II	<u>DRAWING NO.</u>	
AMENDMENTS		<u>MCT- 2548/1</u>	
OFD/DO/002			

CASE CARRYING

DRG. No. **GOGGLES, PASSIVE NIGHT VISION 102 A**
 IRDE-1613/6 **PLATE**

TITLE OF	OPERATION
----------	-----------

THIRD ANGLE PROJECTION

MCT-1644/1

ORDNANCE FACTORY, DEHRADUN.

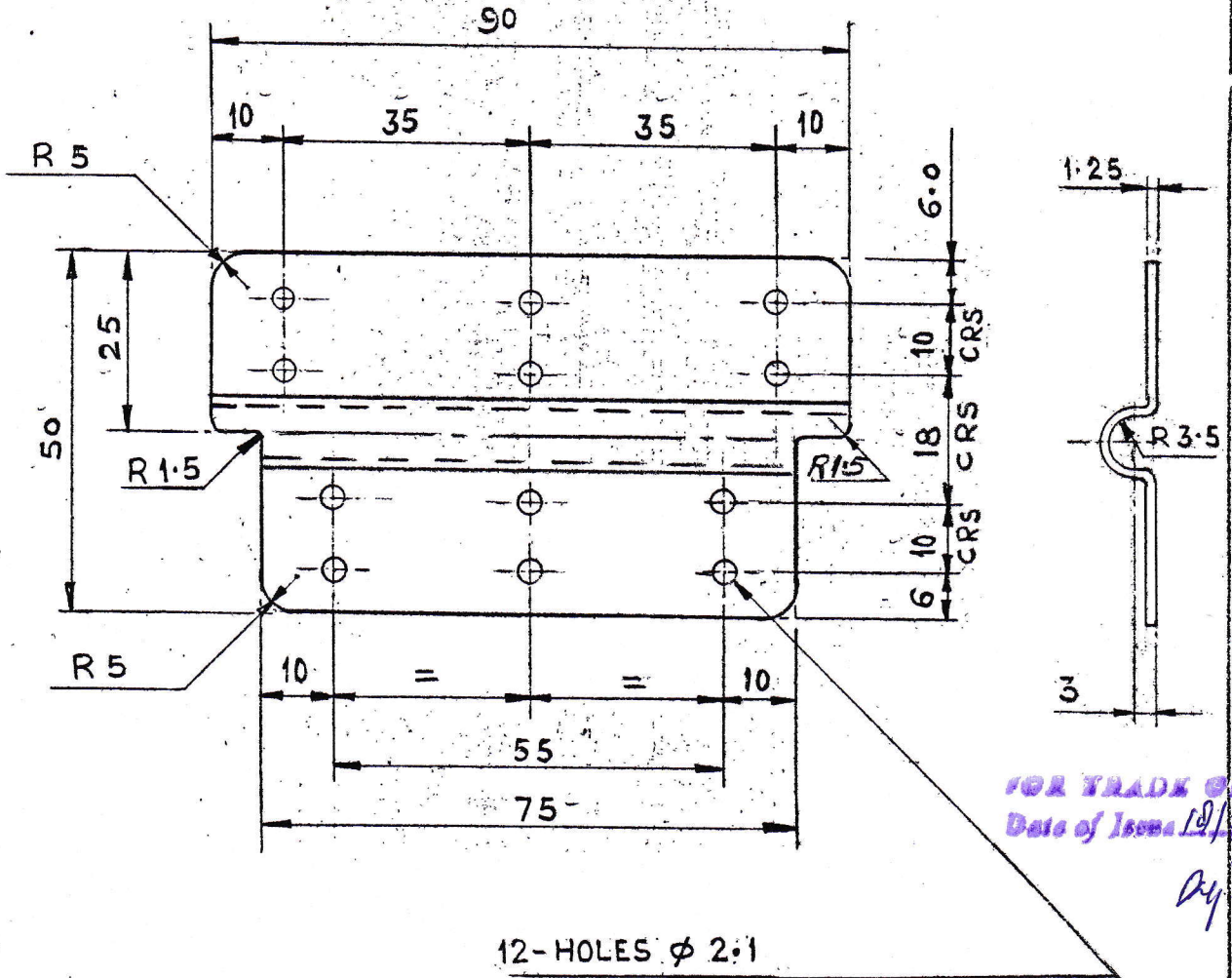

FOR TRADE COPY
 Date of Issue 18/03/2012

dy-

MATL. M.S. IS: 1079 Gde. 0

* FINISH:- APPLY PRIMER TO IS: 2074-1962 & THEN PENTED (ISC 294 TO IS: 5-1978) OF IS: 8982-1978 EXCEPT BEARING-SURFACE.

DIMENSIONS ARE IN M/M

IMPORTANT DIMENSIONS MARKED THUS ⊕

INFORMATION MARKED THUS TO BE MARKED ON

	DR- <i>Standard</i>	D/- 9-4-99	SCALE: 1:1
	TR-	MATL. AS ABOVE	TREAT -
	CH- <i>MS</i>	SHEETS 1	SHEET No. 1
* D.A.No. 12/2012 DT. 13.9.2012.	APPROVED	DRAWING No.	
AMENDMENTS	<i>JWM</i>	MCT/1644/1	
OFD/DO/002	JWM/DO WM/MIS		

CASE CARRYING GOGGLES. N.V.P. 102A.

DRG NO IRDE-379/9 HOOK

CAT./PT. No 5340-002A2A

TITLE OF

OPERATION

THIRD ANGLE PROJECTION



ORDNANCE FACTORY, DEHRADUN

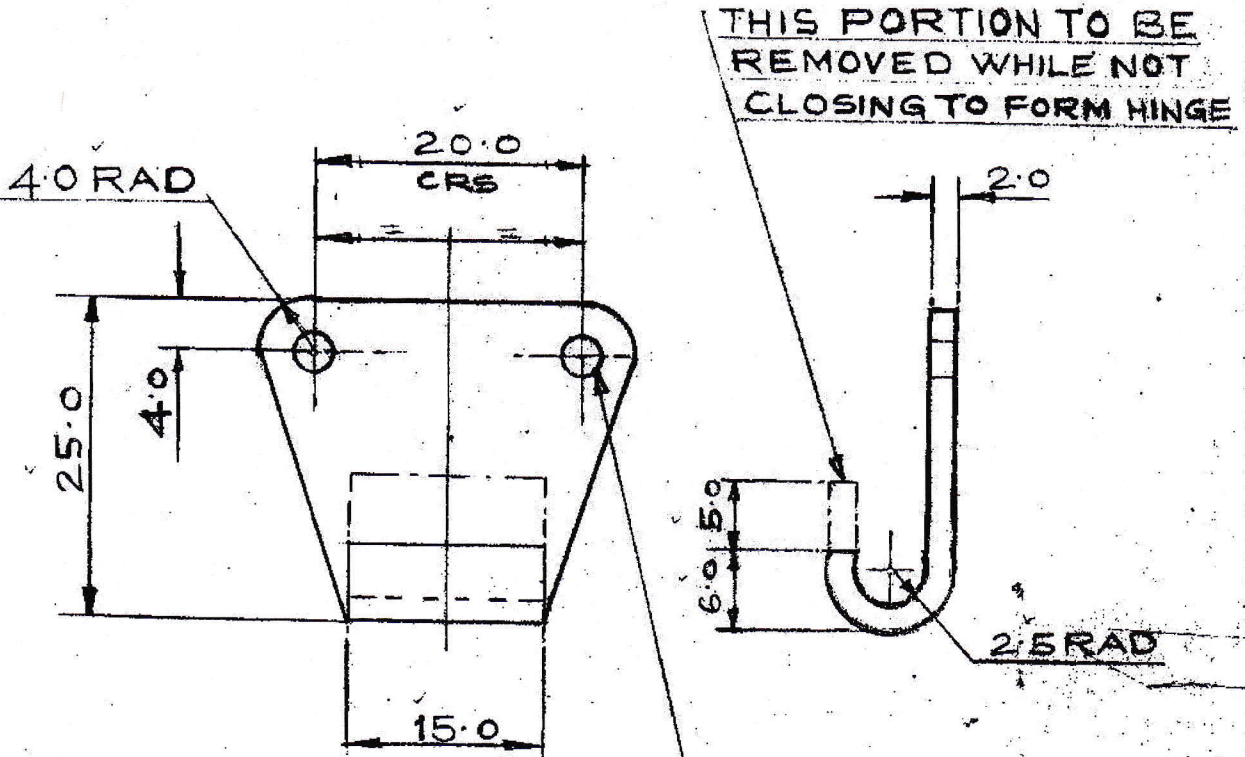

2-HOLES, TO SUIT 2.5 DIA. RIVET.

FOR TRADE ONLY
Date of Issue 10/03/20
Rdf

MATL: - CARBON STEEL, SHEET, DEEP DRAWING,
IS: 513-1986.

✓ FINISH:- APPLY PRIMER TO IS: 2074-1962 AND THAN
* PAINTED (ISC-294 TO IS: 5-1978) OF IS: 8982
- 1978 EXCEPT BEARING SURFACES.

	DR- SKThapliya	D/6-4-99	SCALE 2:1
	TR-	MATL.	TREAT.
	CH- Rishi	AS ABOVE	-
		SHEETS 1	SHEET No. 1
* D.A. No 18/2002 DE-08-8-2002	APPROVED	DRAWING NO.-	
O.F.D/D0/002	(Signature) WJM/DO	MCT- 1636/1	
AMENDMENTS	(Signature) WM/MIS		

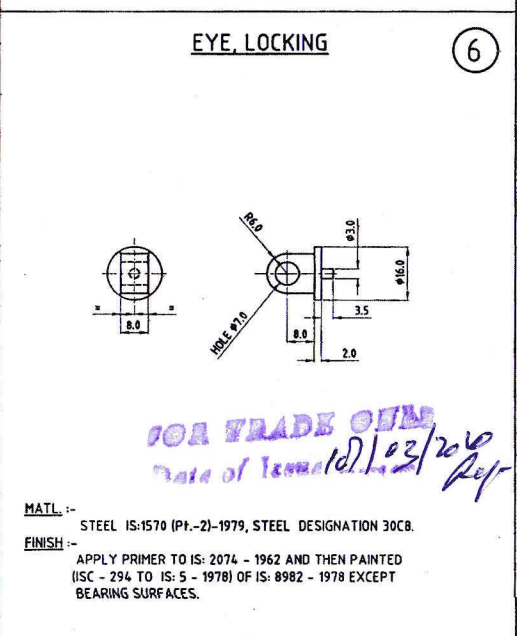
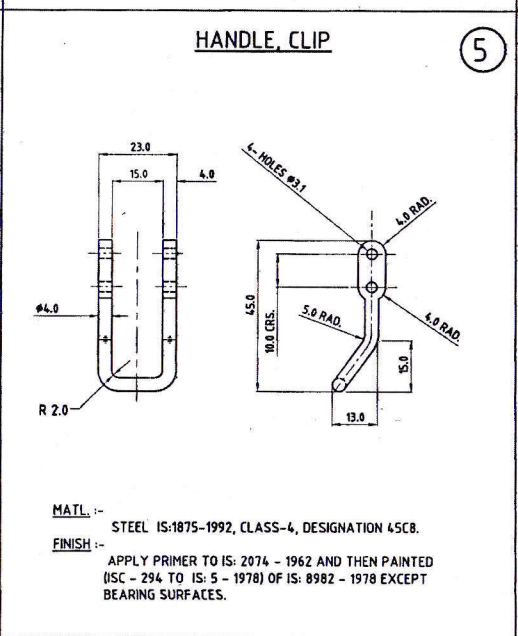
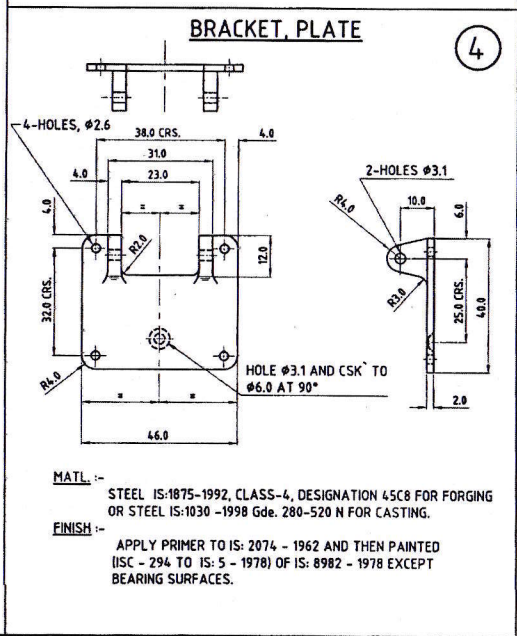
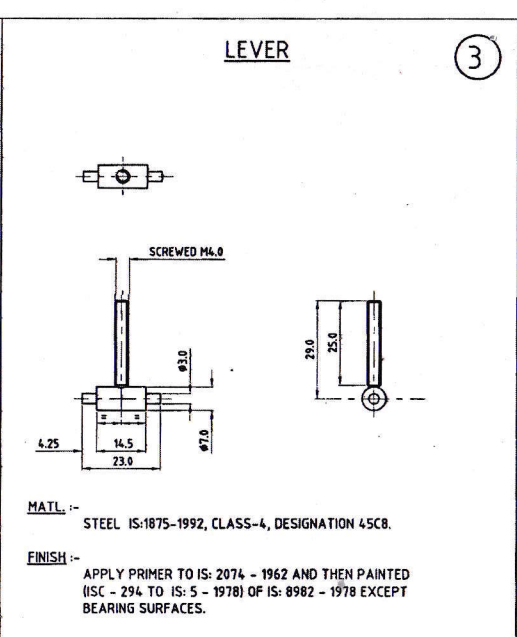
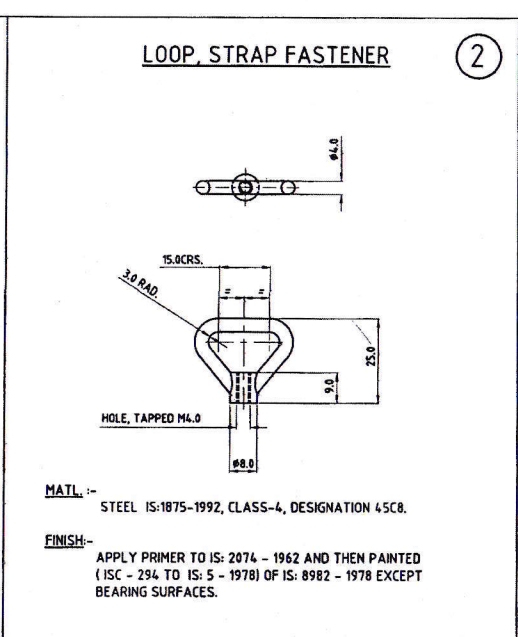
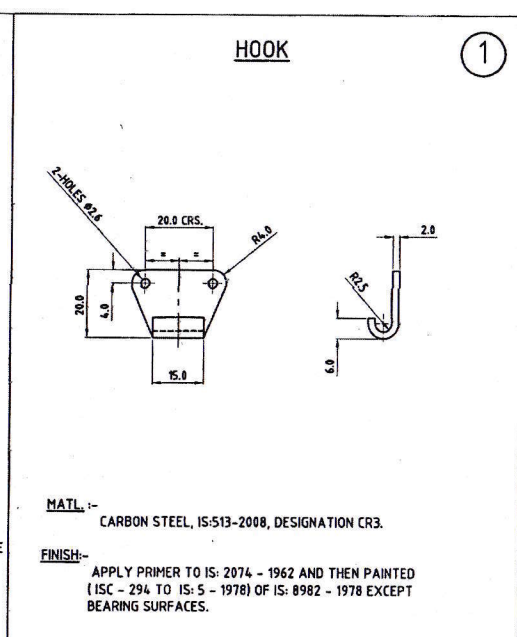
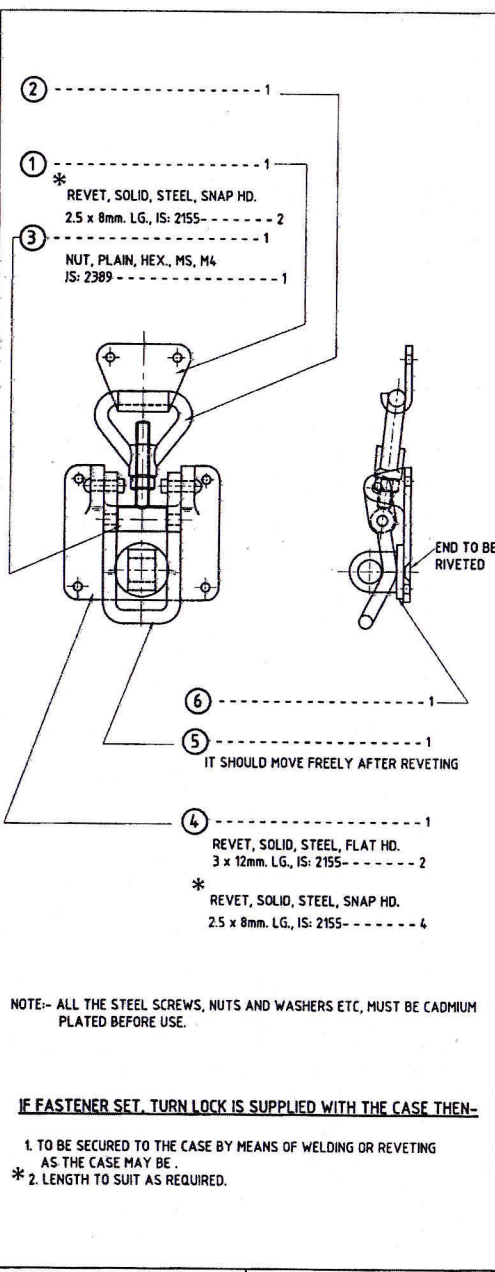

ORDNANCE FACTORY
 DEHRADUN

MADE BY: P.C.SINGH

TR-

CHECKED BY:

APPROVED

[K.Saini]
 JWM/DO.

[T.Khattar]
 DGM/P

CASE CARRYING, GOGGLES NIGHT VISION, PASSIVE, 102 A

FASTENER SET, TURN LOCK

(ASSY. DRG.)

REF.DRG.NO.
 IRDE-328

	DT.- 11.02.15	SCALE- NTS
	MATL. AS ABOVE	TREAT. AS ABOVE
D.A.No.-28/2018, DT.-30/11/2018		
D.A.No.-14/2015 DT.- 11/02/2015	SHEETS. 1	SHT. NO. 1
AMENDMENTS	DRAWING NO.	
OFD/DO/002	MCT-1617/1	

CASE CARRYING, FRP OF P.N.S. FOR
84 mm. CARL GUSTAV GUN
CLIP, RETAINING

DRG. No.-
 IRDE-2613/8

MCT-1369

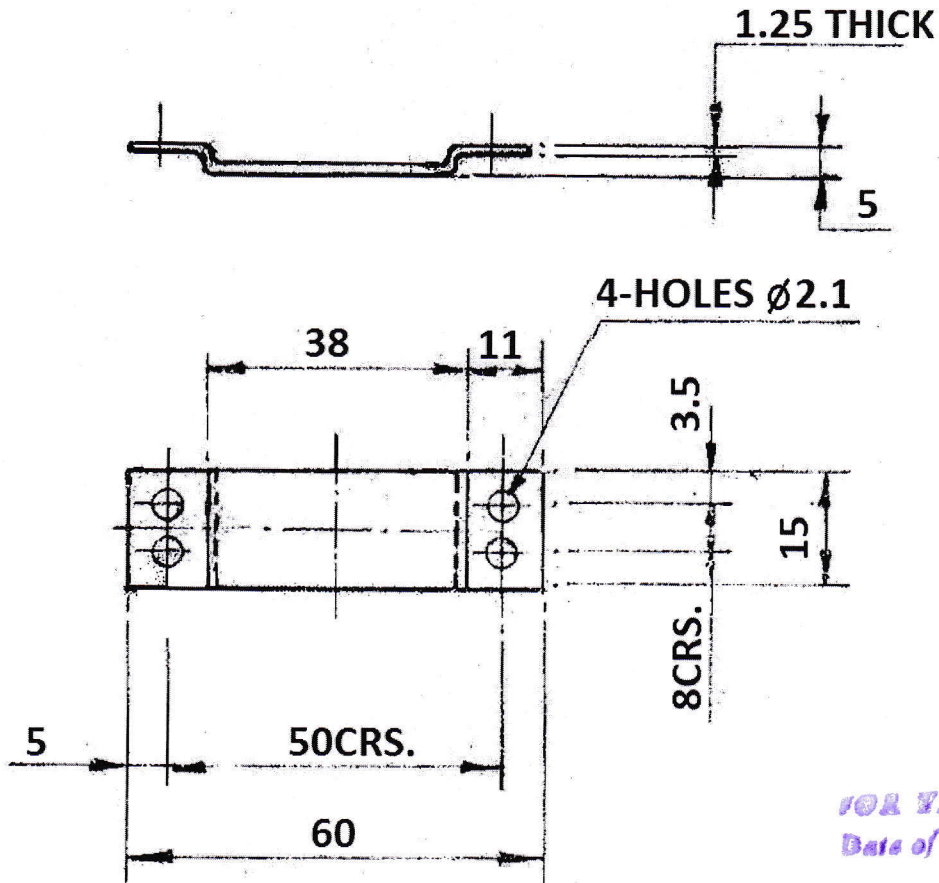

FOR TRADE CHM
 Date of Issue 12/03/2018
 Ref

MATL.- STEEL Gde-HR1 TO IS:1079-2017.

FINISH :- APPLY PRIMER TO IS:2074-1962 AND THEN PAINTED
 (ISC 294 TO IS:5-1978) OF IS:8982-1978 EXCEPT
 BEARING SURFACES.

ALL DIMENSIONS ARE IN mm.

		DT.-18-4-95	SCALE- 1:1
		<u>MATL.</u> AS ABOVE	<u>FINISH</u> AS ABOVE
		SHEETS- 1	SHEET No.- 1
		<u>DRAWING No.-</u>	
		<u>MCT-1369</u>	
D.A. NO.- 30/2018, DT.- 08/12/2018	DR - <i>m...</i>	APPROVED <i>[Signature]</i> M.L. Temg AWM/PL-2	
AMENDMENTS	TR -		
OFD/DO/002	CH - <i>R...</i>		

ODRNRANCE FACTORY, DEHRADUN