

M.1326

REVISIONS				
ZONE	REV.	DESCRIPTION	DATE	APPROVED
	A	CREATE DRAWING	2/12/2008	J. HERSHBERGER

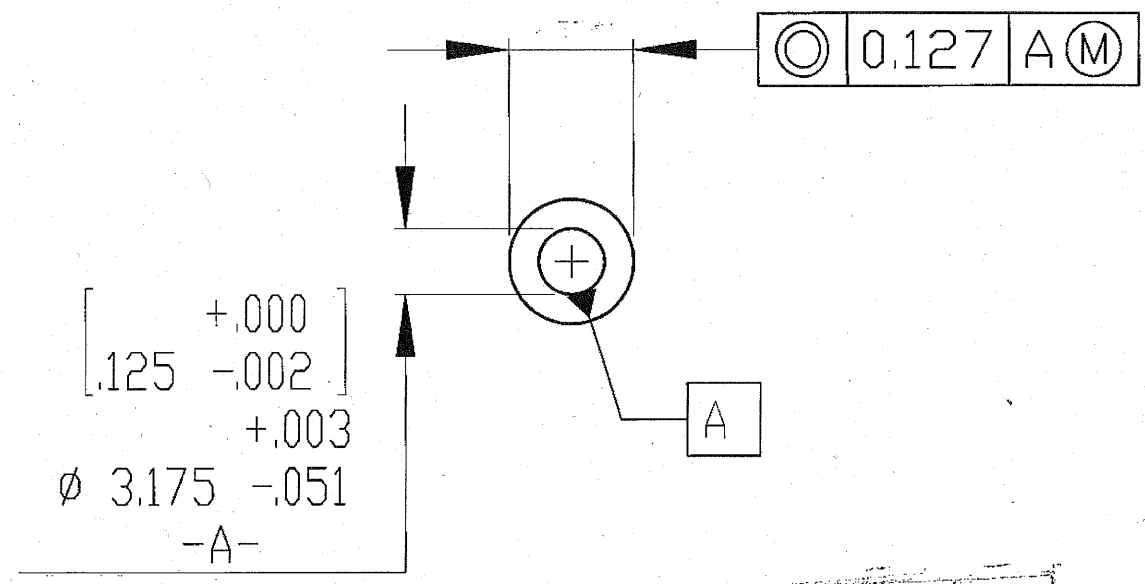
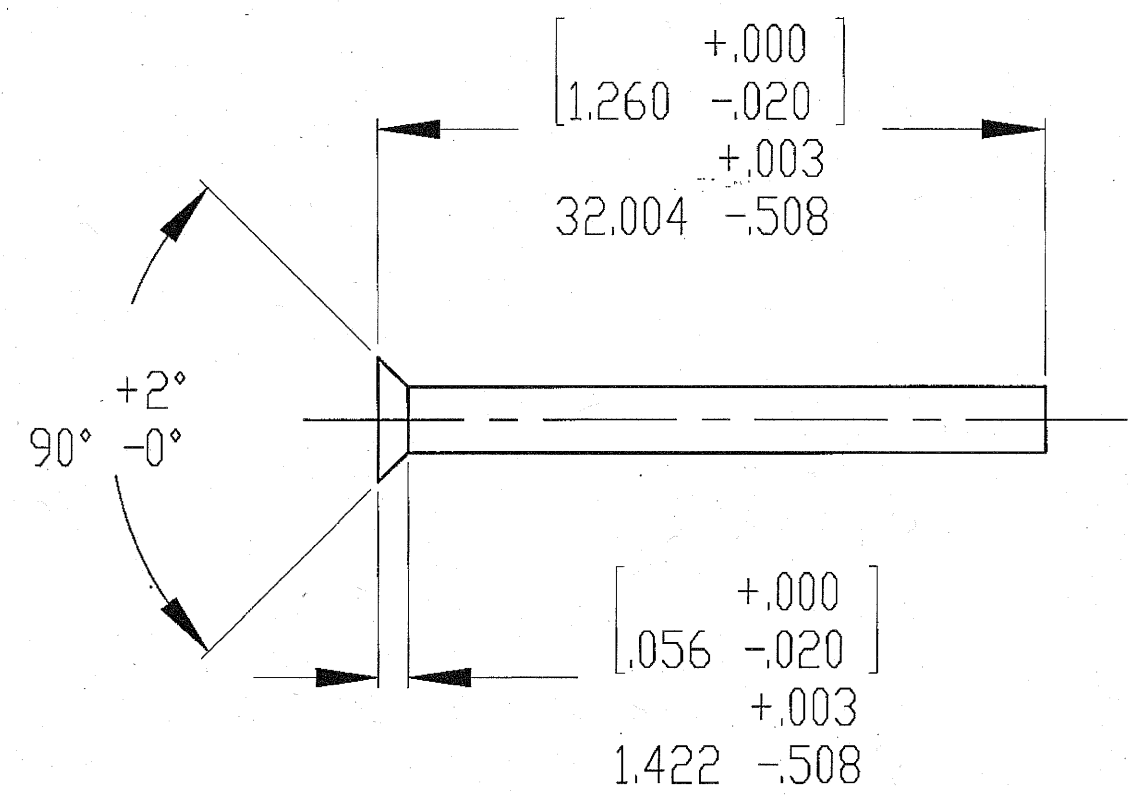

UN CONTROLLED COPY  
 CERTIFIED CORRECT COPY OF APPROVED  
 DRAWINGS AT THIS DATE 29.09.2021  
 DESIGN & DRAWING OFFICE,  
 ORDNANCE FACTORY, TIRUCHIRAPPALI -520 016.

Provisionally Approved  
 2-4 AUG 2021  
 for Encl (API)

NOTES:

- BREAK EDGES 0.076 + 0.305 UNLESS OTHERWISE SPECIFIED.
- ASME Y14.5M-1994 APPLIES.

PROPRIETARY AND CONFIDENTIAL  
 THE INFORMATION CONTAINED IN THIS DRAWING IS THE SOLE PROPERTY OF OHIO ORDNANCE WORKS, INC. ANY REPRODUCTION IN PART OR AS A WHOLE WITHOUT THE WRITTEN PERMISSION OF OHIO ORDNANCE WORKS, INC. IS PROHIBITED.

UNLESS OTHERWISE SPECIFIED		NAME	DATE	OHIO ORDNANCE WORKS, INC.	
DIMENSIONS ARE IN MM/[INCHES]		DRAWN	HERSH	02/12/08	RIVET, TOPCOVER BRACKET, 00W50BMG
ALL THREAD DIM. ARE IN INCHES		CHECKED			
TOLERANCES:		ENG APPR.			
FRACTIONAL ±0.015		MFG APPR.			
ANGULAR: MACH ±0.5° BEND		Q.A.			SIZE
TWO PLACE DECIMAL ±0.25		COMMENTS:			A
THREE PLACE DECIMAL ±0.076					5152980
INTERPRET GEOMETRIC TOLERANCING PER:					REV
MATERIAL					A
AISI 1018					
FINISH					SCALE: 2:1
DO NOT SCALE DRAWING					WEIGHT:
					SHEET 1 OF 1