

DRG. NO.: M-10857B

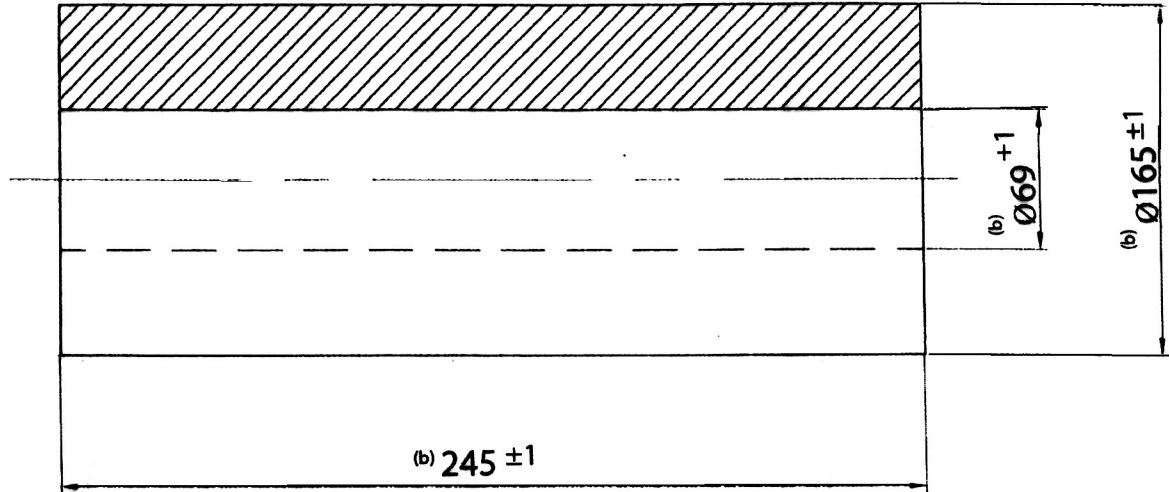



NOTE:
U.S.T TO BE CARRIED OUT ON MACHINED TUBE AFTER HEAT TREATMENT.

MATERIAL SPECIFICATION: REFER DOCUMENT ID : 301171080

ALL DIMENSIONS ARE IN mm.

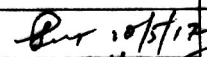
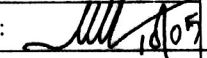
AMENDMENT MADE VIDE MEMO No. 061/DRG/84 M3 DATED : 09.05.2017

	#(b) DIM. 245±1, Ø 69+1, Ø165±1 WERE 250 MIN, Ø62, Ø180 & NOMENCLATURE AMENDED VIDE GUN-B MEMO NO. - GUN-B/AB/25/1718/DRG. Dt.- 07/03/2018 DRG. NO ADVANCED TO 'B'	SCHEDULE NO.	COMPT. :	ST. DRG. NO. :
		SCALE: NTS	PROJECTION THIRD ANGLE	84 MM RL MK-III VENTURI
09/03/18 23/18 D.A.NO.		DRAWN BY: M. Paul	SINGLE PIECE PYT FORGING BLANK FOR VENTURI FOR 84 mm RL MK-III	
		TRACED BY:		
11/17 D.A.NO.	AMENDMENT IN ALL DIMENSIONS AND DOCUMENT No.	CHECKED BY: 	DRG. NO.: M-10857B	
		APPROVED BY: 		
DT. & SG.	DESCRIPTION	CONCURRED BY: JWM/GUN-B	M/C:	NO. OF SHEET: 1
AMENDMENTS	DATE: 10 May 17	SIGR.: 	G & S FY. COSSIPORE	SHEET NO.: 1

A.De

ALL DIMNS. ARE IN mm.
UNTOL DIMNS. ARE AS PER IS:2102.

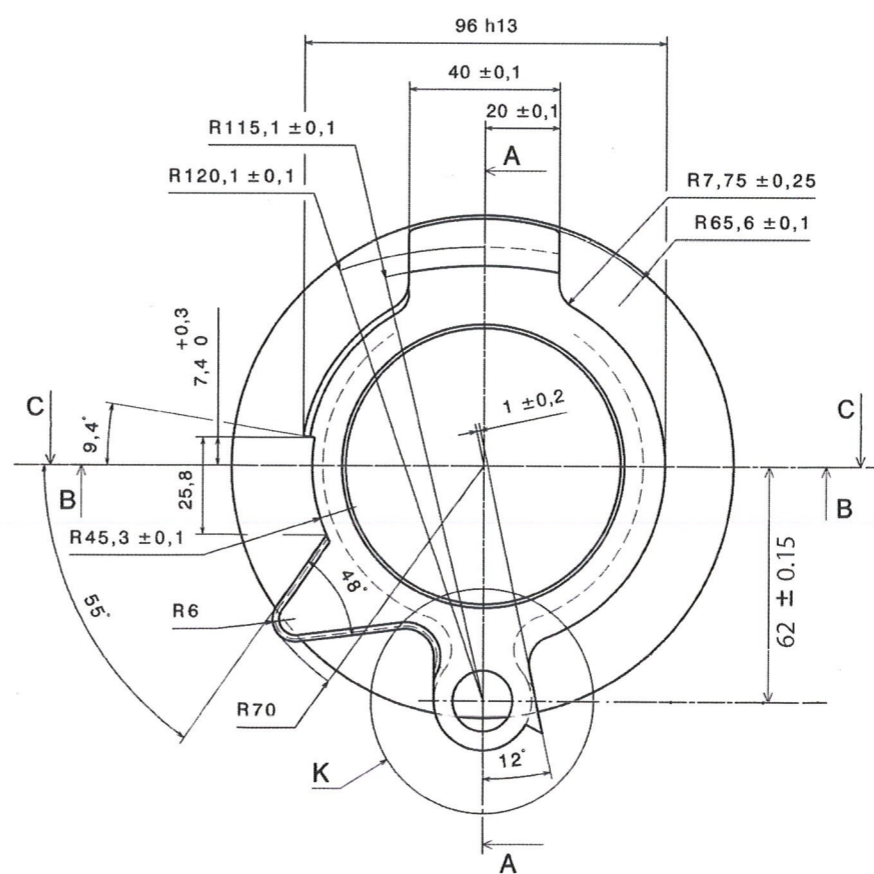
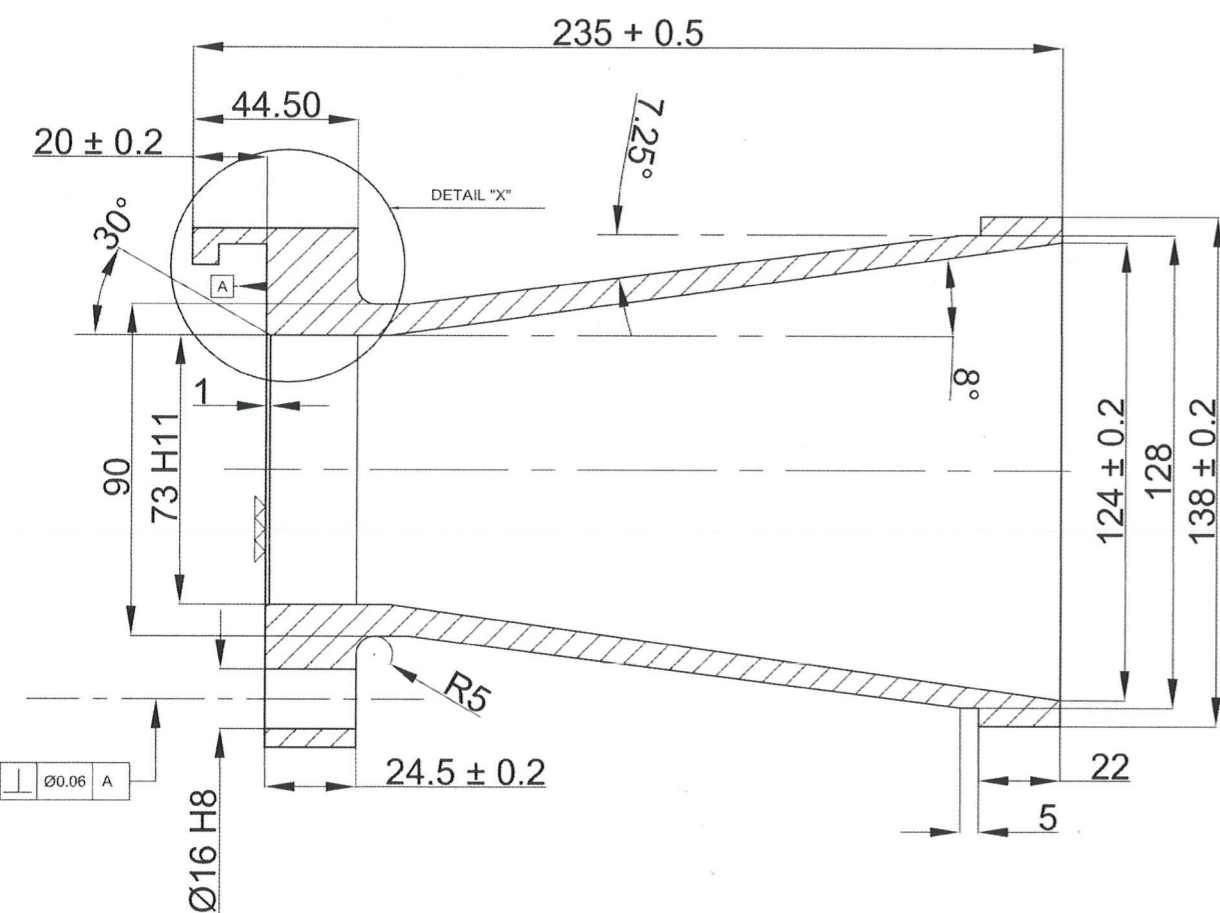
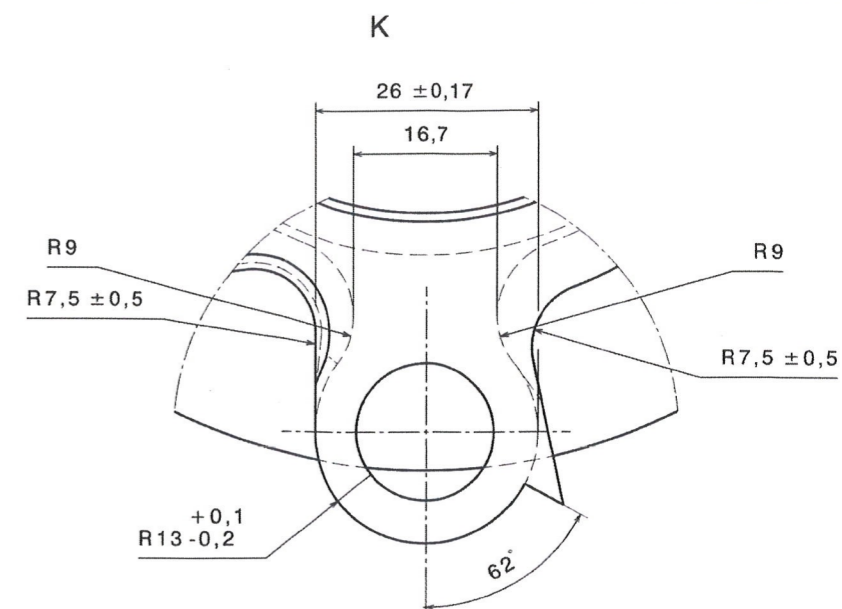
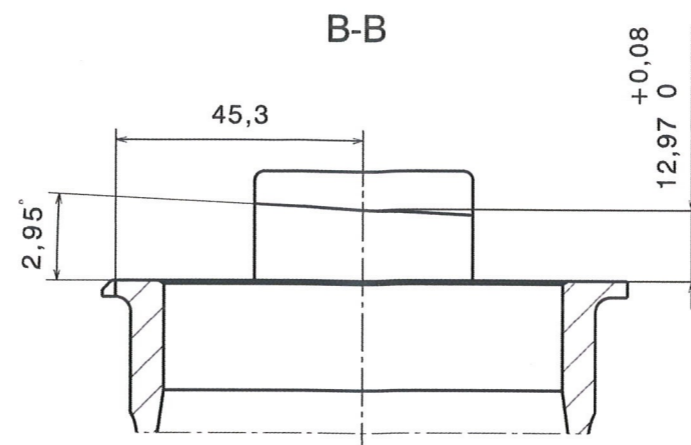
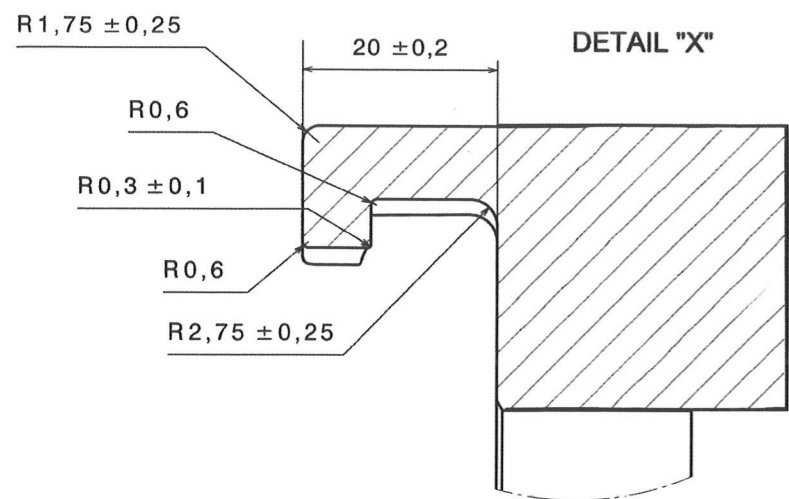

A - A

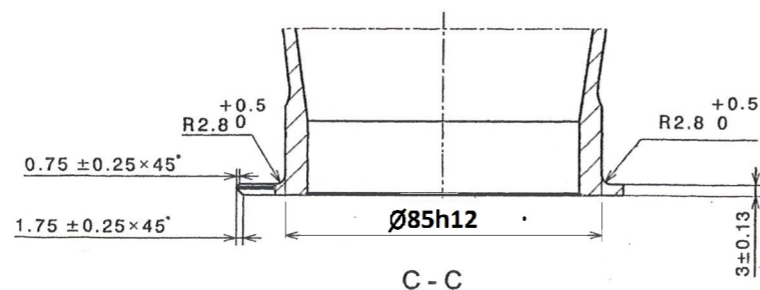

Material According to
Specification: 301171080

ITEM NO.	NO. OFF	MATERIAL	DESCRIPTION
LIST OF PARTS			

COMPONENT		STORE DRG. NO
VENTURI		84 MM RL MK- III
SEMI FINISHED VENTURI		
DRG NO:- M-11593		
DT. & SG.	DESCRIPTION	NO. OF SHTS:
AMENDMENTS	DATE: 08/06/23 SIGN: [Signature]	SHT. NO:

SCHEDULE NO.:		COMPONENT	STORE DRG. NO
SCALE:	PROJECTION:	VENTURI	84 MM RL MK- III
	THIRD ANGLE	SEMI FINISHED VENTURI	
DRAWN BY: SUBHASH		DRG NO:- M-11593	
CHECKED BY:		DT. & SG.	DESCRIPTION
APPROVED BY: [Signature]		AMENDMENTS	DATE: 08/06/23 SIGN: [Signature]
CONCURRED BY: JWM/GUN-E		NO. OF SHTS:	
		SHT. NO:	