



DIMENSIONS ARE IN mm.

UNTOLERATED DIMNS. AS PER IS : 2102 (MED)

SHARP CORNERS SHOULD BE BLUNT TO R 0.5

PROTECTIVE FINISH : PHOSPATED TO SPECIFICATION. JSS : 0465-01-1988

CLASS-I (ACCELERATED) OIL FINISH.

DRG. FOR GUIDANCE ONLY.  
FIRM MAY STUDY THE SAMPLE  
AVAILABLE AT OFT BEFORE  
QUOTE.

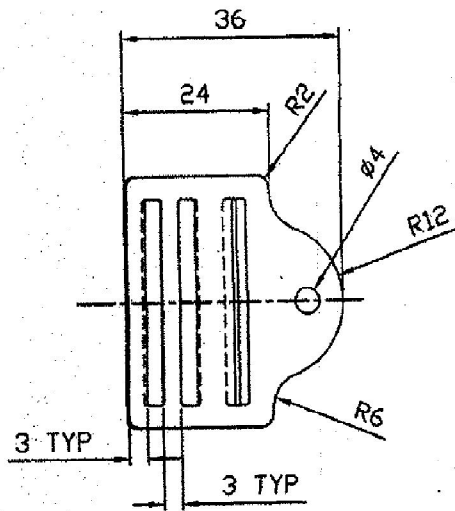

VERIFIED CORRECT COPY  
OF APPROVED DRAWINGS  
AT THIS DATE 6.9.18

Design & Drawing Office  
Ordnance Factory  
Tiruchirappalli-16

UNCONTROLLED COPY

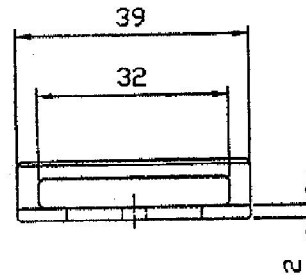
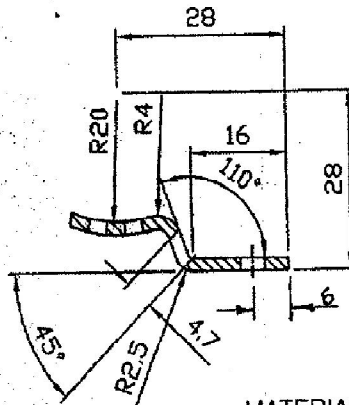

MATERIAL:- IS:7226 C40 (OR) C55.  
HARDNESS:- 250 - 300 H.V.

2/10

DGM  
NODAL OFFICER  
(TAR)

PART NO.	DESCRIPTIONS	NO OFF	MATERIAL	TREATMENT	REMARKS
	SIGNATURE & DATE.	SUB: ADJUSTABLE LINK			SCALE NTS
	TRACED	FOR: SLING ASSY			STORE DRG.NO.
	DRAWN <i>SK</i>	OF: TRICHY ASSAULT RIFLE			---
	CHECKED	DES.REF.NO.			OPERATION NO.
	HOS/D&DO <i>R</i>	DRG. No.: TAR-RB-K-9007			
	OFFICER/PRDN.	ORDNANCE FACTORY TIRUCHIRAPPALLI-16.			SHEETS: 10
OFFICER/D&DO	APPROVED ON.				SHEET No.: 2

AMENDMENTS SIG. & DATE



DIMENSIONS ARE IN mm.

UNTOLERATED DIMNS. AS PER IS : 2102 (MED)

SHARP CORNERS SHOULD BE BLUNT TO R 0.5

DRG. FOR GUIDANCE ONLY.  
FIRM MAY STUDY THE SAMPLE  
AVAILABLE AT OFT BEFORE  
QUOTE.

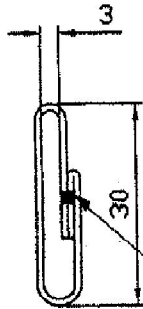
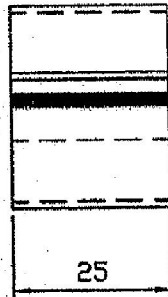

3 NOS PER SLING.

STITCHING

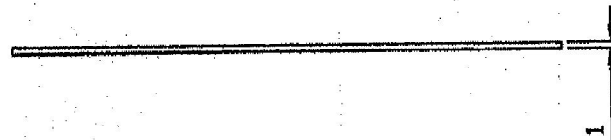
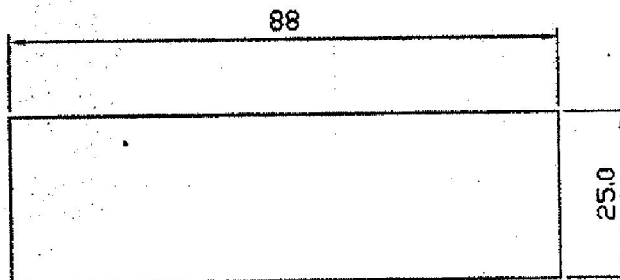

VERIFIED CORRECT COPY  
OF APPROVED DRAWINGS  
AT THIS DATE. 6.11.18

Design & Drawing Office  
Ordnance Factory,  
Tiruchirappalli 620014

UN CONTROLLED COPY

MATERIAL:- POLYESTER (OR) NYLON (OR) COTTON  
TYPE:- ELASTIC FABRIC BAND (WEBBING)

4/10

DGM  
NODAL OFFICER  
(TAR)

PART NO.	DESCRIPTIONS	NO OFF	MATERIAL	TREATMENT	REMARKS
⊕	SIGNATURE & DATE.		SUB: ELASTIC BAND		SCALE
TRACED			FOR: SLING ASSY		NTS
DRAWN	<i>SK</i>		OF : TRICHY ASSAULT RIFLE		STORE DRG.NO.
CHECKED			DES. REF. NO.		---
HOS/D&DO	<i>SK</i>		DRG. No.: TAR-RB-K- 9007		OPERATION NO.
OFFICER/ PRODN.			ORDNANCE FACTORY		SHEETS: 10
OFFICER/ D&DO	<i>SK</i>		TIRUCHIRAPPALLI-16.		SHEET No.: 4
AMENDMENTS	SIG. & DATE	APPROVED ON.	FT		



DIMENSIONS ARE IN mm.  
UNTOLERATED DIMNS. AS PER IS : 2102 (MED)  
SHARP CORNERS SHOULD BE BLUNT TO R 0.5

PROTECTIVE FINISH : PHOSPATED TO SPECIFICATION. JSS : 0465-01-1988  
CLASS-I (ACCELERATED) OIL FINISH.

DRG. FOR GUIDANCE ONLY.  
 FIRM MAY STUDY THE SAMPLE  
 AVAILABLE AT OFT BEFORE  
 QUOTE.

CERTIFIED CORRECT COPY  
 OF APPROVED DRAWING  
 AT THIS DATE *6/18*

Design & Drawing Office  
 Ordnance Factory,  
 Tiruchirappalli

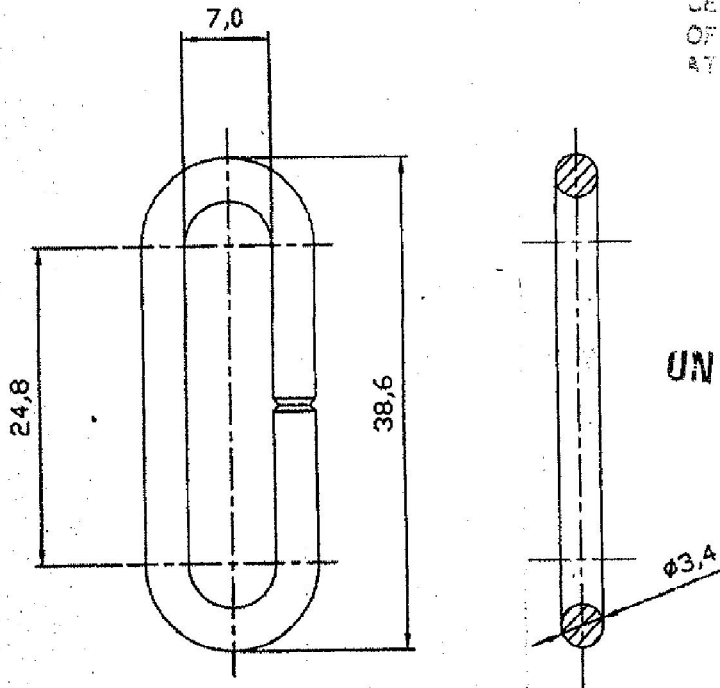

UN CONTROLLED COPY

MATL:-

STEEL TO BS:970: Pt.1: 1983. GRADE 080 M40.

6/10

DGM  
 NODAL OFFICER  
 (TAR)

PART NO.	DESCRIPTIONS	NO OFF	MATERIAL	TREATMENT	REMARKS
⊕	SIGNATURE & DATE.				SCALE NTS
	TRACED				STORE DRG.NO.
	DRAWN <i>[Signature]</i>				---
	CHECKED				OPERATION NO.
	HOS/D&DO <i>[Signature]</i>				---
	OFFICER/ PRODN.				SHEETS: 10
	OFFICER/ D&DO <i>[Signature]</i>				SHEET No.: 6
AMENDMENTS	SIG. & DATE	APPROVED ON.	ORDNANCE FACTORY TIRUCHIRAPPALLI-16.		

SUB: LINK  
 FOR: SLING ASSY  
 OF : TRICHY ASSAULT RIFLE

DES. REF. NO.  
 DRG. No.: TAR-RB-K-9007



ORDNANCE FACTORY  
 TIRUCHIRAPPALLI-16.

DIMENSIONS ARE IN mm.  
 UNTOLERATED DIMNS. AS PER IS : 2102 (MED)  
 SHARP CORNERS SHOULD BE BLUNT TO R 0.5

PROTECTIVE FINISH : PHOSPATED TO SPECIFICATION. JSS : 0465-01-1988  
 CLASS-II (ACCELERATED) OIL FINISH.

CERTIFIED CORRECT COPY  
 OF APPROVED DRAWINGS  
 AT THE DATE 6.9.18

DRG. FOR GUIDANCE ONLY.  
 FIRM MAY STUDY THE SAMPLE  
 AVAILABLE AT OFT BEFORE  
 QUOTE.

Design & Drawing Officer

IN CONTROL COPY

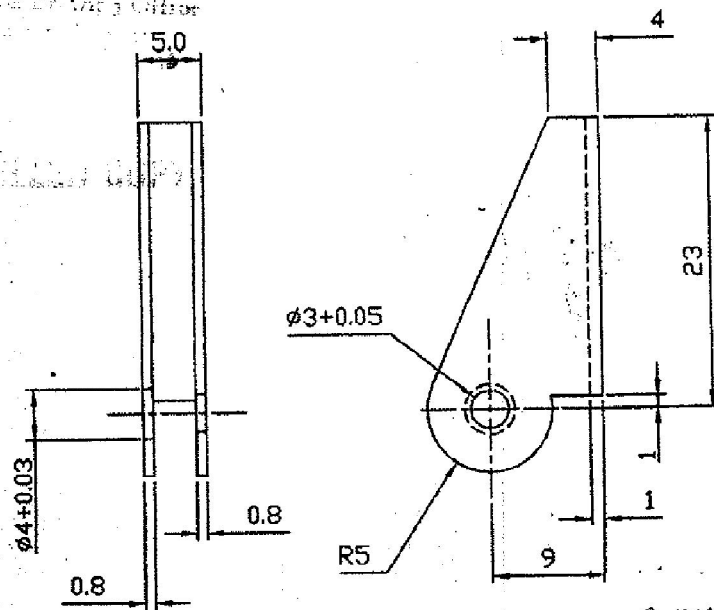

2 NOS. PER SLING.

MATL:- IS: 7226 C40 (OR) C55.  
 ALT. MATL:- BS 1449: Pt.1: 1983, Grade. CS-40.  
 HARDNESS:- 250 - 325 H.V.

7/10

DGM  
 NODAL OFFICER  
 (TAR)

PART NO.	DESCRIPTIONS	NO OFF.	MATERIAL	TREATMENT	REMARKS
	SIGNATURE & DATE.	SUB: LOCK, HOOK FOR: SLING ASSY OF : TRICHY ASSAULT RIFLE			SCALE NTS
	TRACED				STORE DRG.NO. ---
	DRAWN	DES.REF.NO.			OPERATION NO. ---
	CHECKED	DRG. No.: TAR-RB-K- 9007			SHEETS: 10
	HOS/D&DO	ORDNANCE FACTORY TIRUCHIRAPPALLI-16.			SHEET No.: 7
	OFFICER/PRODN.				
	OFFICER/D&DO				
AMENDMENTS	SIG. & DATE	APPROVED ON.			



DIMENSIONS ARE IN mm.  
 UNTOLERATED DIMNS. AS PER IS : 2102 (MED)  
 SHARP CORNERS SHOULD BE BLUNT TO R 0.5

PROTECTIVE FINISH : PHOSPATED TO SPECIFICATION. JSS : 0465-01-1988  
 CLASS-II (ACCELERATED) OIL FINISH.

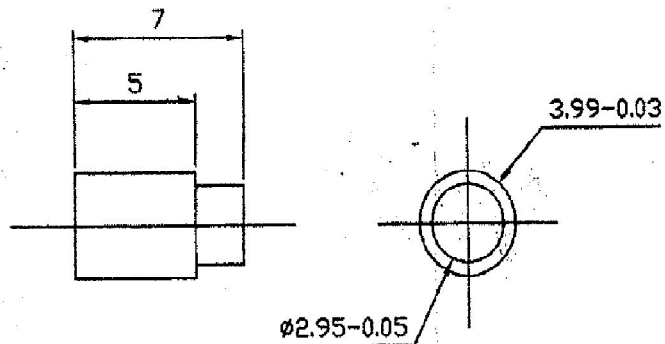

CERTIFIED CORRECT COPY  
 OF APPROVED DRAWINGS  
 AT THIS DATE ... 6.4.18 ...

Design & Drawing Office  
 Ordnance Factory

2 NOS. PER SLING.



UN CONTROLLED COPY

MATL:-

STEEL TO BS:970: Pt.1: 1983. GRADE 080 M40

8/10

DGM  
 NODAL OFFICER  
 (TAR)

PART NO.	DESCRIPTIONS	NO OFF	MATERIAL	TREATMENT	REMARKS
 TRACED DRAWN CHECKED HOS/D&DO OFFICER/ PRODN. OFFICER/ D&DO	SIGNATURE & DATE.	SUB: PIN, AXIS LOCK HOOK			SCALE NTS
		FOR: SLING ASSY			STORE DRG.NO.
		OF : TRICHY ASSAULT RIFLE			---
		DES.REF.NO.			OPERATION NO.
		DRG. No.: TAR-RB-K- 9007			---
AMENDMENTS	SIG. & DATE	APPROVED ON.	 ORDNANCE FACTORY TIRUCHIRAPPALLI-16.		SHEETS: 19 SHEET No.: 8



OF APPROVED THE WORK  
AT THIS DATE 16/10/07

Division of Forensic Chemistry  
Criminal Investigation  
Forensic Chemistry Laboratory

16/10/07



1

2

3



4

5

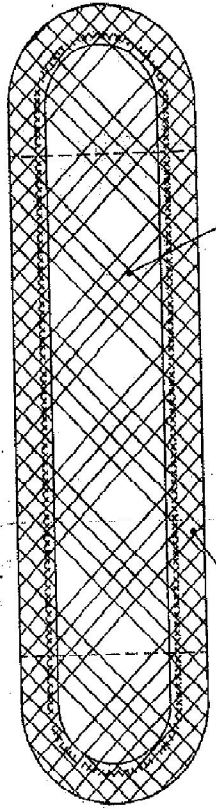

3

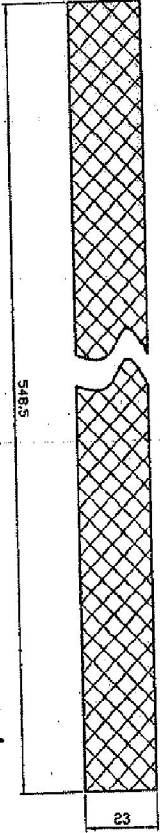

5

54.85

2



4

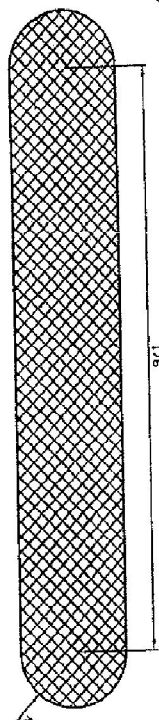

176

9/10

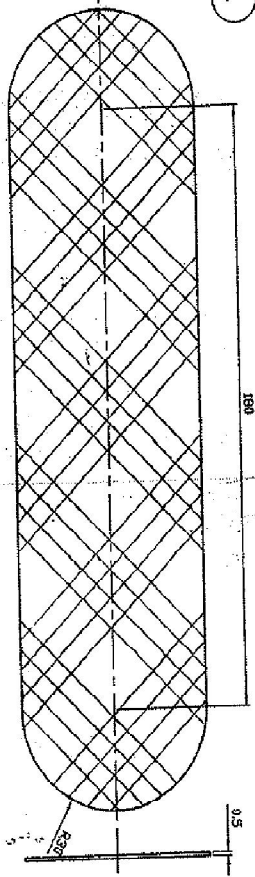

1

180

9.5

DRG. FOR GUIDANCE ONLY.  
FIRM MAY STUDY THE SAMPLE  
AVAILABLE AT OFT BEFORE  
QUOTE.

DDM  
MODAL OFFICER  
(IPR)

APPROVED DATE APPROVED BY

SC. DATE APPROVED BY

APPROVED BY DATE APPROVED BY

APPROVED BY DATE APPROVED BY

APPROVED BY DATE APPROVED BY

APPROVED BY DATE APPROVED BY

APPROVED BY DATE APPROVED BY

APPROVED BY DATE APPROVED BY

APPROVED BY DATE APPROVED BY

APPROVED BY DATE APPROVED BY

APPROVED BY DATE APPROVED BY

APPROVED BY DATE APPROVED BY

NO.	DESCRIPTION	QTY	MATERIAL	TREATMENT	REMARKS
5	OUTER CLOTH	1	AS ABOVE		
4	INNER CLOTH	1	AS ABOVE		
3	NYLON RIB	1	AS ABOVE		
2	SPONGE	1	AS ABOVE		
1	COTTON CLOTH	2	AS ABOVE		

SUB: SHOULDER GRIP  
FOR SLING ASSY  
OF TRICHY ASSAULT RIFLE  
DRG. NO. TAR-RB-K-3007  
ORDNANCE FACTORY  
TIRUCHIRAPPALLI-16  
OPERATION NO.  
SHEET NO. 10

DIMENSIONS ARE IN mm.  
UNTOLERATED DIMNS. AS PER IS : 2102 (MED)  
SHARP CORNERS SHOULD BE BLUNT TO R 0.5

PROTECTIVE FINISH : PHOSPATED TO SPECIFICATION. JSS : 0465-01-1988  
CLASS-I (ACCELERATED) OIL FINISH.

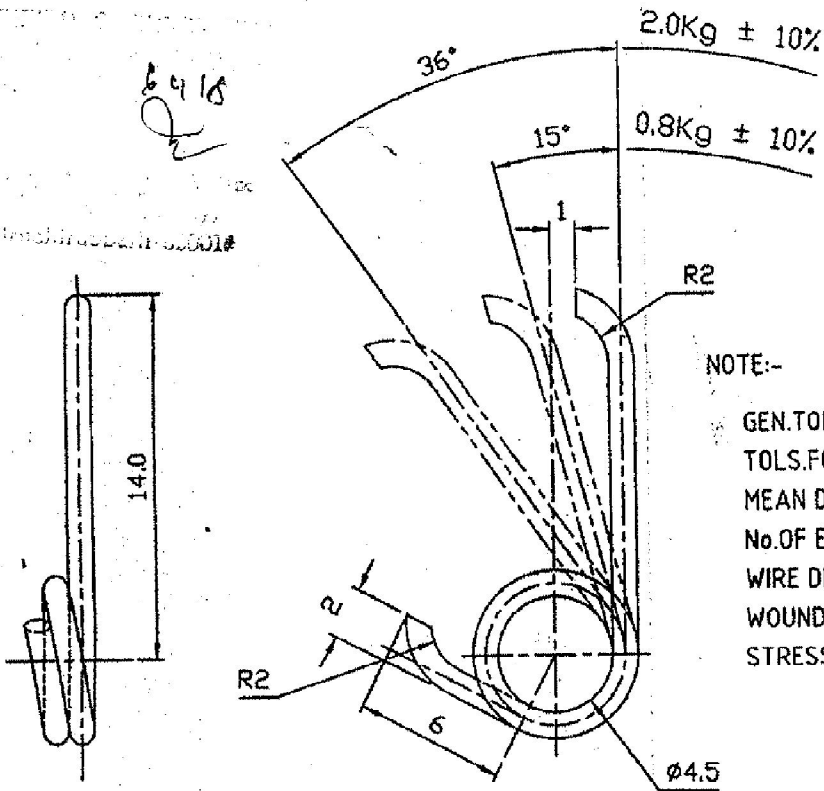

NOTE:-

GEN.TOL ±0.2  
TOLS.FOR ANGLES ± 30'  
MEAN DIA. -----5.5  
No.OF EFFECTIVE COILS-----1  
WIRE DIA. -----1.0  
WOUND. -----RH.  
STRESS RELIEVED.

2 NOS. PER SLING.

MATERIAL:- IS:4454: Pt.1 2001 GRADE DH

10/10

DGM  
NODAL OFFICER  
(TAR)

PART NO.	DESCRIPTIONS	NO OFF.	MATERIAL	TREATMENT	REMARKS
	SIGNATURE & DATE.				SCALE NTS
	TRACED				STORE DRG.NO.
	DRAWN				---
	CHECKED				OPERATION NO.
	HOS/D&DO				---
	OFFICER/PRODN.				SHEETS: 10
	OFFICER/D&DO				SHEET No.: 10
AMENDMENTS	SIG. & DATE	APPROVED ON.	ORDNANCE FACTORY TIRUCHIRAPPALLI-16.		

