

NOTES:

1. FINISH $\sqrt{3.2}$ EXCEPT AS NOTED.
2. BREAK EDGES 0.076 ± 0.304 UNLESS OTHERWISE SPECIFIED.
3. MATERIAL: STEEL, ASTM A331 OR A322; 4340, 4140, 6150.
4. ASTM Y14.5M-1994 APPLIES.
5. HEAT TREATMENT:
 - A. AUSTENITIZE, QUENCH AND DOUBLE TEMPER (2 HOURS + 1 HOUR) PER AMS 2759. MINIMUM TEMPERING TEMPERATURE 204°C . TO HRC 52-58.
 - B. LOCALLY INDUCTION TEMPER 4.82 RADIUS ZONE TO HRC 32 MINIMUM (TO PRODUCE A MACHINABLE CONDITION). DUE TO THE NATURE OF THE INDUCTION HEATING PROCESS, TEMPERED ZONE RADIUS IS APPROXIMATE MAXIMUM.

UN CONTROLLED COPY
 CERTIFIED CORRECT COPY OF APPROVED
 DRAWINGS AT THIS DATE. 23 Aug 2021
 DESIGN & DRAWING OFFICE,
 ORDNANCE FACTORY, TIRUCHIRAPPALI -620 016.

24 AUG 2021
 for Crude (API)

REVISIONS				
ZONE	REV.	DESCRIPTION	DATE	APPROVED
	A	CREATE DRAWING	4/9/2009	J. HERSHBERGER
C-2	B	ADDED GRAIN DIRECTION CALLOUT	6/1/2009	J. HERSHBERGER
C		ADDED SHEETS 2 AND 3 (COMPARATOR CHARTS)	7/8/2009	J. HERSHBERGER
B-5/E-4	D	REMOVED 'MAX' CALLOUT FROM BOTH 5" AND .060 DIMENSIONS; CHANGED .060 TO .05	8/10/2012	J. HERSHBERGER
B-4	E	ADDED R010 ± 0.05 TO TWO EDGES IN DETAIL B	12/11/2019	T. HARDMAN

M-3002

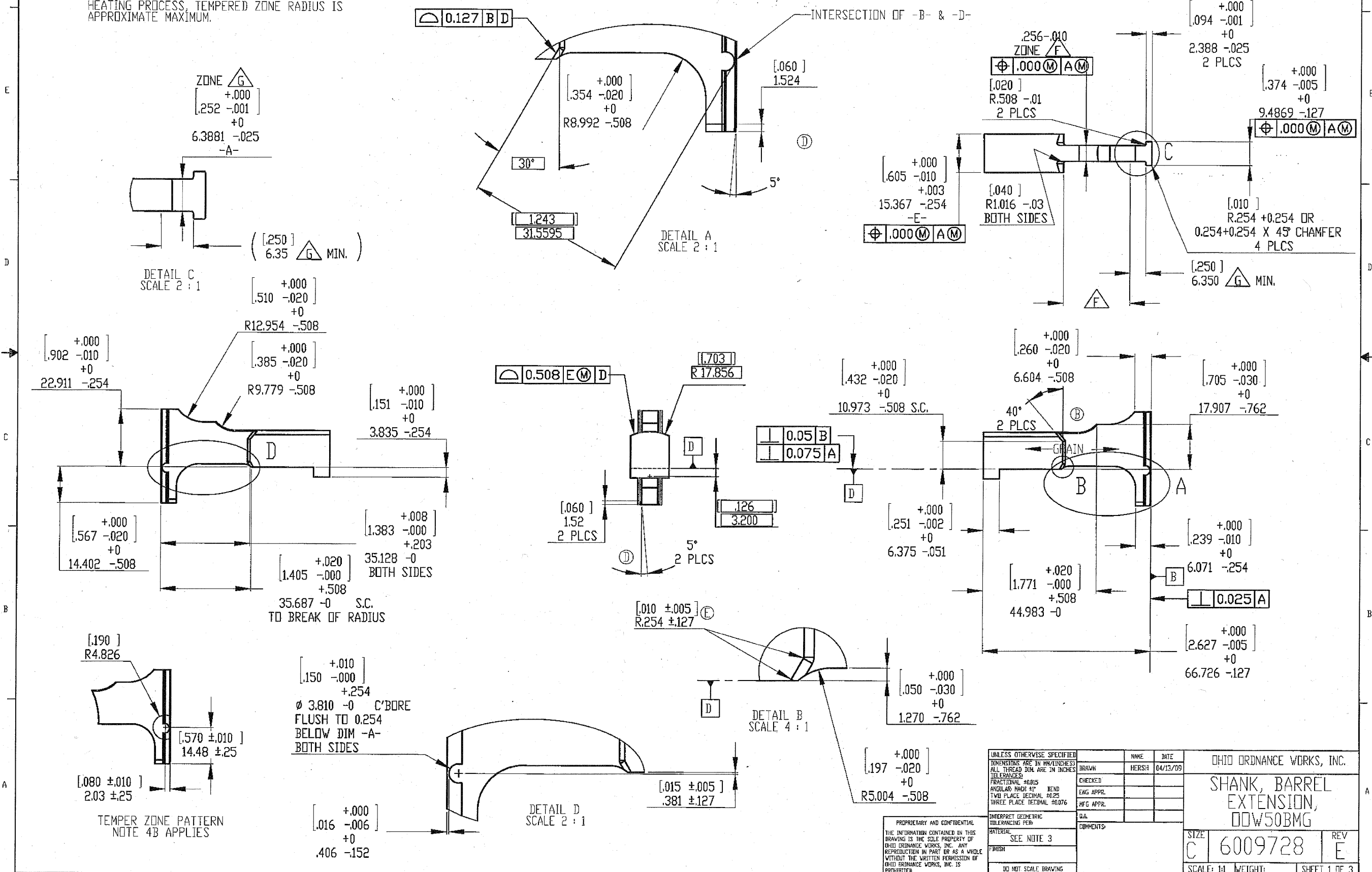

UNLESS OTHERWISE SPECIFIED		NAME	DATE	OHIO ORDNANCE WORKS, INC.
DIMENSIONS ARE IN MM/INCHES ALL THREAD DIM. ARE IN INCHES		BRAWN	HERSH	
TOLERANCES:		CHECKED		SHANK, BARREL EXTENSION, DDW50BMG
FRACTIONAL .005		ENG APPR.		
ANGULAR: MAXI 45° BEND TWO PLACE DECIMAL .025 THREE PLACE DECIMAL .0076		HFG APPR.		
MATERIAL		D.A.		SIZE C 6009728
SEE NOTE 3		COMMENTS:		
FINISH				REV E
DO NOT SCALE DRAWING				SCALE: 1:1 WEIGHT: SHEET 1 OF 3

PROPRIETARY AND CONFIDENTIAL
 THE INFORMATION CONTAINED IN THIS
 DRAWING IS THE SOLE PROPERTY OF
 OHIO ORDNANCE WORKS, INC. ANY
 REPRODUCTION IN PART OR AS A WHOLE
 WITHOUT THE WRITTEN PERMISSION OF
 OHIO ORDNANCE WORKS, INC. IS
 PROHIBITED.

M-3002

[.0025]
.0635

[.0025]
.0635

1.2425
31.5595

[1.250]
31.750
SHIFT LINE
FROM -B-

UN CONTROLLED COPY
CERTIFIED CORRECT COPY OF APPROVED
DRAWINGS AT THIS DATE 29-09-2021
DESIGN & DRAWING OFFICE,
ORDNANCE FACTORY, TIRUCHIRAPPALI-620 016.

अप्रमाणित रूप से प्रमाणित
Provisionally Approved
24 AUG 2021
रिजिस्टर्ड
हस्ताक्षर/Sig
For Control (AP)

PROPRIETARY AND CONFIDENTIAL
THE INFORMATION CONTAINED IN THIS
DRAWING IS THE SOLE PROPERTY OF
DHIO ORDNANCE WORKS, INC. ANY
REPRODUCTION IN PART OR AS A WHOLE
WITHOUT THE WRITTEN PERMISSION OF
DHIO ORDNANCE WORKS, INC. IS
PROHIBITED.

UNLESS OTHERWISE SPECIFIED	
DIMENSIONS ARE IN MM/[INCHES]	
ALL THREAD DIM. ARE IN INCHES	
TOLERANCES:	
FRACTIONAL	
ANGULAR: MACH ± BEND	
TWO PLACE DECIMAL ±	
THREE PLACE DECIMAL ±	
INTERPRET GEOMETRIC TOLERANCING PER:	
MATERIAL	SEE NOTE 13
FINISH	
DO NOT SCALE DRAWING	

	NAME	DATE
DRAWN	HERSH	04/13/09
CHECKED		
ENG APPR.		
MFG APPR.		
Q.A.		
COMMENTS:		

DHIO ORDNANCE WORKS, INC.		
COMPARATOR CHART		
FOR	0.127	B D
ZONE E-6; SHT 1		
SIZE	6009728	REV
A		E
SCALE: 10:1	WEIGHT:	SHEET 2 OF 3

M. 3002

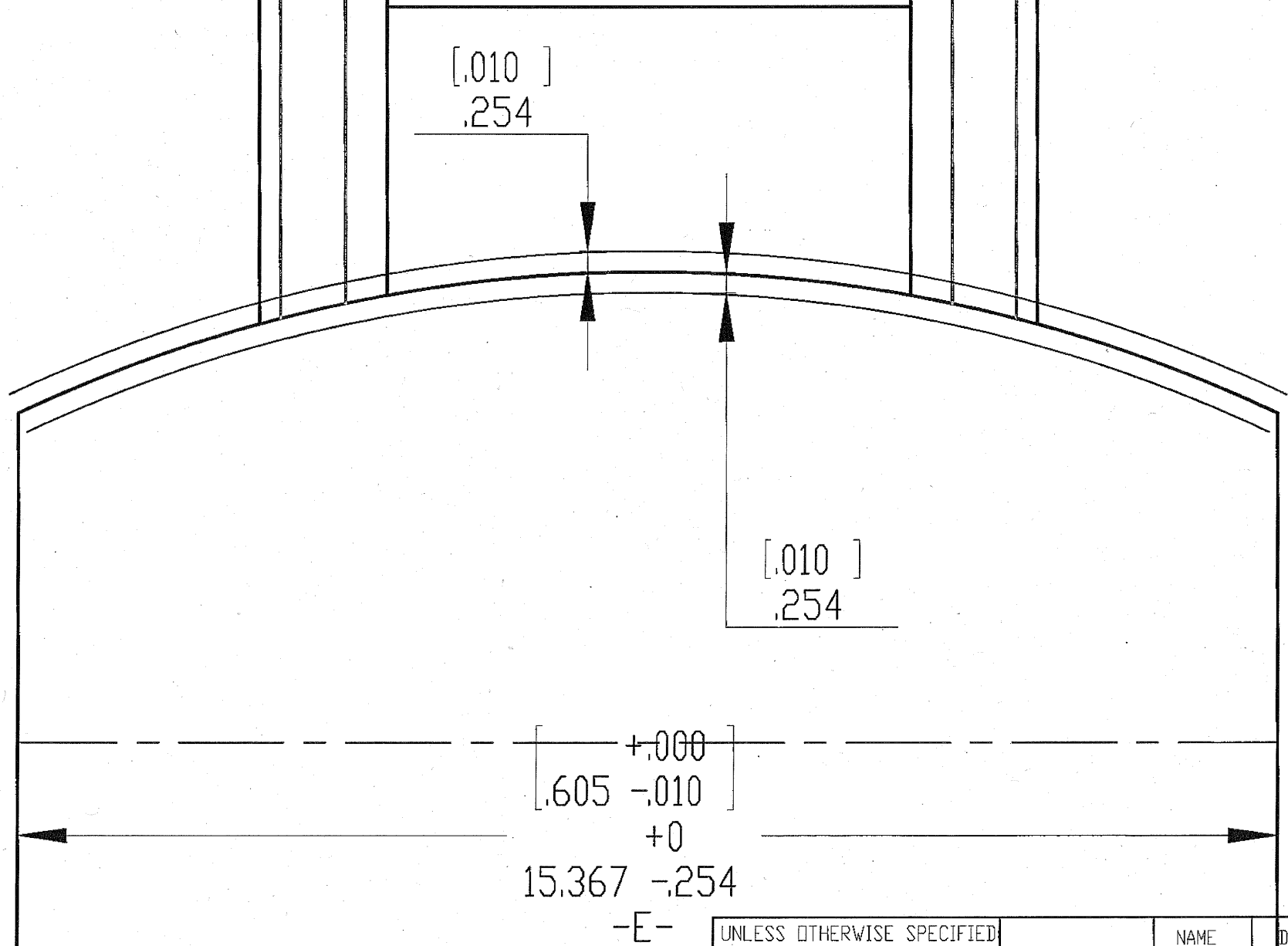

[.350]
8.890
SHIFT LINE
FROM -D-

UN CONTROLLED COPY
CERTIFIED CORRECT COPY OF APPROVED
DRAWINGS AT THIS DATE. 29.09.2021
DESIGN & DRAWING OFFICE, *[Signature]*
ORDNANCE FACTORY, TIRUCHIRAPPALI - 620 016.

अनुमोदित का ही प्रमाणित
Provisionally Approved
24 AUG 2021 *[Signature]*
रिजिस्टर/Reg
for Code (API)

PROPRIETARY AND CONFIDENTIAL
THE INFORMATION CONTAINED IN THIS
DRAWING IS THE SOLE PROPERTY OF
DHIO ORDNANCE WORKS, INC. ANY
REPRODUCTION IN PART OR AS A WHOLE
WITHOUT THE WRITTEN PERMISSION OF
DHIO ORDNANCE WORKS, INC. IS
PROHIBITED.

UNLESS OTHERWISE SPECIFIED
DIMENSIONS ARE IN MM/[INCHES]
ALL THREAD DIM. ARE IN INCHES
TOLERANCES:
FRACTIONAL
ANGULAR: MACH ± BEND
TWO PLACE DECIMAL ±
THREE PLACE DECIMAL ±
INTERPRET GEOMETRIC
TOLERANCING PER:
MATERIAL SEE NOTE 3
FINISH
DO NOT SCALE DRAWING

	NAME	DATE
DRAWN	HERSH	04/13/09
CHECKED		
ENG APPR.		
MFG APPR.		
Q.A.		
COMMENTS:		

DHIO ORDNANCE WORKS, INC.		
COMPARATOR CHART FOR $\overline{\cup}$ 0.50 E^{M} D ZONE C-5,6; SHT 1		
SIZE A	6009728	REV E
SCALE: 10:1	WEIGHT:	SHEET 3 OF 3