

USED ON  
765-58-5155 1/1

USED ON  
765-58-50155 1/1

1. Alternate material is casting from steel 300, 350, and 40A GOST 977-75.

2. Unspecified limit deviations of dimensions are as follows:  
for holes - as per Aa,  
shafts - as per Bg and  
others - as per Cmg.

3. Unspecified change radii should be 2 mm.

4. Shrinkage cavities of depth not exceeding 1 mm are allowed on handle surfaces.

5. Coating: Zinc-plated, 9 microns thick, oiled. Coating may be absent in hole I.

6. Other requirements for the quality of casting are as per OST 3-6265-79

167  
58

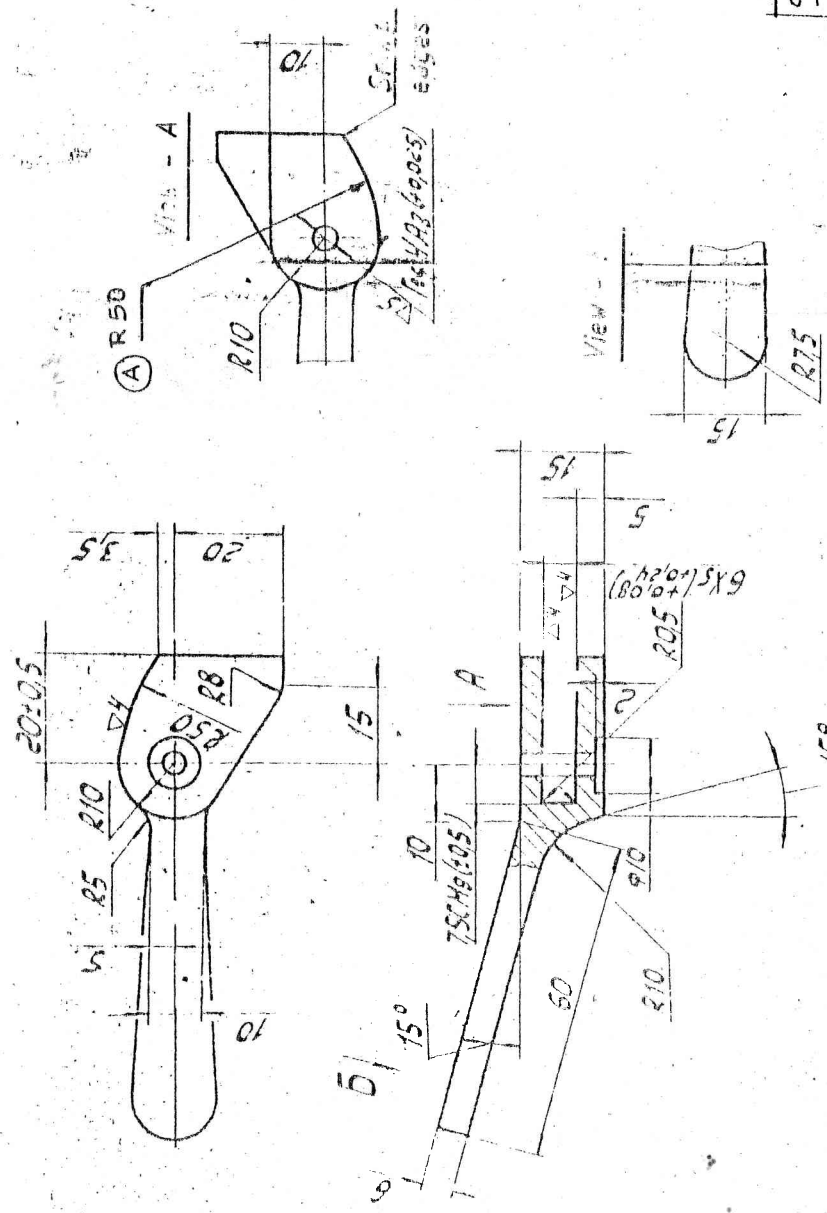

00413 -1CV JAN 94	(B)	D.S. CAT PART NO. "ADDED DESCRIPTION WAS HANDLE."
01201 1CV 05 DEC 90	(A)	R 50 ADDED IN VIEW 'A' (D. 89114)
DC (1) DATE	ISSUE	NATURE OF AMENDMENTS

SKETCH  
⑧ LV2/RV-25 20-1003115  
765-58-74  
LEVER CONTROL SHEET WEIGHT SCALE  
HAND B  
908 1/1  
TOTAL SHEETS

PROVISIONALLY SEALED.

PROVISIONALLY SEALED.

PROPRIETARY  
THE INFORMATION CONTAINED IN THIS DOCUMENT IS PROPRIETARY TO ORDNANCE FACTORY MEDAR (OPRA). ANY USE, REPRODUCING, ASSIGNMENT OR DISCLOSURE IN WHOLE OR IN PART IS SUBJECT TO THE PRIOR WRITTEN CONSENT OF THE GENERAL MANAGER ORDNANCE FACTORY MEDAR.