

**TOP VIEW**

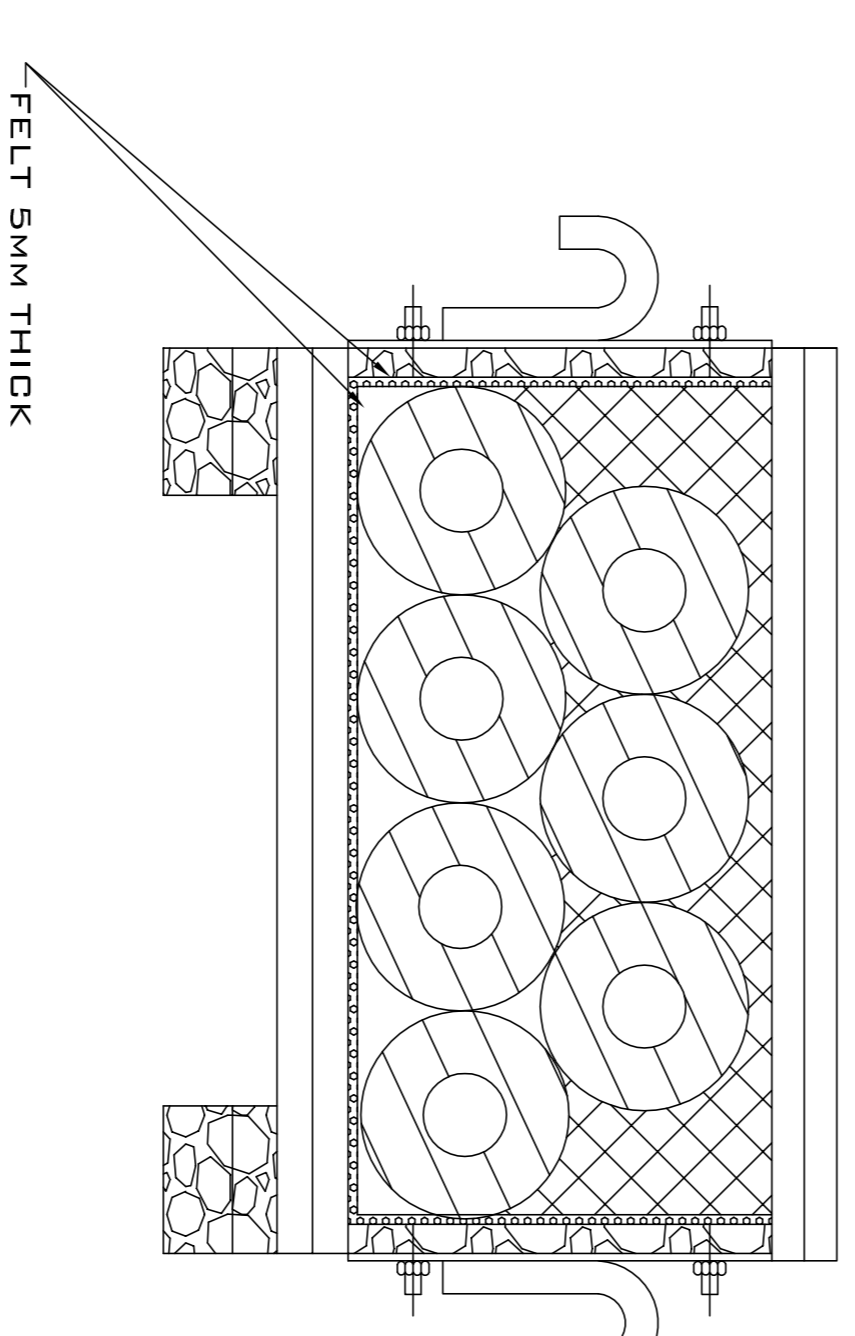
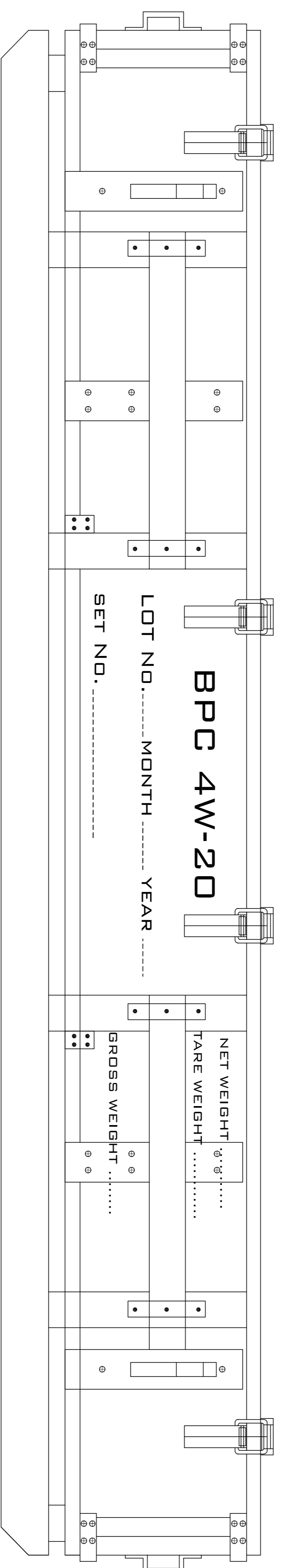

**NOTE:-**  
 THE IN SIDE SPACE OF THE BOX TO BE FILLED WITH  
 PACKING PIECES OR CORRUGATED PAPER TO PREVENT  
 THE RATLING OF GRAIN.

R.No.		DATE		ZONE		BRIF RECORD		AUTHORITY		INITIALS		SCALE :- NTS		TOL		DIMENSIONS ARE IN mm	
11-11-04						APPROVED						DGN		DGN		DGN	
												PASSED		CO/MP		CHD.	
												MATERIAL:-		SINA		FOR PINA	
												MATERIAL SPEC:-		GEN SPEC NA SPEC A31-B		APPROVED	
												PROTECTIVE FINISH:-		STORE SPEC		STORE REF. No.	

**METHOD OF PACKING AND MARKING:-**

**BOX FOR 4 W 20 FILLED**

ASSY DRG. No.

**NAVAL ARMAMENT  
 INSPECTORATE  
 JABALPUR**

DRG.No.  
**NAI(J) 245**  
 SHT 1 OF 2 SHTS  
 (PROVISIONAL)



8

7

6

5

4

3

2

1

SCHEDULE OF COMPONENTS

ITAM NO.	DESCRIPTION	DRAWING NO	NO. OF P.P.	REMARKS
1	LOCKING HOOK	NAI(J) 245/1/1	4	
2	LID BATTEN	NAI(J) 245/1/2	4	

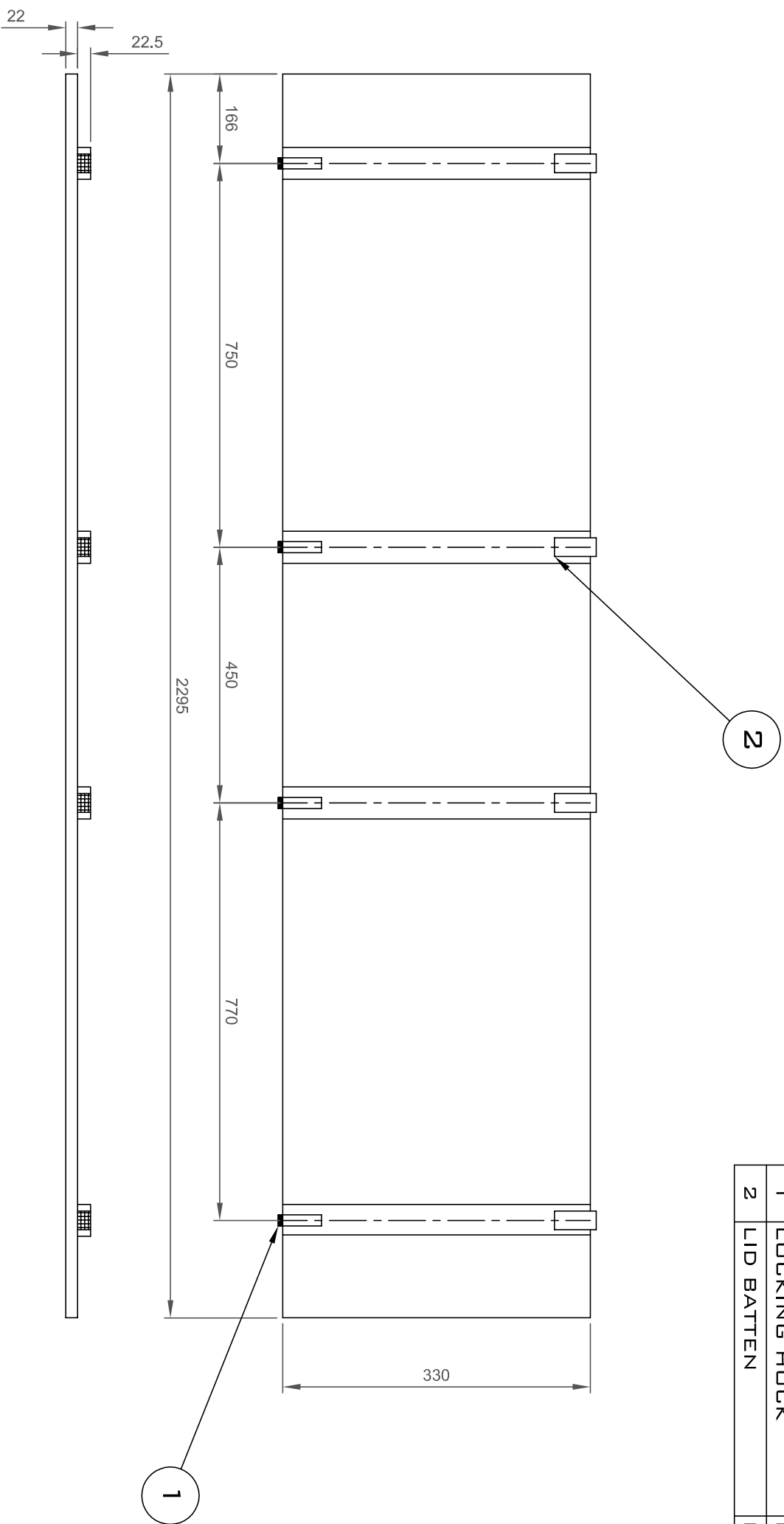

SCALE :- 1:10		TOL		DIMENSIONS ARE IN mm		
DGN	DRN	TCD	COMP	CHD.		
PASSED		SINA		APPROVED		
MATERIAL:- MANGO WOOD		GEN SPEC NA SPEC A31-B		for PINA		
MATERIAL SPEC:- IS - 948		STORE SPEC				
PROTECTIVE FINISH:-		STORE REF. No.				

R.No.	DATE	ZONE	BRIF RECORD	AUTHORITY	INITIALS
	11.11.04		APPROVED		

LID SUB ASSEMBLY

ASSY DRG. No. NAI (J) 245(P)

NAVAL ARMAMENT INSPECTORATE JABALPUR

DRG.No. NAI(J) 245/1 (PROVISIONAL)

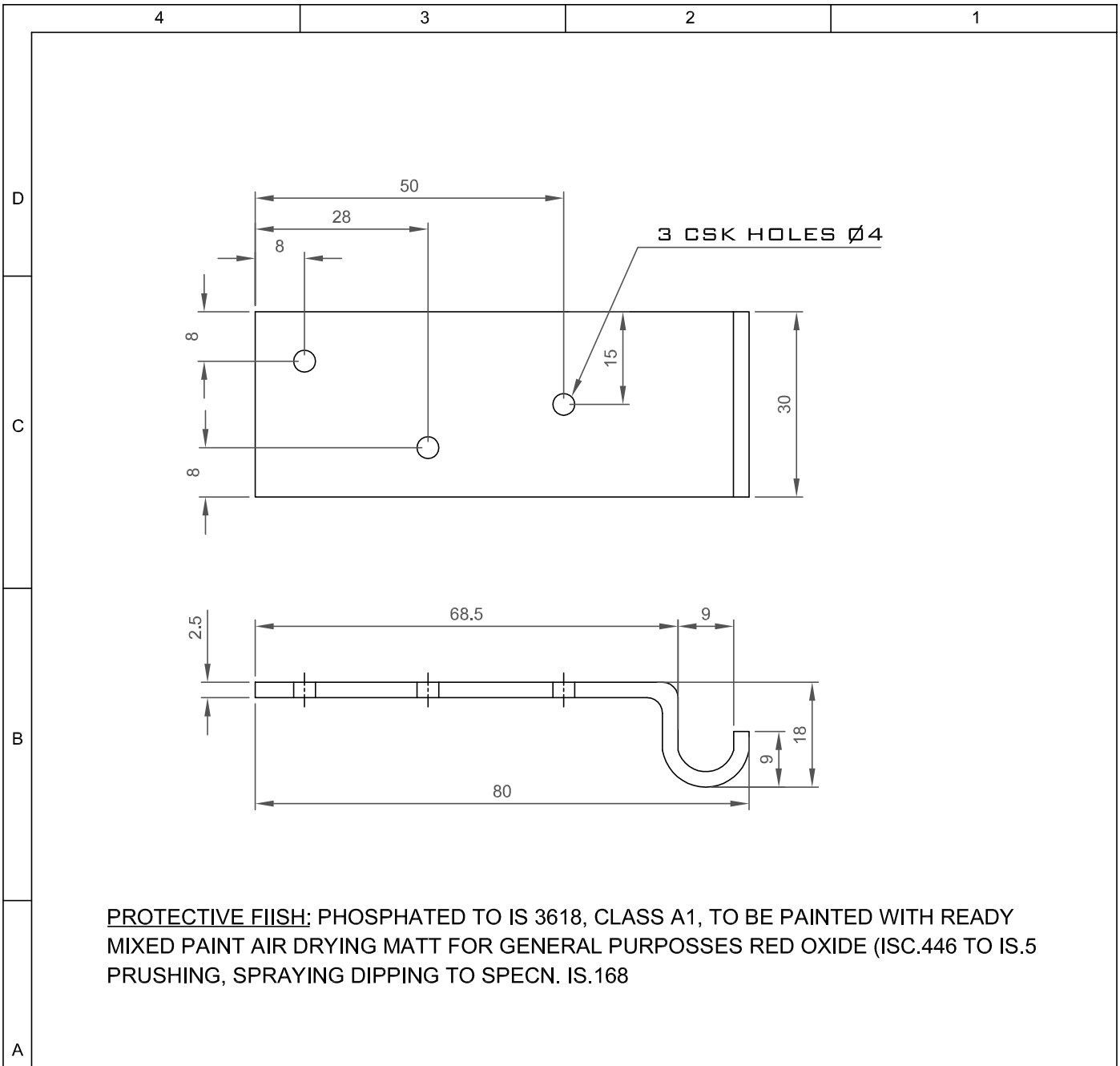

**PROTECTIVE FIISH:** PHOSPHATED TO IS 3618, CLASS A1, TO BE PAINTED WITH READY MIXED PAINT AIR DRYING MATT FOR GENERAL PURPOSES RED OXIDE (ISC.446 TO IS.5 PRUSHING, SPRAYING DIPPING TO SPECN. IS.168

R No.		DATE	ZONE	BRIEF RECORD			AUTHORITY	INITIALS		
SCALE :- 1:1		TOL.	DIMENSIONS ARE IN mm					<b>NAVAL ARMAMENT INSPECTORATE JABALPUR</b>		
DGN	DRN	TCD.	COMP	CHD						
PASSED			APPROVED							
SINA			PINA							
MATL:- STEEL				GEN. SPECN. NA-SPEC. A31-B						
MATL:- SPECN :- IS.1570-61				STORE SPECN.						
C-15				STORE REF. No.						
PROTECTIVE FINISH-SEE DRG								DRG.No.		
TITLE				<h1 style="text-align: center;">LOCKING HOOK</h1>				<h2 style="text-align: center;">NAI(J) 245/1/1</h2> <p style="text-align: center;">(PROVISIONAL)</p>		

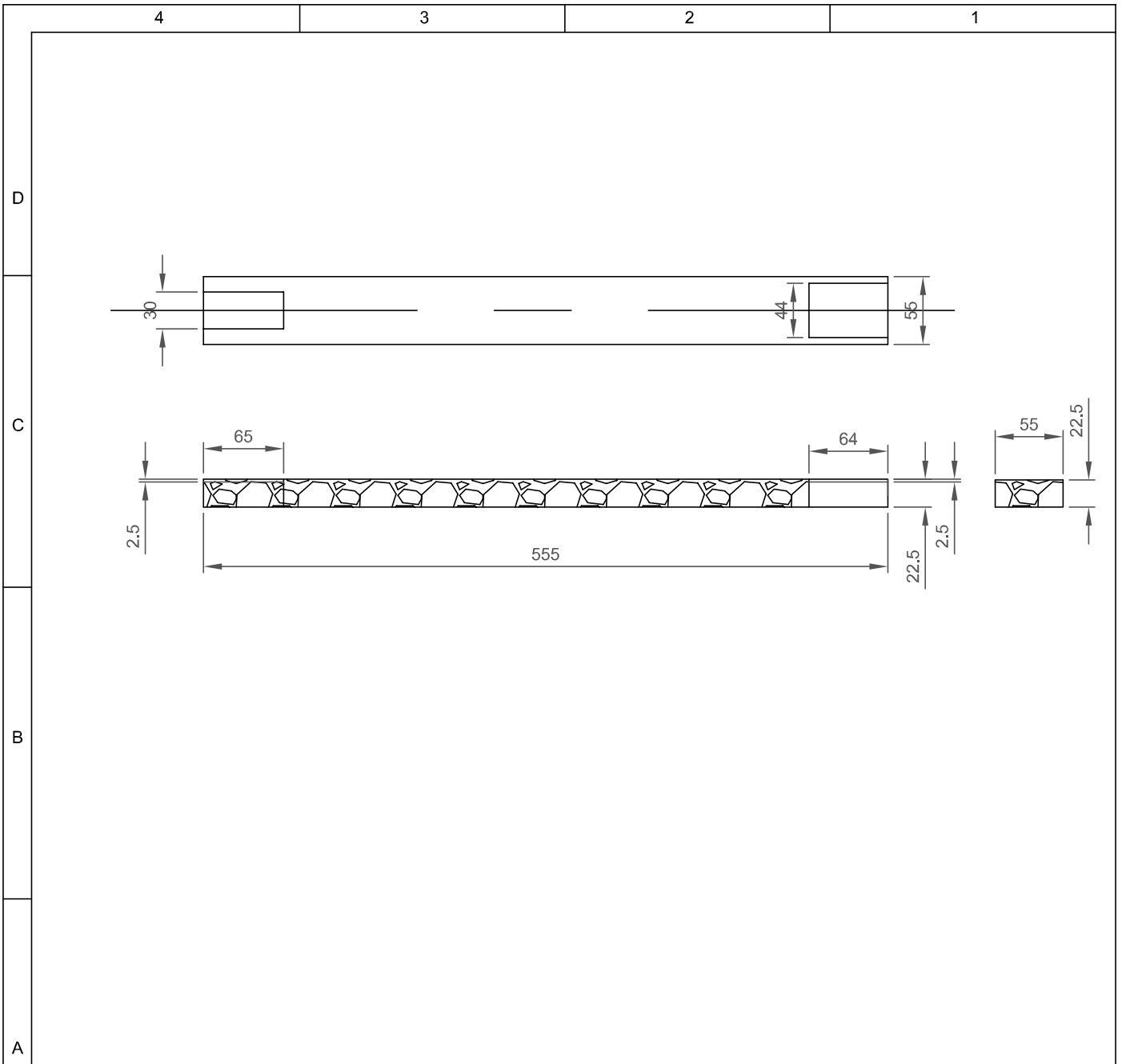

	11.11.04						
R No.	DATE	ZONE	BRIEF RECORD			AUTHORITY	INITIALS
SCALE :-1:1		TOL.	DIMENSIONS ARE IN mm				
DGN	DRN	TCD.	COMP	CHD	<b>NAVAL ARMAMENT INSPECTORATE JABALPUR</b>		
PASSED		APPROVED					
SINA		PINA					
MATL:- SPOT WOOD		GEN. SPECN. NA-SPEC. A31-B					
MATL:- SPECN :- IA.948		STORE SPECN.					
		STORE REF. No.					
PROTECTIVE FINISH-SEE DRG							
TITLE					DRG.No.		
<b><u>LID BATTEN</u></b>					<b>NAI(J) 245/1/2</b> (PROVISIONAL)		



A/F-17  
A/C-19

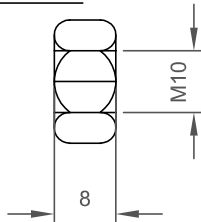

**NUT**

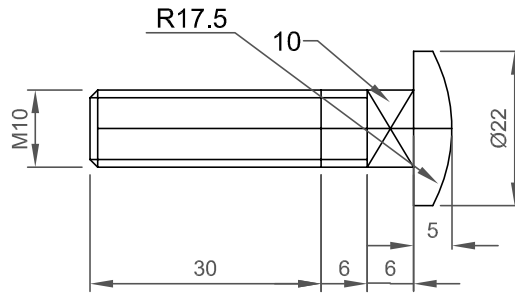

**BOLT**

**PROTECTION FINISH :** PHOSPATED TO IS 3618, CLASS, A1 TO BE PAINTED WITH READY MIXED PAINT AIR DRYING MATT FOR GENERAL PURPOSES RED OXIDE (ISC.445 TO IS.5) PRUSHING, SPRAYING DIPPING TO SPECN IS 168.

R No.		DATE	ZONE	BRIEF RECORD			AUTHORITY	INITIALS		
SCALE :- 1:1		TOL.	DIMENSIONS ARE IN mm					<b>NAVAL ARMAMENT INSPECTORATE JABALPUR</b>		
DGN	DRN	TCD.	COMP	CHD						
PASSED			APPROVED							
SINA			PINA							
MATL:- STEEL			GEN. SPECN. NA-SPEC. A31-B							
MATL:- SPECN :- IS.1570-61, C-15			STORE SPECN.							
PROTECTIVE FINISH-SEE DRG			STORE REF. No.							
TITAL							DRG.No.			
<b><u>NUT AND BOLT</u></b>							<b>NAI(J) 245/3</b> (PROVISIONAL)			

8

7

6

5

4

3

2

1

### SCHEDULE OF COMPONENTS

ITAM NO.	NOMENCLATURE	DRAWING NO.	QTY.	REMARKS
1	PLATE - I	NAI(J) 245/4/1	1	
2	PLATE - II	NAI(J) 245/4/2	1	
3	RIVET	NAI(J) 245/4/3	1	
4	HOOK	NAI(J) 245/4/4	1	

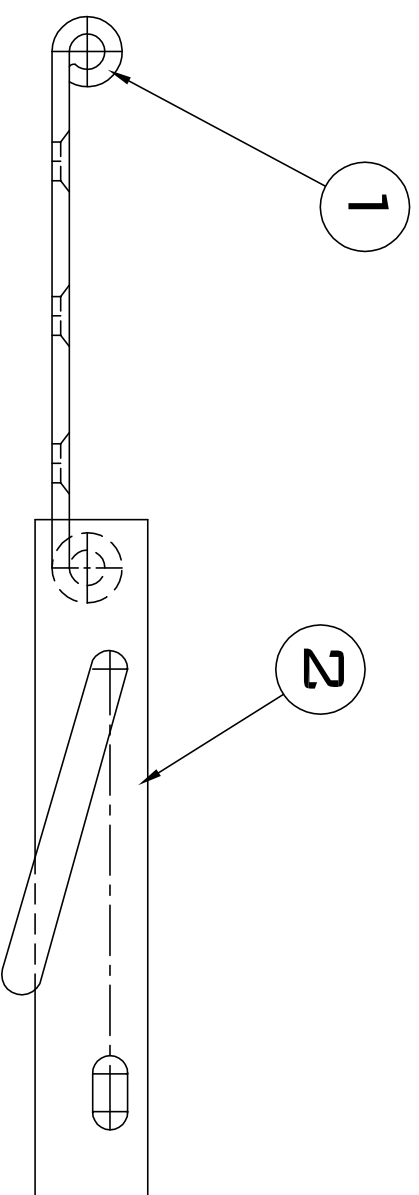
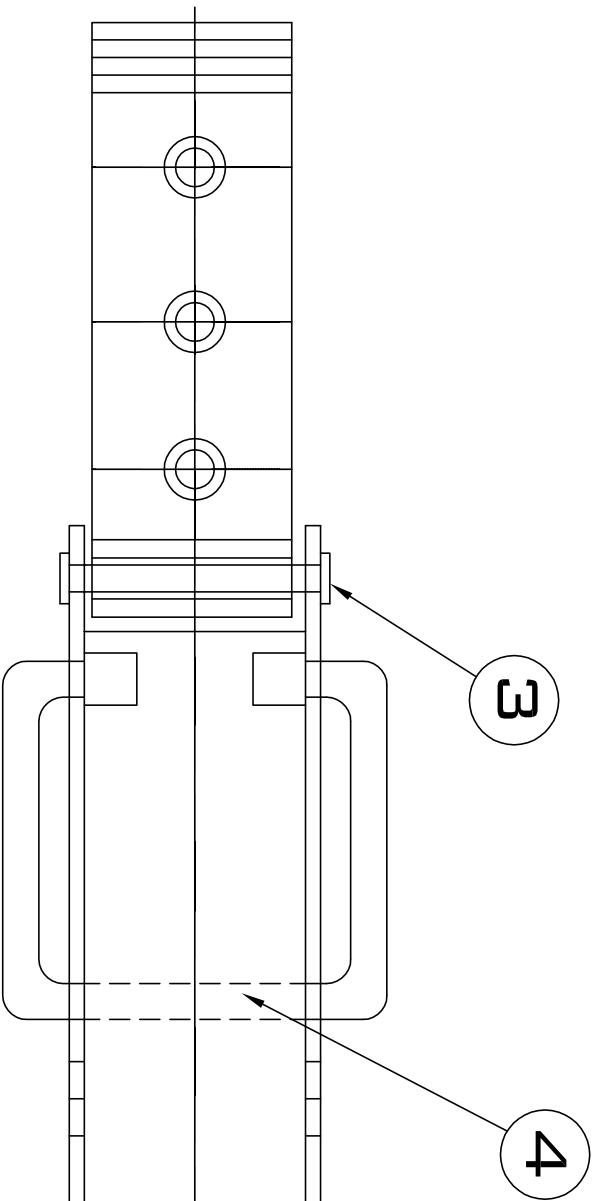

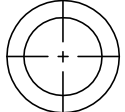
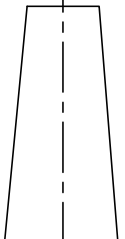
<table border="1"> <thead> <tr> <th colspan="2">SCALE :- NTS</th> <th colspan="2">TOL</th> <th colspan="3">DIMENSIONS ARE IN mm</th> </tr> <tr> <td>DGN</td> <td></td> <td>DGN</td> <td></td> <td>TCD</td> <td>COMP</td> <td>CHD.</td> </tr> </thead> <tbody> <tr> <td>PASSED</td> <td></td> <td></td> <td></td> <td>APPROVED</td> <td></td> <td></td> </tr> </tbody> </table>										SCALE :- NTS		TOL		DIMENSIONS ARE IN mm			DGN		DGN		TCD	COMP	CHD.	PASSED				APPROVED			<b>ASSY DRG. No.</b> NAVAL ARMAMENT INSPECTORATE JABALPUR	
SCALE :- NTS		TOL		DIMENSIONS ARE IN mm																												
DGN		DGN		TCD	COMP	CHD.																										
PASSED				APPROVED																												
<b>MATL.:-</b> MATL. SPEC:- PROTECTIVE FINISH:-		<b>MATL.:-</b> SINA GEN SPEC NA SPEC A31-B STORE SPEC STORE REF. No.		<b>FOR PINA</b>																												
R.No.	DATE	ZONE	BRIF RECORD	AUTHORITY	INITIALS																											
	11-11-04		APPROVED																													

## CATCH LOCKING ASSEMBLY

DRG.No.

NAI(J) 245/4

(PROVISIONAL)



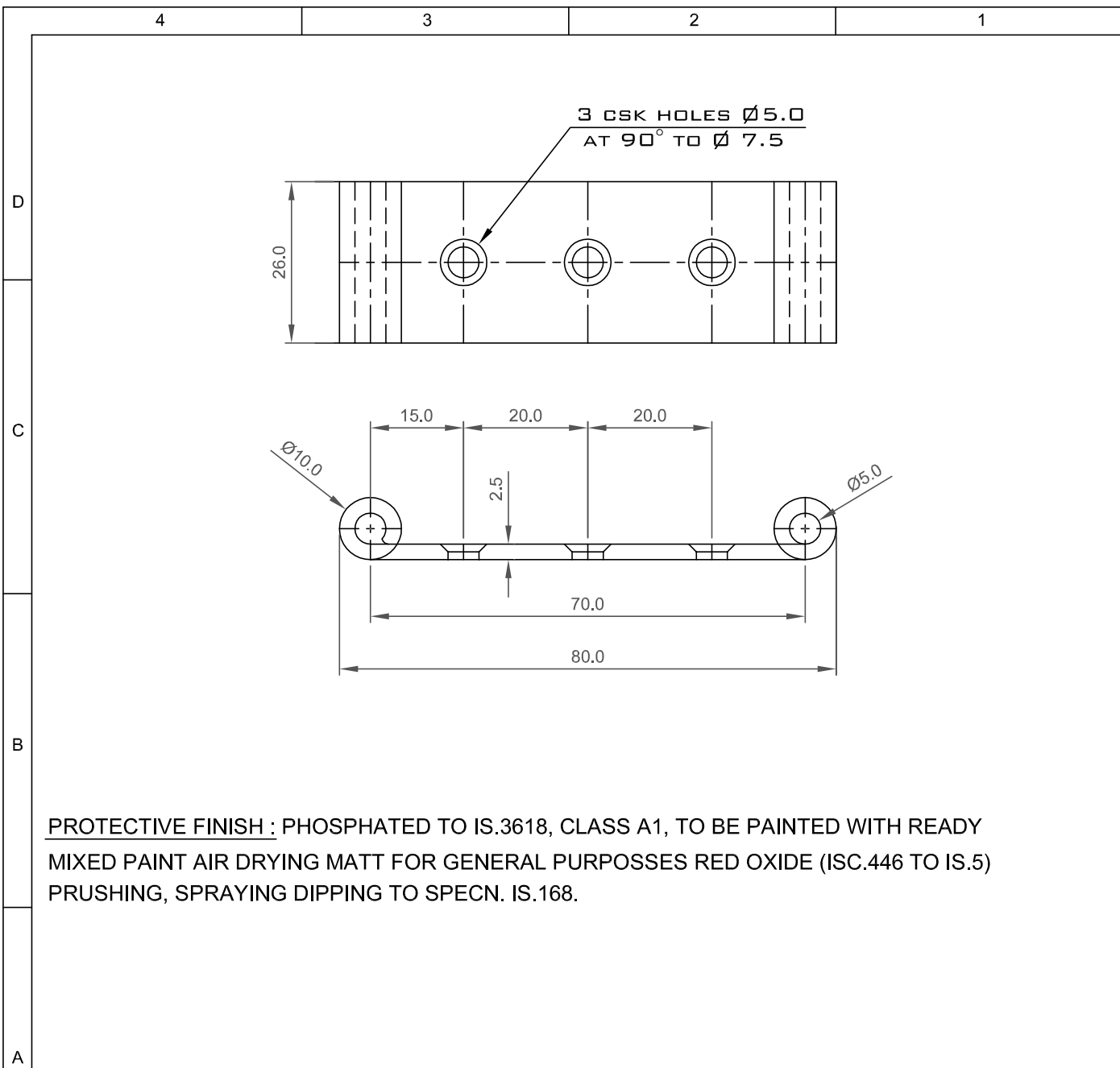

PROTECTIVE FINISH : PHOSPHATED TO IS.3618, CLASS A1, TO BE PAINTED WITH READY MIXED PAINT AIR DRYING MATT FOR GENERAL PURPOSES RED OXIDE (ISC.446 TO IS.5) PRUSHING, SPRAYING DIPPING TO SPECN. IS.168.

R No.		DATE	ZONE	BRIEF RECORD			AUTHORITY	INITIALS			
SCALE :-		TOL.	DIMENSIONS ARE IN mm					<b>NAVAL ARMAMENT INSPECTORATE JABALPUR</b>			
DGN	DRN	TCD.	COMP	CHD	PASSED		APPROVED				
SINA			FOR PINA			MATERIAL					
MATERIAL :- STEEL			GEN. SPECN. NA-SPEC. A31-B			MATERIAL :- SPECN :- IS.1570-61, C-15					
PROTECTIVE FINISH-SEE DRG			STORE SPECN.			STORE REF. No.		NAI(J) 245/4/1			
TITAL		<b>PLATE-I</b>					(PROVISIONAL)				

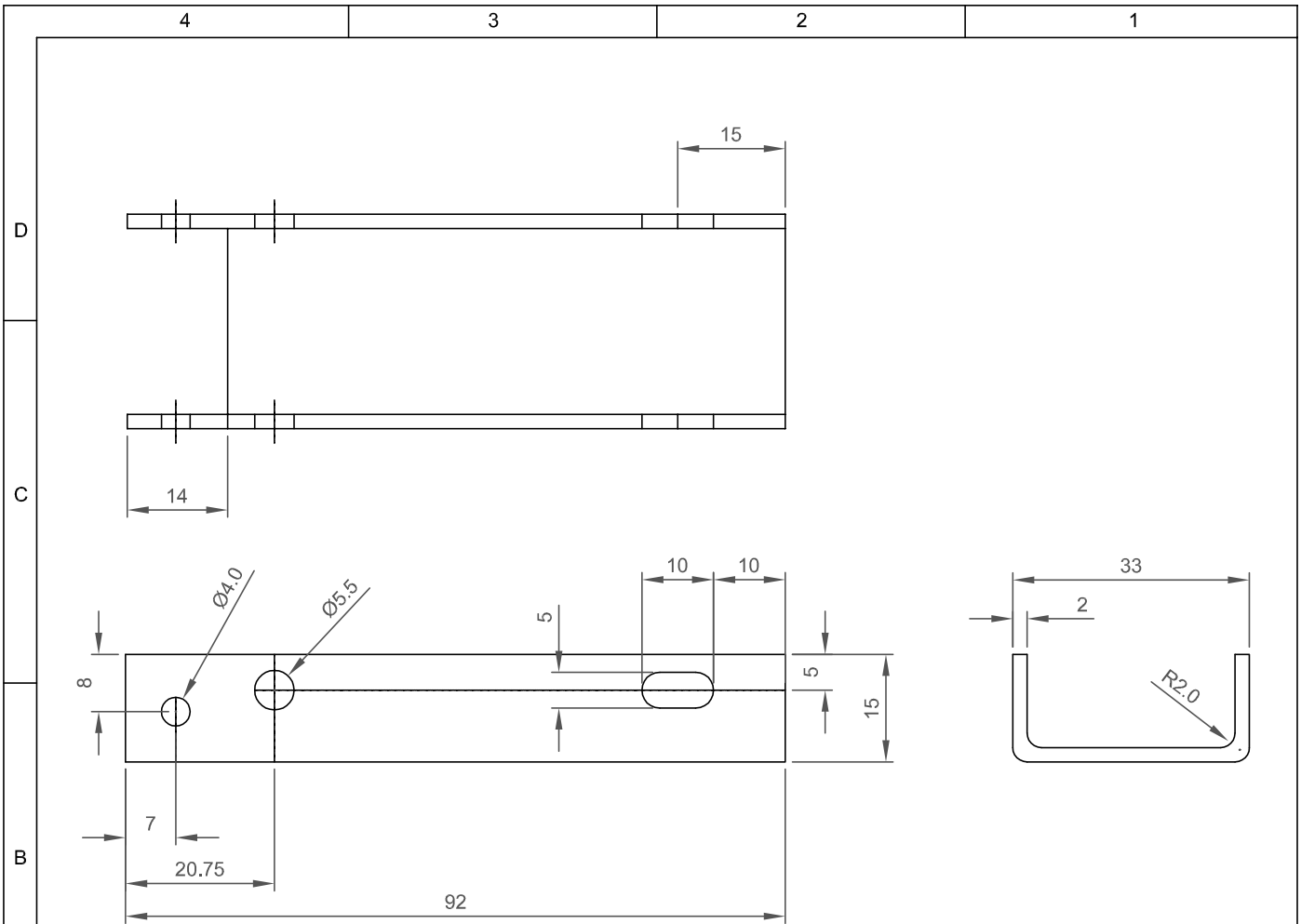

PROTECTIVE FINISH : PHOSPATED TO IS.3618, CLASS A1, TO BE PAINTED WITH READY MIXED PAINT AIR DRYING MATT FOR GENERAL PURPOSES RED OXIDE (ISC.446 TO IS.5) PRUSHING, SPRAYING DIPPING TO SPECN. IS.168.

R No.		DATE	ZONE	BRIEF RECORD			AUTHORITY	INITIALS		
SCALE :-		TOL.	DIMENSIONS ARE IN mm					<b>NAVAL ARMAMENT INSPECTORATE JABALPUR</b>		
DGN	DRN	TCD.	COMP	CHD						
PASSED			APPROVED							
SINA			PINA							
MATL:- STEEL				GEN. SPECN. NA-SPEC. A31-B						
MATL:- SPECN :- IS.1570-61, C-15				STORE SPECN.						
PROTECTIVE FINISH-SEE DRG				STORE REF. No.						
TITAL							DRG.No.			
<b><u>PLATE-II</u></b>							<b>NAI(J) 245/4/2</b> (PROVISIONAL)			

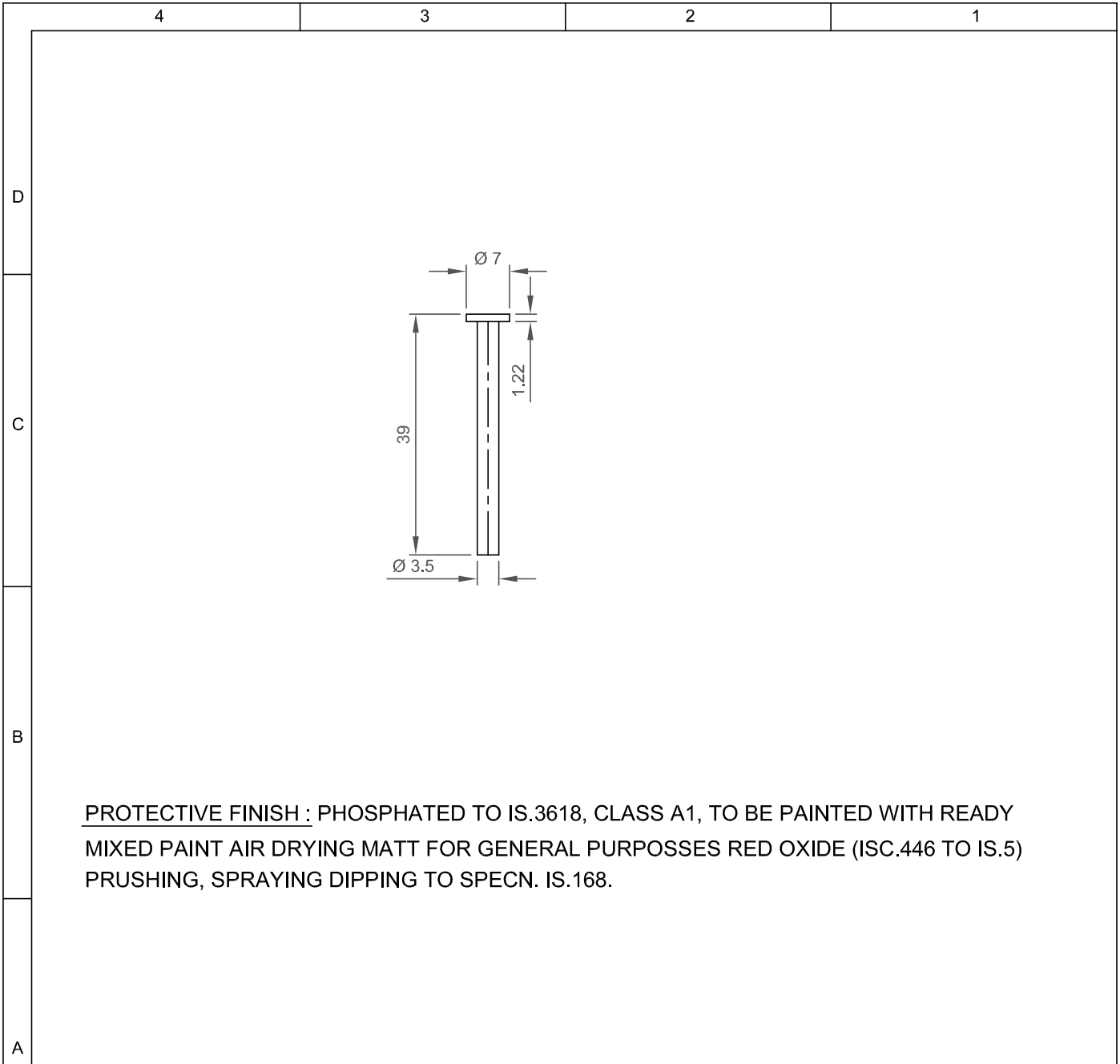

PROTECTIVE FINISH : PHOSPHATED TO IS.3618, CLASS A1, TO BE PAINTED WITH READY MIXED PAINT AIR DRYING MATT FOR GENERAL PURPOSES RED OXIDE (ISC.446 TO IS.5) PRUSHING, SPRAYING DIPPING TO SPECN. IS.168.

				APPROVED			
R No.	DATE	ZONE	BRIEF RECORD			AUTHORITY	INITIALS
SCALE :-		TOL.	DIMENSIONS ARE IN mm				
DGN	DRN	TCD.	COMP	CHD			
PASSED			APPROVED				
SINA			PINA				
MATL:- STEEL			GEN. SPECN. NA-SPEC. A31-B				
MATL:- SPECN :- IS.1570-61, GRADE 'O'			STORE SPECN.				
			STORE REF. No.				
PROTECTIVE FINISH-SEE DRG							
TITAL			<b><u>RIVET</u></b>				
						DRG.No.	
						<b>NAI(J) 245/4/3</b>	
						(PROVISIONAL)	



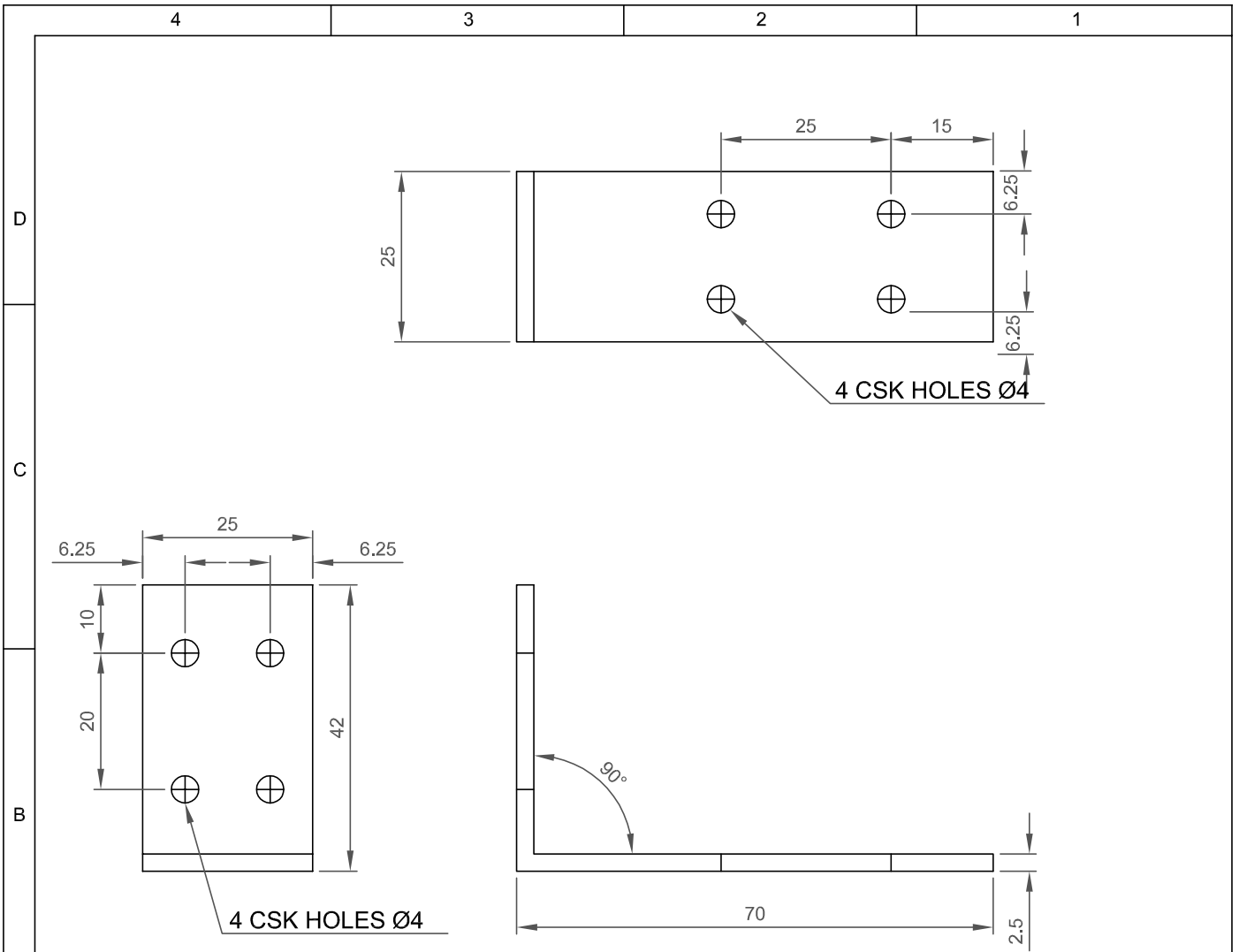

**PROTECTIVE FINISH :** PHOSPHATED TO IS.3618, CLASS A1, TO BE PAINTED WITH READY MIXED PAINT AIR DRYING MATT FOR GENERAL PURPOSES RED OXIDE (ISC.446 TO IS.5) PRUSHING, SPRAYING DIPPING TO SPECN. IS.168.

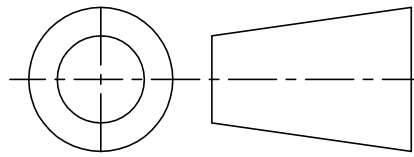
R No.		DATE	ZONE	APPROVED BRIEF RECORD			AUTHORITY	INITIALS
SCALE :- 1 : 1		TOL.		DIMENSIONS ARE IN mm				<b>NAVAL ARMAMENT INSPECTORATE JABALPUR</b>  
DGN	DRN	TCD.	COMP	CHD				
PASSED SINA			APPROVED PINA					
MATL:- STEEL			GEN. SPECN. NA-SPEC. A31-B					
MATL:- SPECN :- IS.1570-61, C-15			STORE SPECN. STORE REF. No.					
PROTECTIVE FINISH-SEE DRG								
TITAL								
<b>ANGLE STRIP</b>							DRG.No.	NAI(J) 245/5 (PROVISIONAL)

PROTECTIVE FINISH : PHOSPHATED TO IS.3618, CLASS A1, TO BE PAINTED WITH READY MIXED PAINT AIR DRYING MATT FOR GENERAL PURPOSES RED OXIDE (ISC.446 TO IS.5) PRUSHING, SPRAYING DIPPING TO SPECN. IS.168.

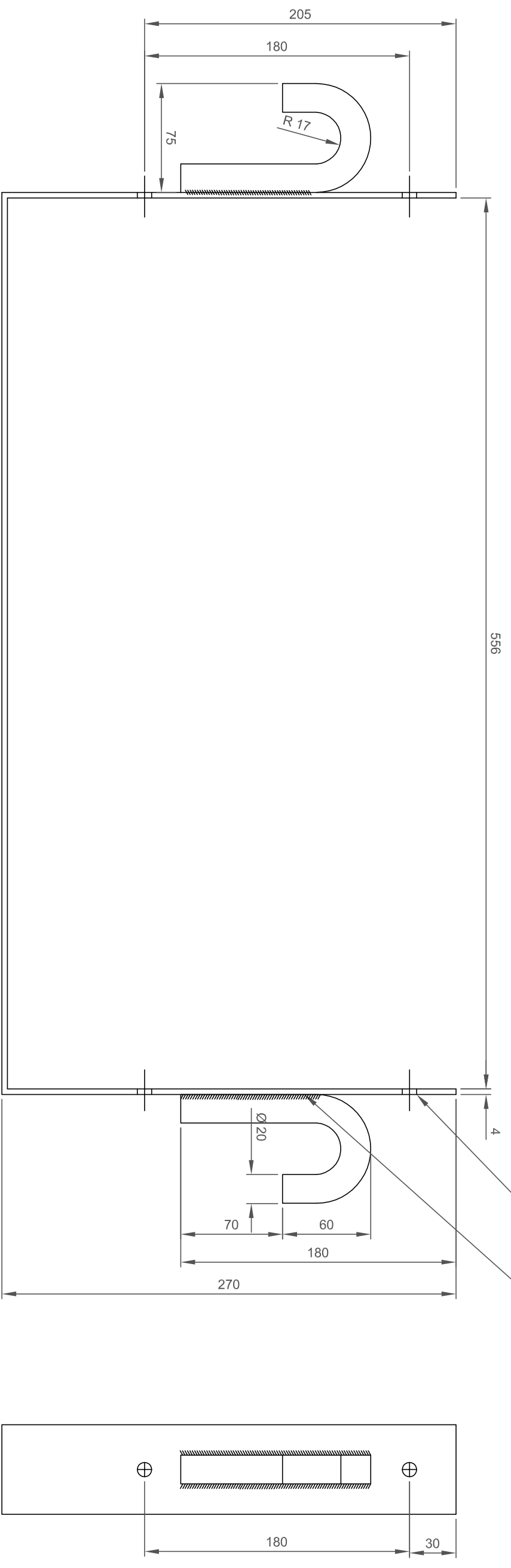
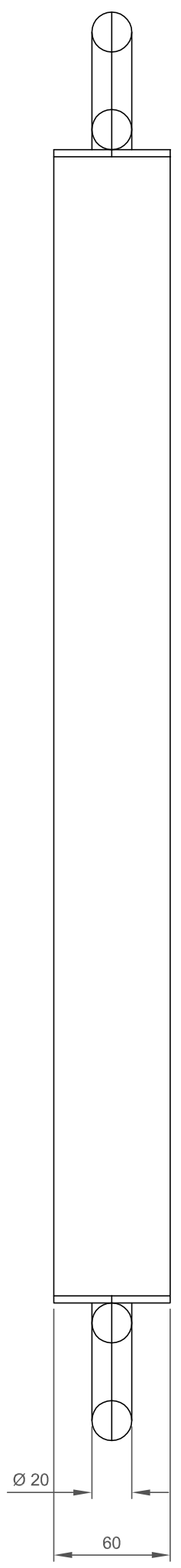

SCALE :- NTS		TOL		DIMENSIONS ARE IN mm		
DGN	DRN	TCD	COMP	CHD.		
PASSED		SINA		APPROVED		PINA
MATL.:-STEEL		GEN SPEC NA SPEC A31-B		STORE SPEC		STORE REF. No.
MATL. SPEC:- IS:1570-61,C-15		PROTECTIVE FINISH:-SEE DRG.				
R.No.	DATE	ZONE	BRIEF RECORD	AUTHORITY	INITIALS	
	11.11.04		APPROVED			

# HOOK STRIP

NAVAL ARMAMENT  
INSPECTORATE  
JABALPUR

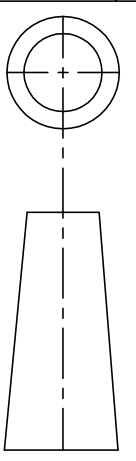

DRG.No.

NAI(J) 245/6  
(PROVISIONAL)

ASSY DRG. No. NAI(J) 245(P)

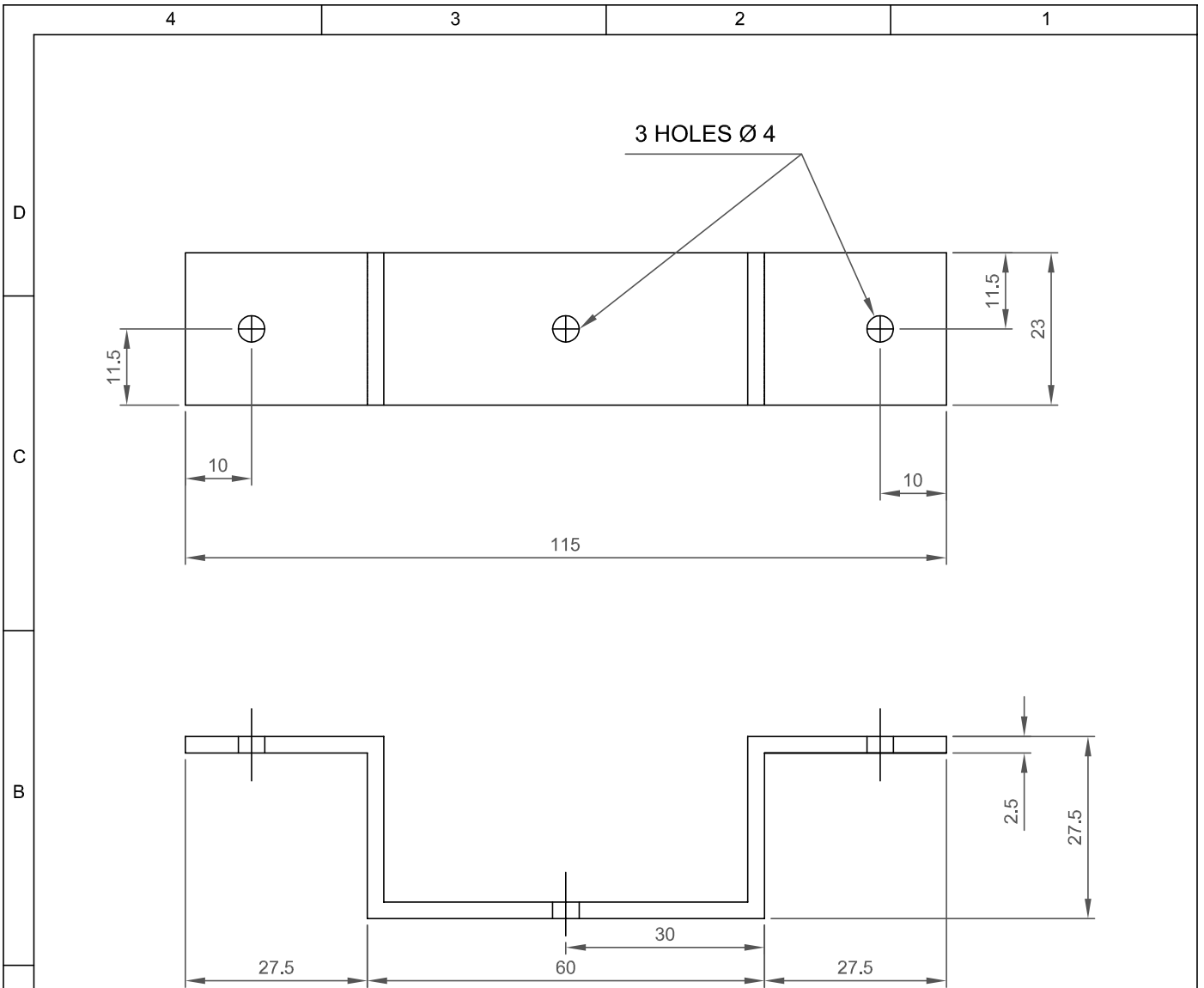

**PROTECTIVE FINISH :** PHOSPHATED TO IS.3618, CLASS A1, TO BE PAINTED WITH READY MIXED PAINT AIR DRYING MATT FOR GENERAL PURPOSES RED OXIDE (ISC.446 TO IS.5) PRUSHING, SPRAYING, DIPPING TO SPECN. IS.168.

R No.		DATE	ZONE	BRIEF RECORD			AUTHORITY	INITIALS		
SCALE :- 1 : 1		TOL.	DIMENSIONS ARE IN mm					<b>NAVAL ARMAMENT INSPECTORATE JABALPUR</b>		
DGN	DRN	TCD.	COMP	CHD						
PASSED			APPROVED							
SINA			PINA							
MATL:- STEEL				GEN. SPECN. NA-SPEC. A31-B						
MATL:- SPECN :- IS.1570-61, C-15				STORE SPECN.						
PROTECTIVE FINISH-SEE DRG				STORE REF. No.						
TITAL							DRG.No.			
<b><u>CLAMP</u></b>							<b>NAI(J) 245/7</b> (PROVISIONAL)			

8

7

6

5

4

3

2

1

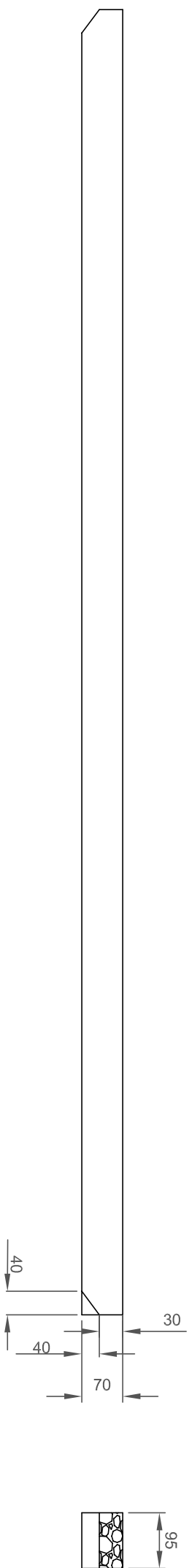
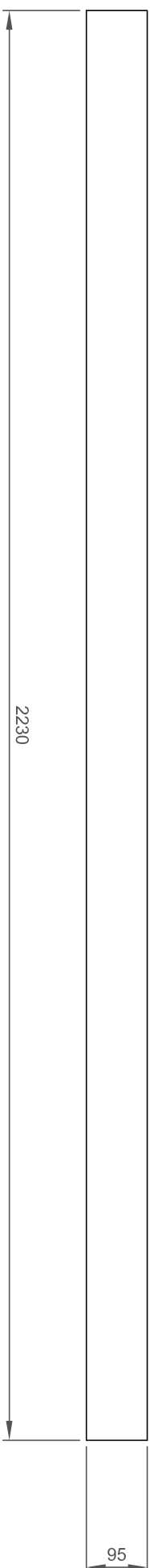

R.No.		DATE	ZONE	BRIF RECORD	AUTHORITY	INITIALS	DIMENSIONS ARE IN mm					
							SCALE :- NTS	TOL	DGN	TCD	COMP	CHD.
							DGN	DGN	PASSED	SINA	APPROVED	
				APPROVED			MATL.:- SOFT WOOD		GEN SPEC NA SPEC A31-B		PINA	
							MATL. SPEC:- IA , 948 (a-b)		STORE SPEC			
							PROTECTIVE FINISH:-		STORE REF. No.			

ASSY DRG. No. NAI(J).245(P)

NAVAL ARMAMENT  
INSPECTORATE  
JABALPUR

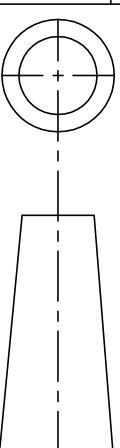

DRG.No.

NAI(J) 245/8

(PROVISIONAL)

# BASE BATTEN



