

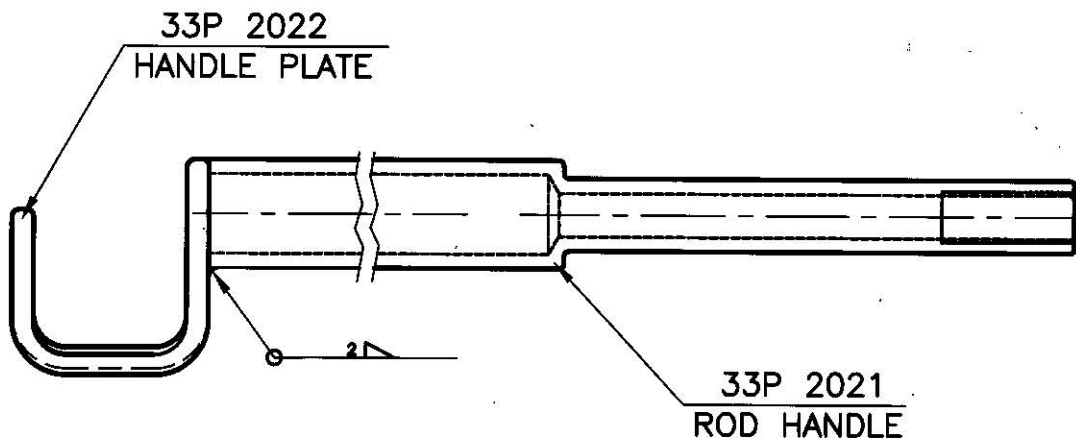

DIMENSIONS ARE IN mm.
UNTOLERATED DIMNS. AS PER IS : 2102 (MED)
SHARP CORNERS SHOULD BE BLUNT TO R 0.5

PROTECTIVE FINISH : PHOSPATED TO SPECIFICATION. JSS : 0465-01-1988
CLASS-I (ACCELERATED) OIL FINISH.

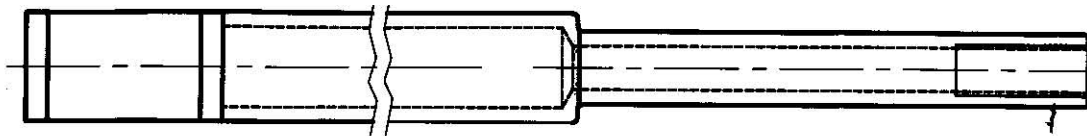

PART NO.	DESCRIPTIONS	NO OFF	MATERIAL	TREATMENT	REMARKS
	SIGNATURE & DATE.	SUB: <u>HANDLE RELEASE SUB ASSY.</u>			SCALE N.T.S
	TRACED	FOR: <u>CYLINDER GROUP</u>			STORE DRG.NO.
	DRAWN <i>S. Venkatesh</i>	OF : <u>38mm MSL</u>			OPERATION NO.
	CHECKED <i>V. V. V.</i>	DES. REF. NO.			
	HOS/D&DO <i>P. J. J.</i>	DRG. No.: <u>33P 2020</u>			
	NODAL OFFICER FOR MSL.	 ORDNANCE FACTORY TIRUCHIRAPPALLI-16.			SHEETS: 1
	OFFICER/D&DO				SHEET No.: 1
AMENDMENTS	SIG. & DATE	APPROVED ON. <u>26/09/2016</u>			