

DRAWING NUMBER  
**175.03.009-1A**

SHEET No. 1 OF 1

Rz630 ✓

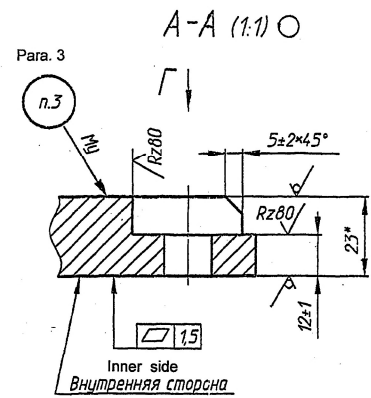
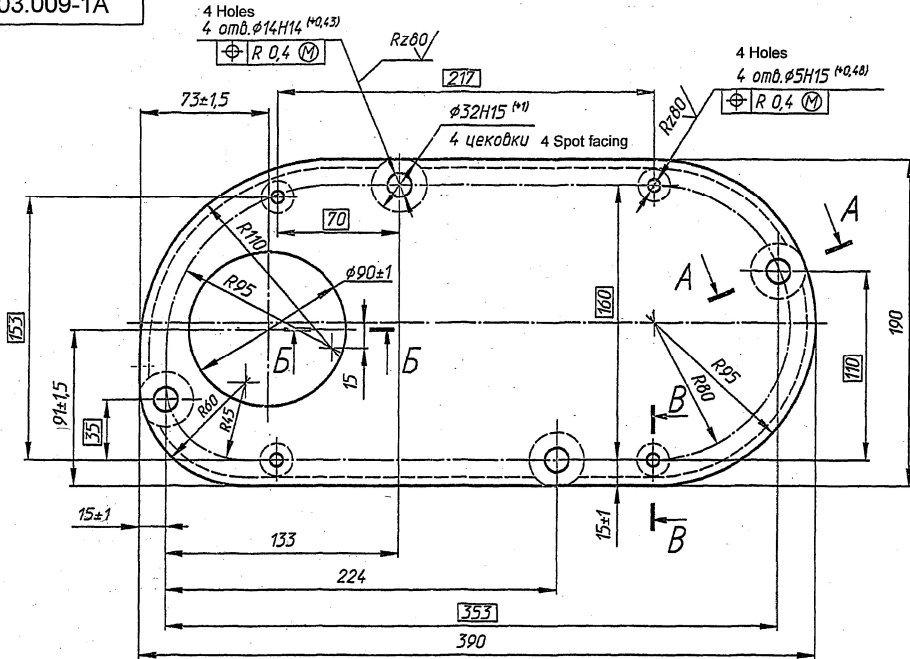

- Deviation of contour of component from gauge, made as per nominal dimension should be  $0^{+2}_{-0.5}$  mm.
- \*Dimension for reference.
- Mark the material as per GOST 2171-90 with type П10-5 GOST 2930-62.
- Coating of outer surface  
Primer B/1-02  
Primer AK - 070  
Protective Enamel XB-518  
Inner surface  
primer AK-070  
Dark - grey enamel ПФ - 223 or dark-grey ПФ - 115, 894.  
Requirement as per 520.TY5.
- Other requirements as per 520.TY1.

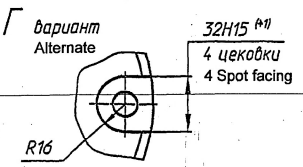
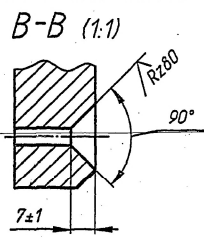
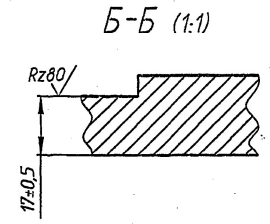

PILOT-SAMPLE SHOULD BE APPROVED BY A H S P BEFORE BULK PRODUCTION.

EST. WT. (kg) 3.9	TO BE STAMPED OR MARKED WHERE INDICATED THUS # ( LETTERS)
ALL SHARP EDGES AND CORNERS TO BE REMOVED UNLESS OTHERWISE STATED MACHINED CORNERS TO HAVE R OUT-SIDE R INSIDE EQUIVALENT CHAMFERS ARE PERMISSIBLE.	

DRN	
CHD	B. 70
APPD	Chavshel
DATE	14-10-04
SCALE	1:2
DIMENSIONS IN mm	
TOLERANCE ON DIMNS UNLESS OTHERWISE STATED IS: 2102-09	
ALL THREADS TO CONFORM TO	
ISSUE	DATE
NATURE OF AMENDMENTS	

MATERIAL:- PLATE A6T-101 T1 23 OCT B3-75-86	USED ON:- 175.03.017cb-1Cb 172.03.017cb-1Cb
CONTROLLERATE OF QUALITY ASSURANCE (HEAVY-VEHICLES) AVADI	
TITLE:- <b>ACCESS HOLE COVER</b>	
D S CAT NUMBER	DRAWING NUMBER <b>175.03.009-1A</b>

356  
SUPPLY CODE  
U-01-1-2  
D90040  
F-61  
52  
SIZE A4x3