

OFB

1 CHAMFERED 0.2x45°

DATE: 24/04/2018
 condition A compress bar shall be heat treated to achieve hardness 30-35 HRC
 QRF: CQA(W) JABALPUR LG, 162-102/COAW/011
 DL 12 JULY 2005)

JWM/CDD

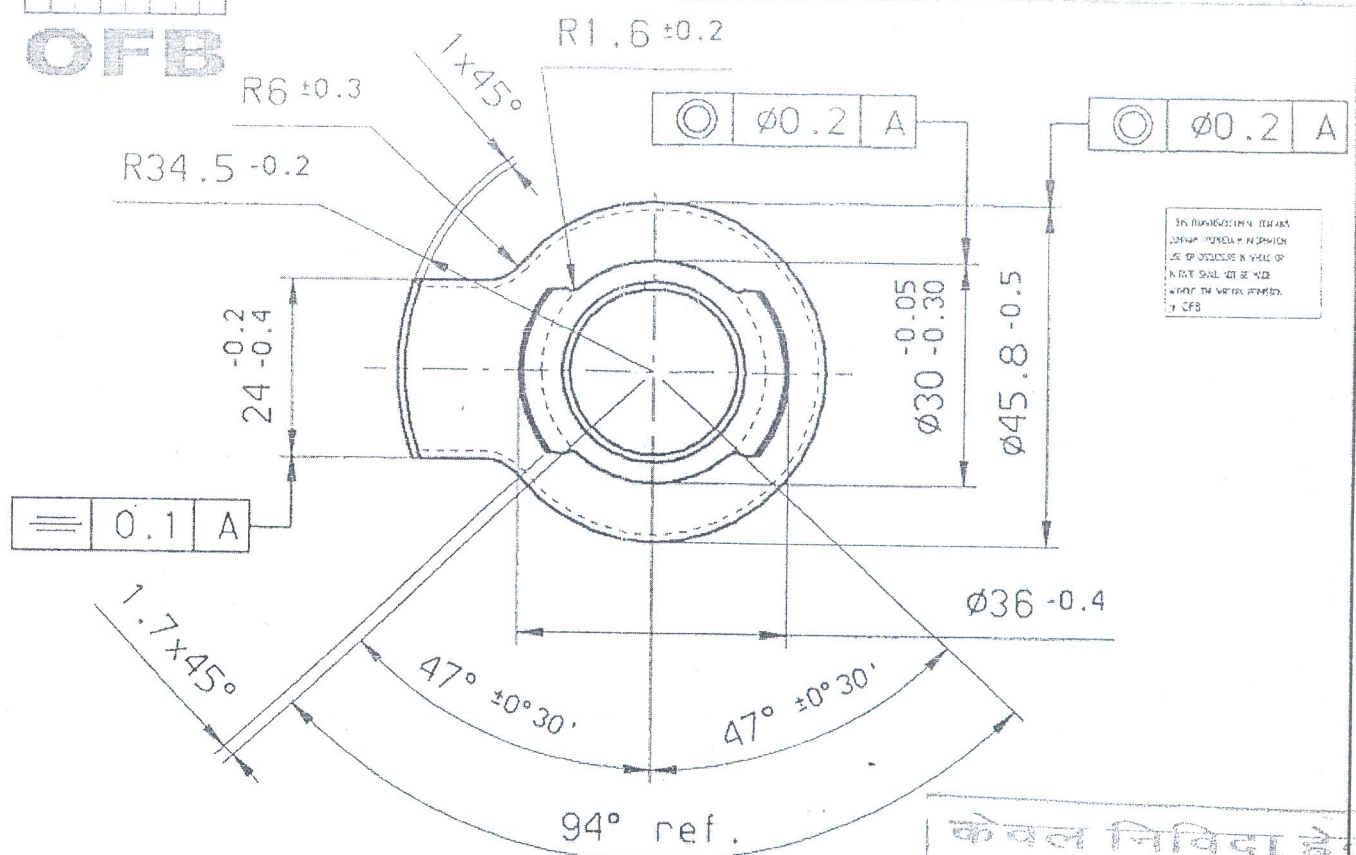

3x DIMENSIONS (RADIUS)
 DIMENSIONS (RADIUS)
 AS PER DIMENSIONS IN THIS
 DRAWING SHALL BE IN
 ACCORDANCE WITH ISIRI
 10000:2005

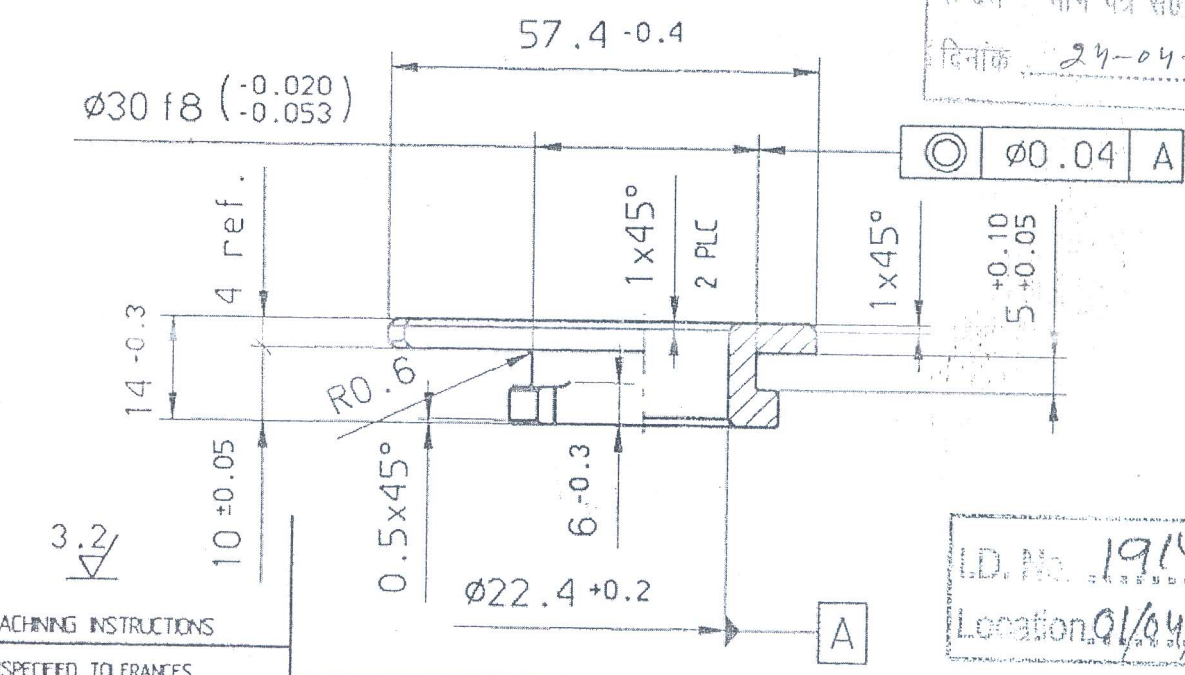

केवल निविदा हेतु
 सन्दर्भ माँग पत्र सं. 380156
 दिनांक 24-04-2018

ID. No. 1914
 Location 01/04/01-01

DRAWING SEALED BY DO COA(W)
 CQA (W), JABALPUR
 Dt: 27-5-2005

MACHINING INSTRUCTIONS

UNSPECIFIED TOLERANCES FOR DIMENSIONS AND ANGLES DIMENSIONS

ANGLES

HEAT TREATMENT

30-35 HRC

FINISH PHOSPHATE COATING ACCORDING TO DDD-P-16232 TYPE M CL 2

MATERIAL

L=20
 Round 75 DIN 1013-42CrMo4

SHARANG 130/155MM_UG_OFB_SLB

ASSEMBLY 161-466 (176-1002)

NAME

CAP

UPDATED

Sh: 1
 of: 1

1:1 A4
 SCALE SIZE

PREP'D	
CHKD	
JWM/DO	
APPROVED	
DO/DO	DIR/GDC

ORDNANCE DEVELOPMENT CENTRE, OFC, KANPUR

PART NO. 161-473