

Module	m	2,5
No. of teeth	Z	78
Standard basic rack	-	ГОСТ 13755-81
Addendum modification coefficient	X	0
Accuracy class as per GOST 1643-81	-	7-B
Basic tangent length	W	65,465 <sup>-0,151</sup> <sub>-0,221</sub>
Tooth height	h	5,625
Reference diameter	d	195
Designation of mating wheel drawing	-	AO-18.03.025

- Blank - forging.
- 43.5...51.5 HRCe.
- Dimensions are given after chrome plating.
- \* Dimensions are ensured by tool.
- \* Dimensions not in projection.
- Internal angle R 0.4 mm.
- Blunt edges R 0.6 mm.
- Limit deviation of angle between any two non adjacent holes Э and between any two non adjacent holes Ø ±5°
- Limit deviation along contour C-0.3 mm and along contour T, -0.2 mm, 7, 0.4 mm.
- Local increase of dimension A, up to dimension 0.026 mm at length up to 80 mm is permissible.
- Local surface finish  $Rz$  in holes P and on surface K as per test specimen is permissible.
- Marks on surface Б, while forming R, and on surface K are permissible as per test specimen.
- Check with magnetic flaw detector.
- Traces from tool while machining the groove A, on diameter 4 are permissible.
- Coating: Cad. 12 Phos. - acc cr. Imp adhesive БФ-4 GOST 12172-74, 1 layer, except surfaces П, Л, П, surface П - Cr 18 hard. Surface L - Cr hard 30-60. Surface P - Chem. Phos. Acc. Cr/imp adhesive БФ-4.
- Polish of sleeve П after chrome plating, check the surface finish as per test specimen.
- Absence of cad. Plating on holes Ц Э is permissible.
- Local absence of cad plating on grooves Г, and Д, is permissible.
- Absence of cad plating on portions Л, М and bulging of chrome on surfaces Ю, С, А, X are permissible.
- Complex inspection is selected as per GOST 1643-81, except checking of spot contact and is set in dependence on conditions and possibility of manufacturing factory.
- Mark the serial no. by engraving of each sleeve, starting from groove A, along arrow Д, opposite to center of sleeve with letter size PO-5 GOST 2930-62. Bending of wall while engraving is not permissible. Carry out marking in AO-18.01.010 SB.
- Mark П, H with letter size PO-5 GOST 2930-62.
- Stamp.
- \* Dimensions for visual inspection as per test specimen.
- Surface finish K, Л, П, as per test specimen.
- Local increase of Ц up to dimension 16A3a at length not more than 10 mm is permissible.
- Decrease of dimension H, up to 14.9 mm is permissible.
- Apply mark H on any tooth.
- Local increase of dimensions П, up to 26.3 mm after final machining is permissible.
- Fill the mark as per point 21 and mark H, with black enamel ПФ-115 GOST 6465-76 before preservation.

31. Coat non chrome plated sections Л and М with Chem. Phos. Acc. Cr.

First remarks  
Refer. No.  
Sign. & Date  
Alternate Inv. No.  
Duplicate Inv. No.  
Sign. & Date  
Inv. No.

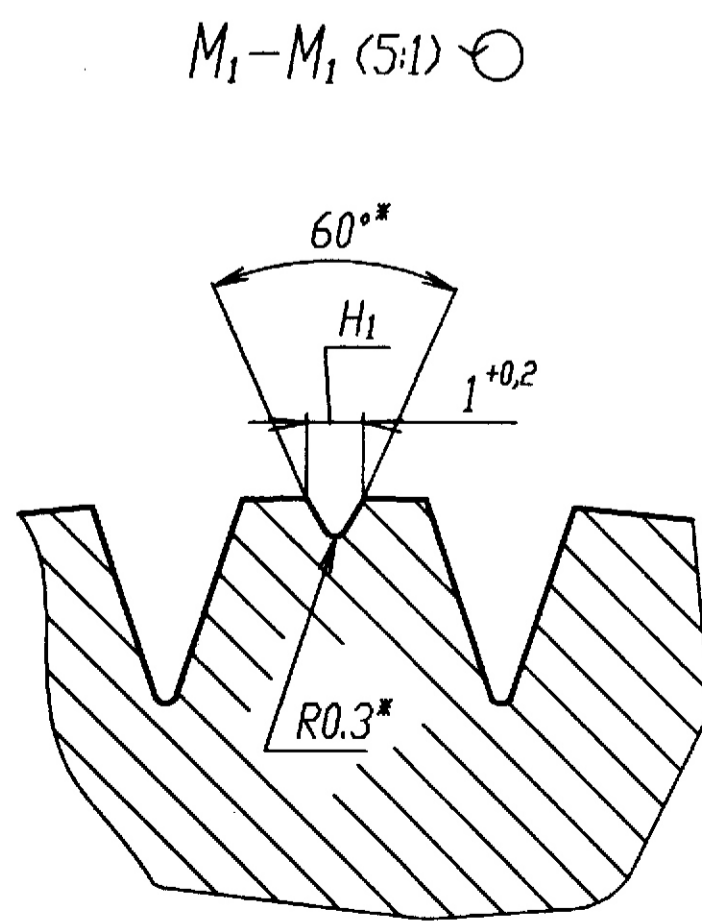

				AO-18.01.001				
Amend	Sheet	Doc. No.	Sign	Date	Type	Weight	Scale	
				Breach piece			17.7	1:1
				Sheet 1			Sheets 1	
				Steel 30XN2MFA-sh				
				OST3-98-80				

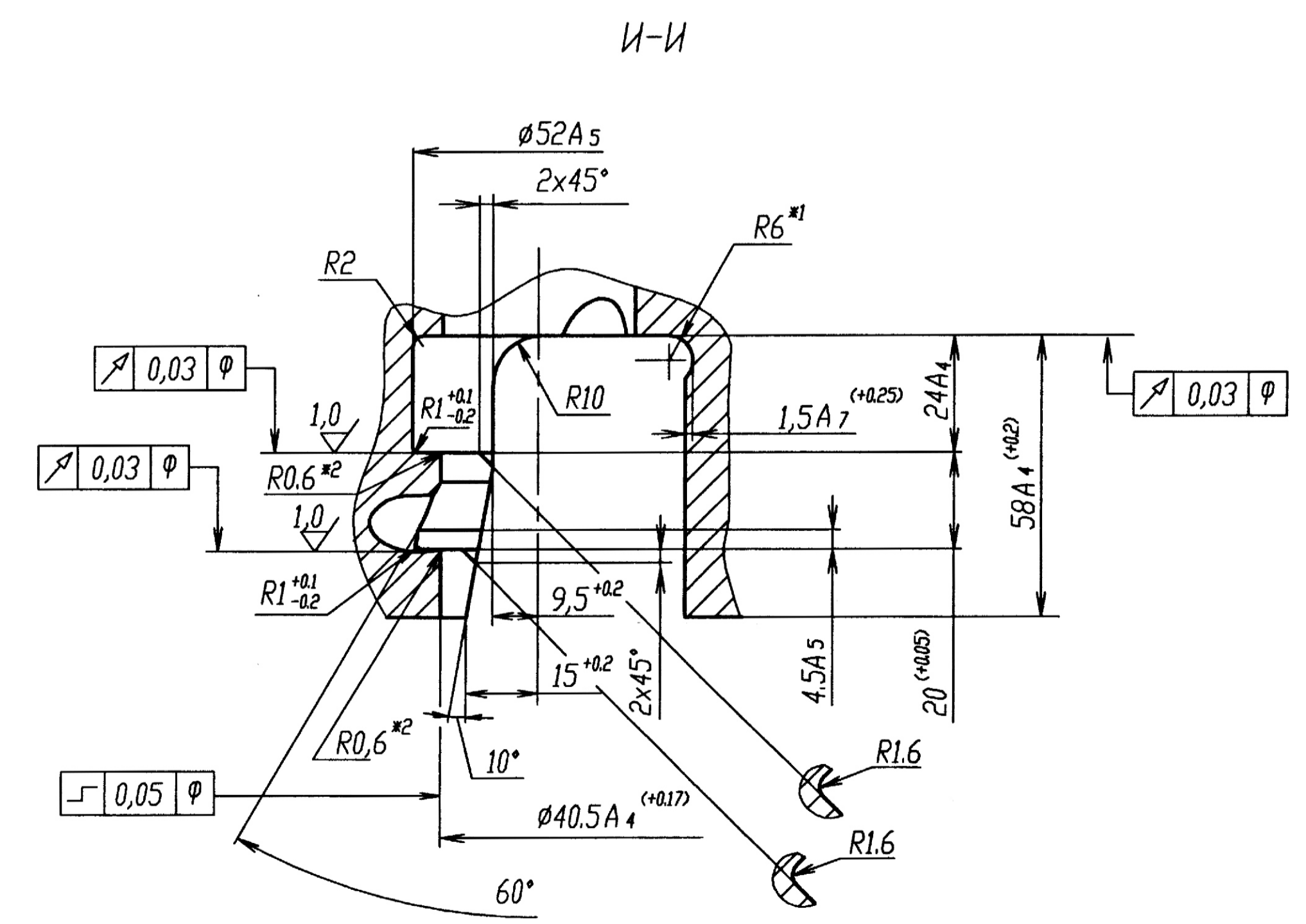
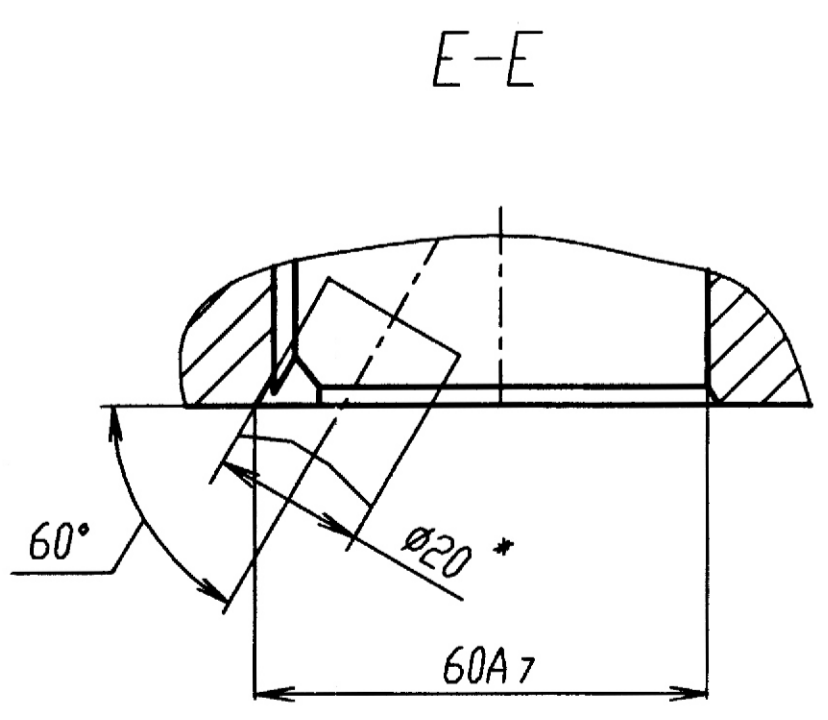
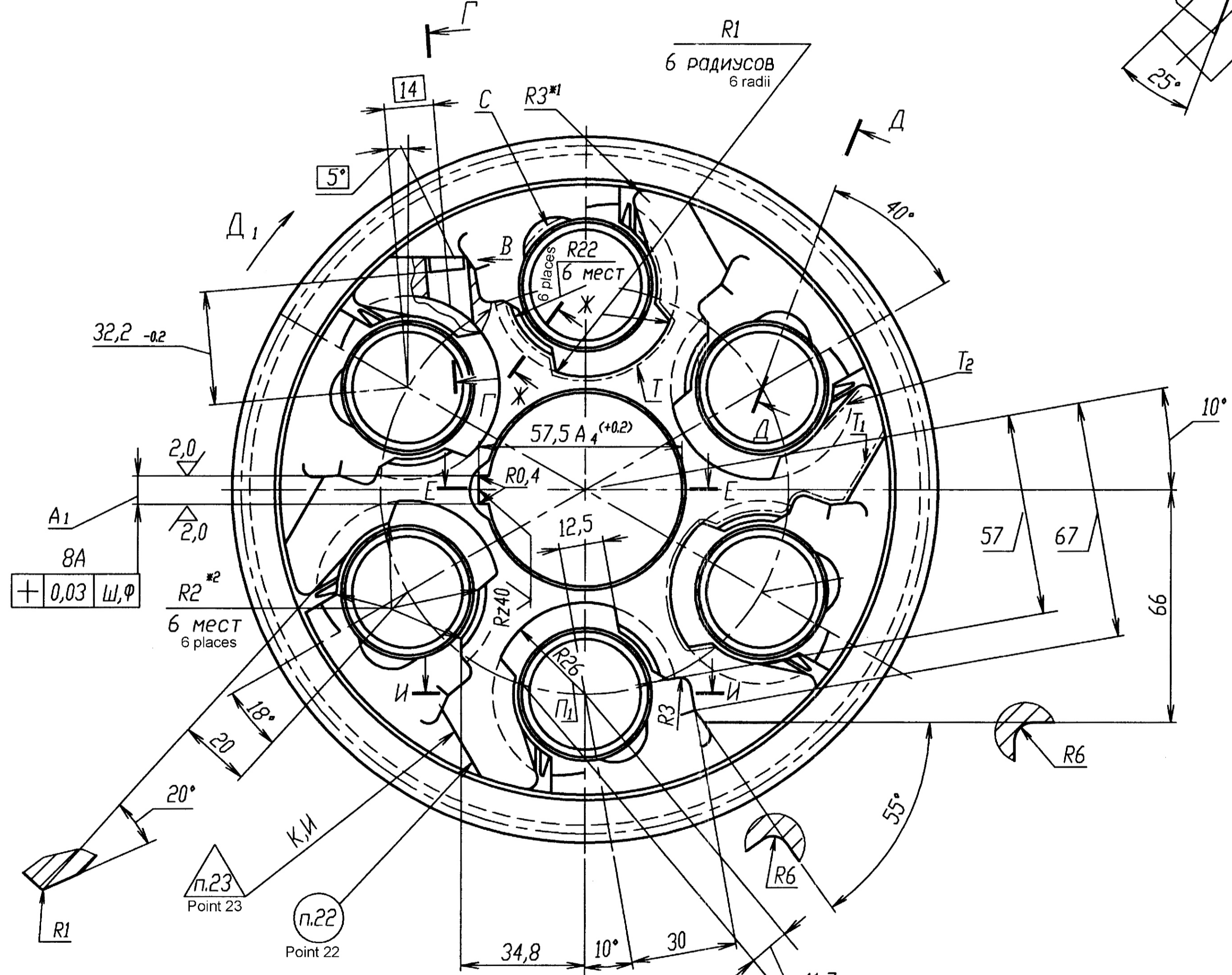
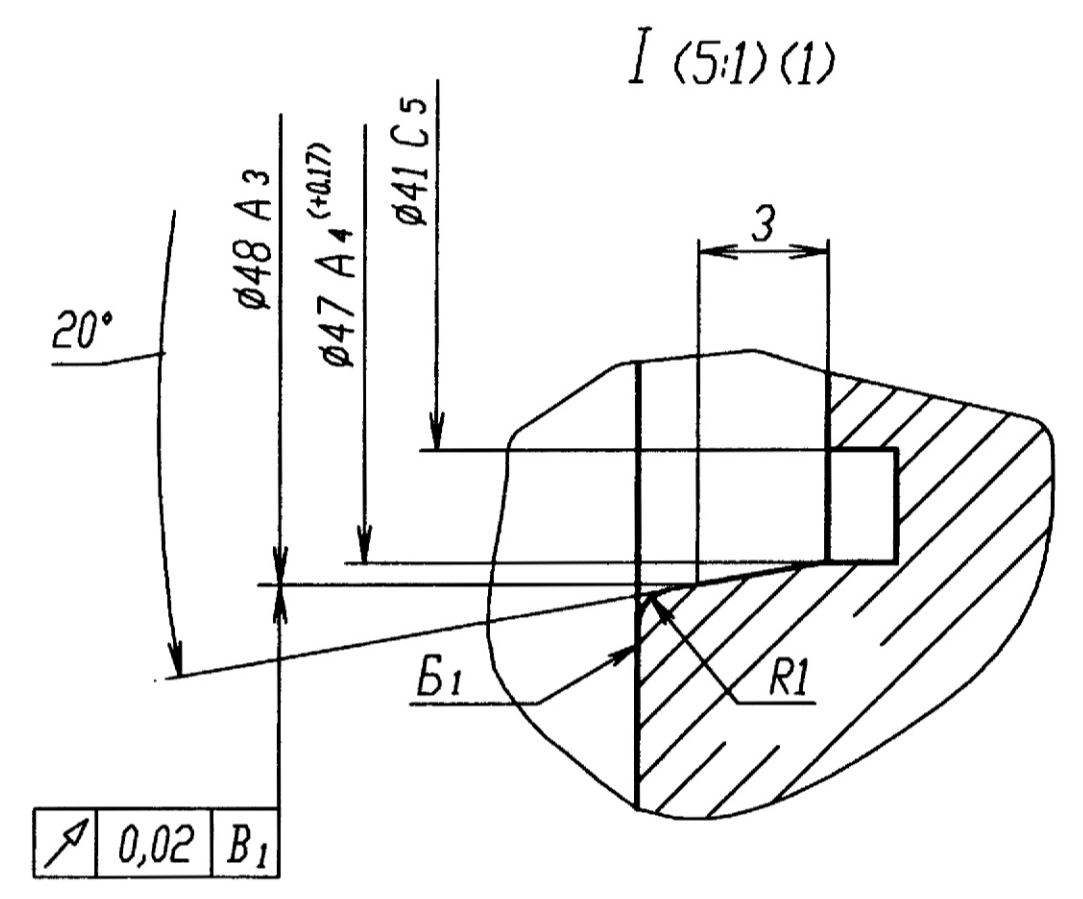
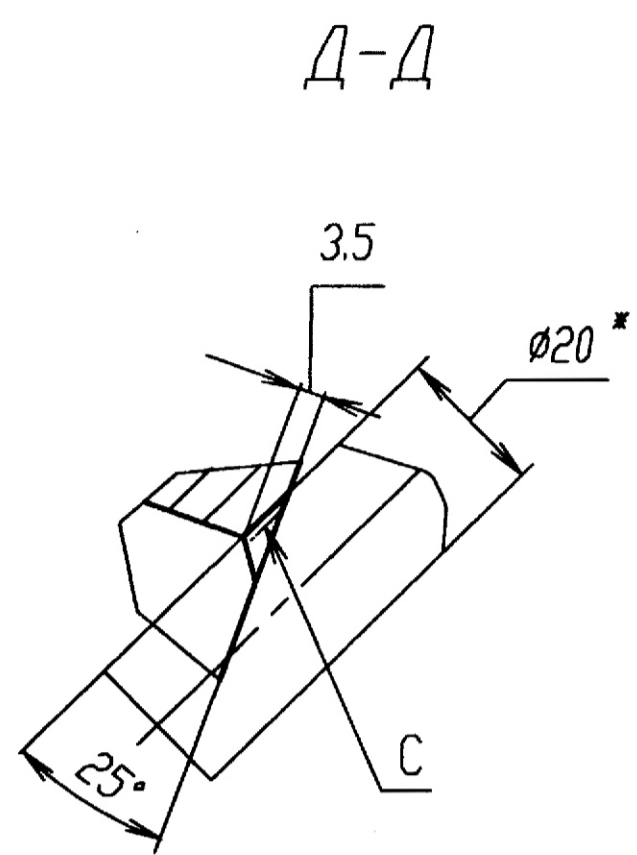
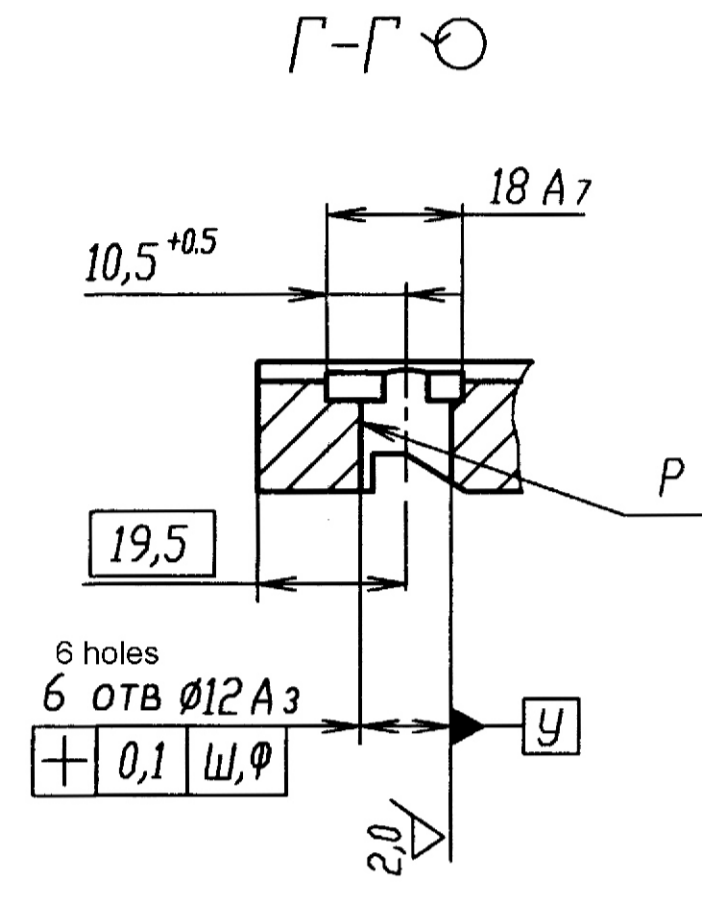
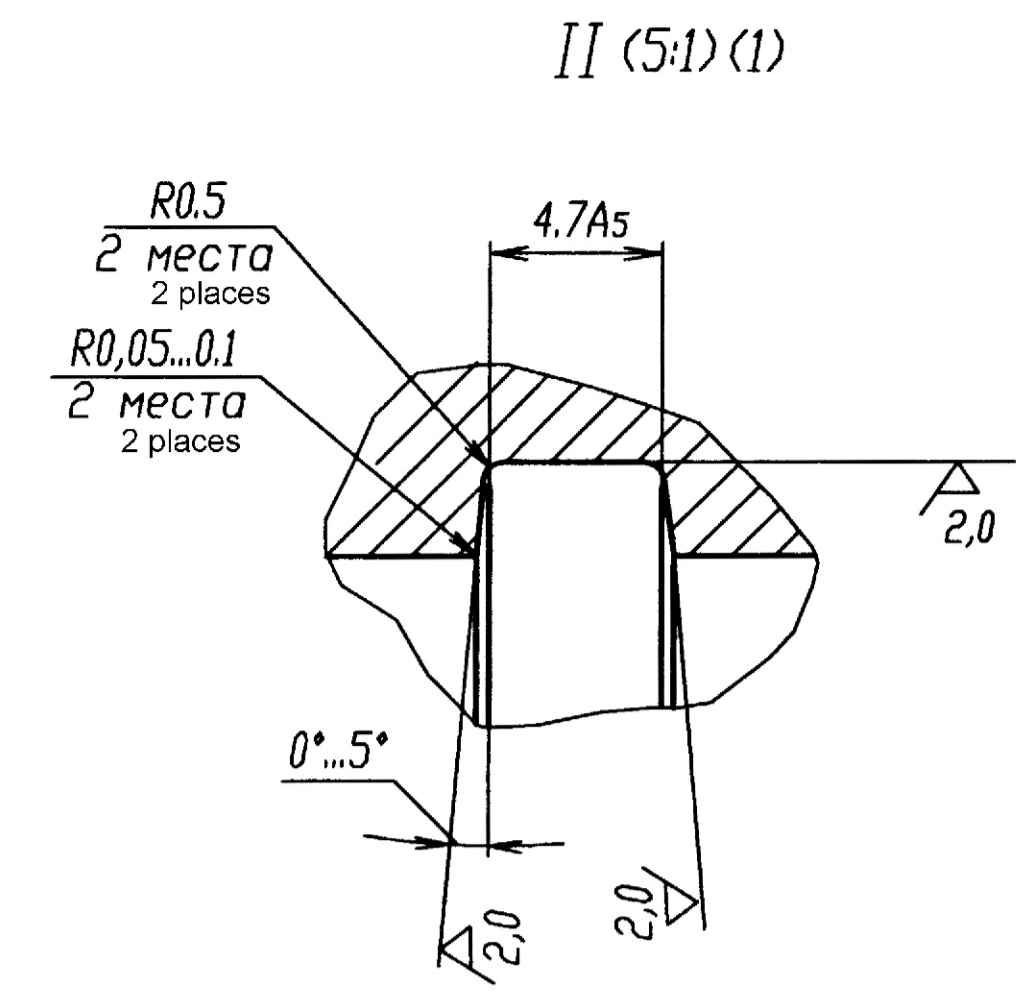
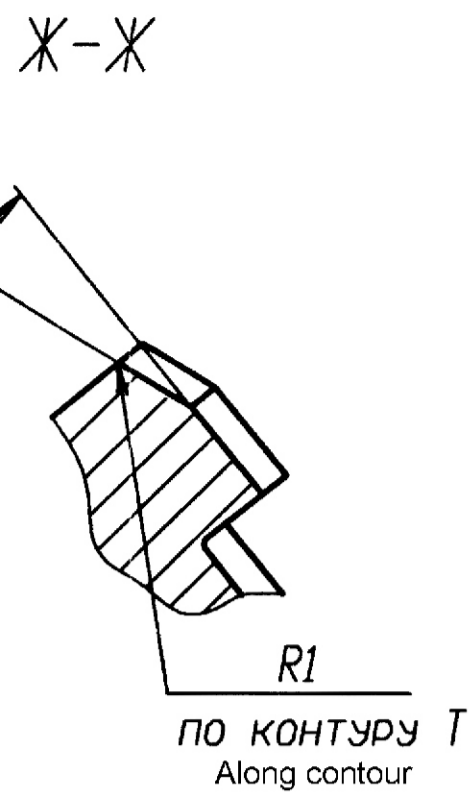
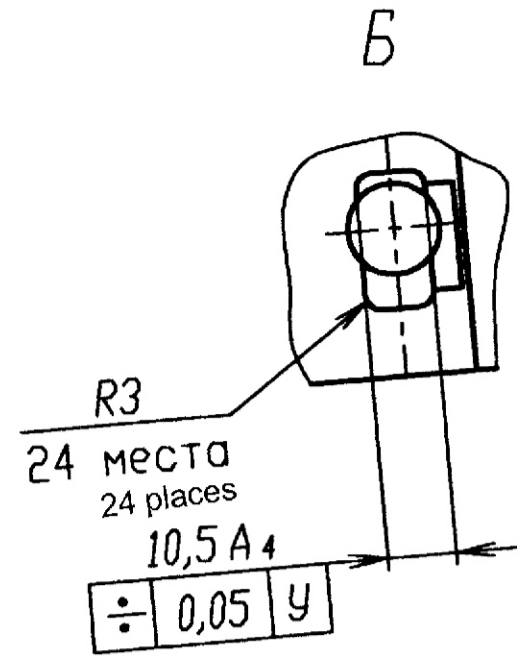
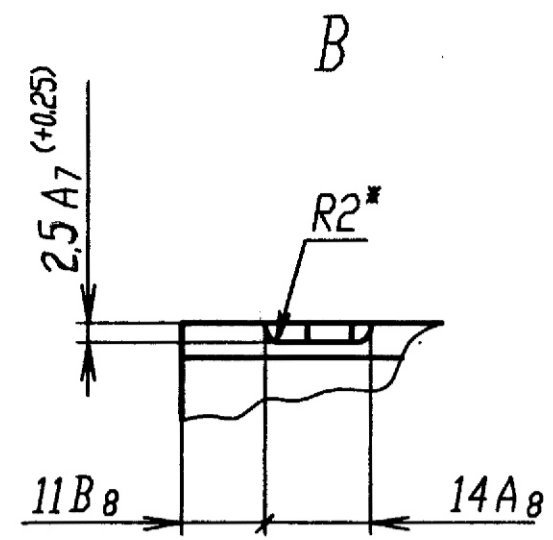

First remarks  
Reference No.  
Sign & Date  
Duplicate Inv. No.  
Sign & Date  
Alternate Inv. No.  
Sign & Date  
Inv. No.



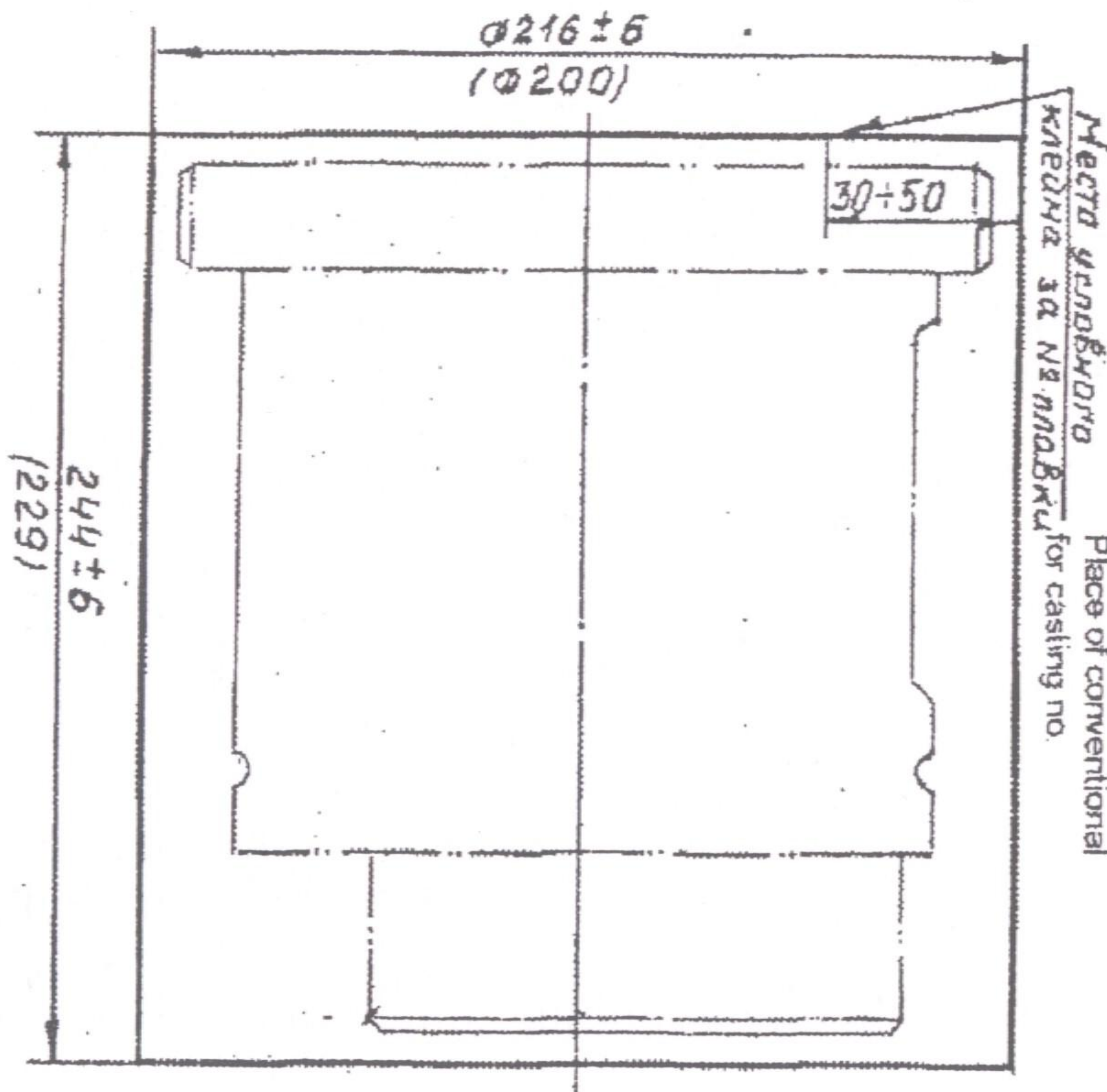

नियंत्रित  
CONTROLLED

- 1) MATERIAL-STEEL 30KhN2MFA-Sh OST3-98-80
- 2) HEAT TREATMENT-NORMALIZATION WITH HIGH TEMPERING  $d_{temp.} \geq 3.7$
- 3) CAVITIES,CUTS AND DENTS WITH DEPTH UP TO 0.8mm IS PERMISSIBLE.
- 4) BLANK-FORGING
- 5) DIMENSIONS IN BRACKETS-FOR MACHINING.
- 6) MARK WITH LETTER SIZE 5-G03 GOST 26008-85 WITH CONVENTIONAL STAMPS FOR CASTING NO.  
HEIGHT OF TERRAIN DIGIT 0.5...0.8mm

Authenticated by: *B.K. Chakraborty*  
(B.K. Chakraborty) *Prerna Sarkar*  
JWM/EDC

ITEM NO.	NO. OFF	MATERIAL	DESCRIPTION
LIST OF PARTS			
SCHEDULE NO :-		COMPT.:- BREECH RING	STORE DRG NO.
SCALE :-NTS		AK-630 M GUN	AO-18.01.001
PROJECTION THIRD ANGLE		<b>BREECH RING FORGING (P.Y.T)</b>	
DRAWN BY : <i>Chakraborty 9/3/07</i>		<b>DRG.NO. F-2260</b>	
TRACED BY :			
CHECKED BY : <i>Prerna 9/3/07</i>			
APPROVED BY : <i>Prerna 09.03.07</i>			
DT.&SG.	DESCRIPTION	CONCURRED BY:	M / C :
			NO. OF SHTS.:-1
AMENDMENTS	SIGN.	DATE :	G. & S. FY. COSSIPORE.
			SHT. NO. :-1