

DRAWING NUMBER
172.41.137

SHEET No. 1 OF 1

✓ (✓)

N
(5,5±1,0) H [(10,55±0,10) кгс]

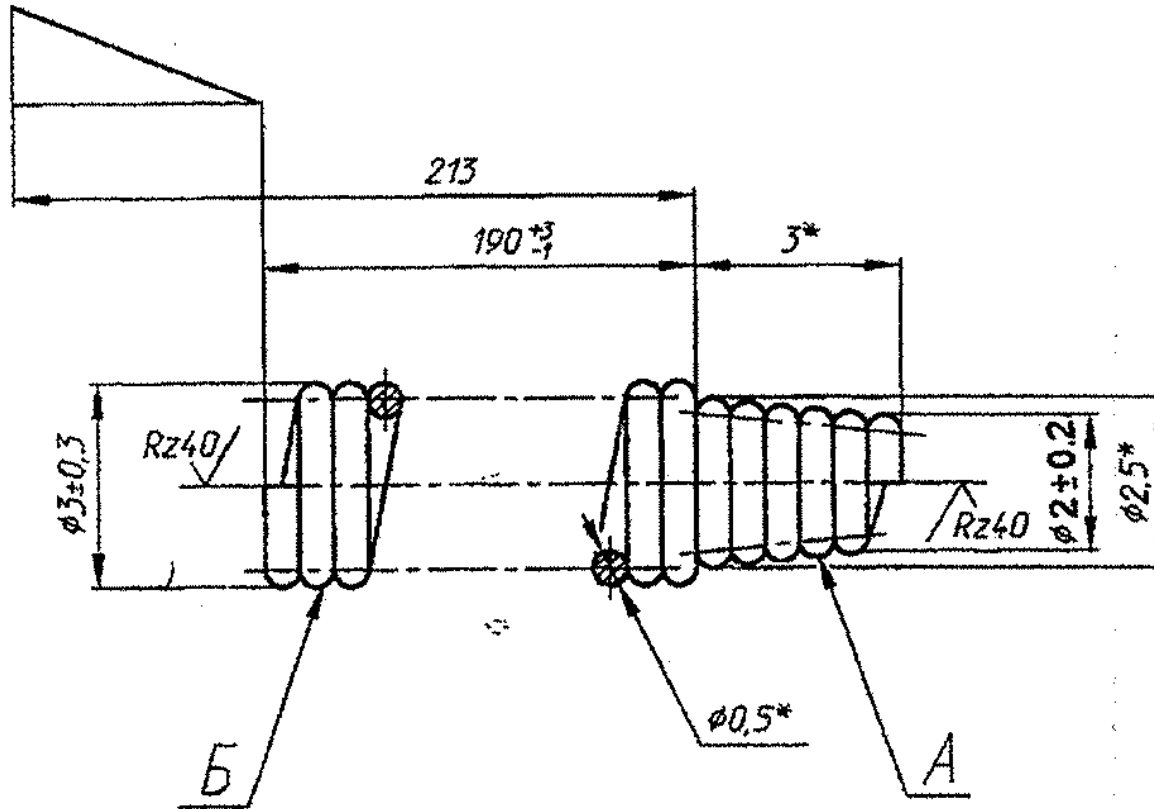

1. Coiling should be tight, gap between turns is not allowed.
2. Direction of winding is optional.
3. During three fold stretching upto 255 mm length, residual deformation is not allowed.
4. Spring should be twisted into the ring and the edge A should be screwed in to the edge B till tight joining.
Strength of lock should be checked by fitting to mandrel with 75 mm diameter.
5. Twisting of turned-in spring into the ring in the shape of eight is not allowed
Clearance in the plane of spring turned in to the ring is 0⁺³ mm.
6. Internal diameter of spring turned-in to the ring is 60^{+1,5} mm.
7. * Dimensions for reference.
8. Coating: Chemical oxidizing, oil finish
9. Remaining requirements as per 520.TY1.

MASTER COPY

ALT. MATL. IS: 445.4-PT. 1-GY.3

AUTHY. CQA (HV) letter no. 891/1PD/IND-V/MTPF/OE/JA 17⁰⁹

DRG. INDIANISED BASED ON RUSSIAN ORIGINAL ISSUE - 4

356

SUPPLY CODE
U-01-1-2

D90058

F-79
3a

SIZE A3

PILOT SAMPLE SHOULD BE APPROVED BY A H S P
BEFORE BULK PRODUCTION.

EST. WT. (Kg) TO BE STAMPED OR MARKED WHERE
0.0027 INDICATED THUS # (LETTERS)

ALL SHARP EDGES AND CORNERS TO BE REMOVED UNLESS
OTHERWISE STATED MACHINED CORNERS TO HAVE R OUT-
SIDE R INSIDE EQUIVALENT CHAMFERS ARE PERMISSIBLE.

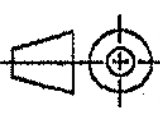
		DRN	V @	MATERIAL:- Wire 5-2A-0.5 GOST-9389-75	USED ON:- 175.41.008cb-1Cb
		CHD	S. Ganagan	CONTROLLERATE OF QUALITY ASSURANCE (HEAVY VEHICLES) AVADI	
		APPD	P. Ommy		
		DATE	31. 08. 04	TITLE:-  SPRING	
		SCALE:-	10 : 1		
		DIMENSIONS IN mm		D S CAT NUMBER	
		TOLERANCE ON DIMNS UNLESS OTHERWISE STATED IS: 2102-69			
		ALL THREADS TO CONFORM TO		DRAWING NUMBER 172.41.137	
8	7	6	ISSUE	DATE	NATURE OF AMENDMENTS