

6085-SK-5800

GEN. TOL. FINE/MEDIUM/COURSE  
 DRG. CONVENTION CONFIRM TO INDIAN STD.  
 DIMM. IN mm UNLESS OTHERWISE STATED.

(PROVISIONAL)

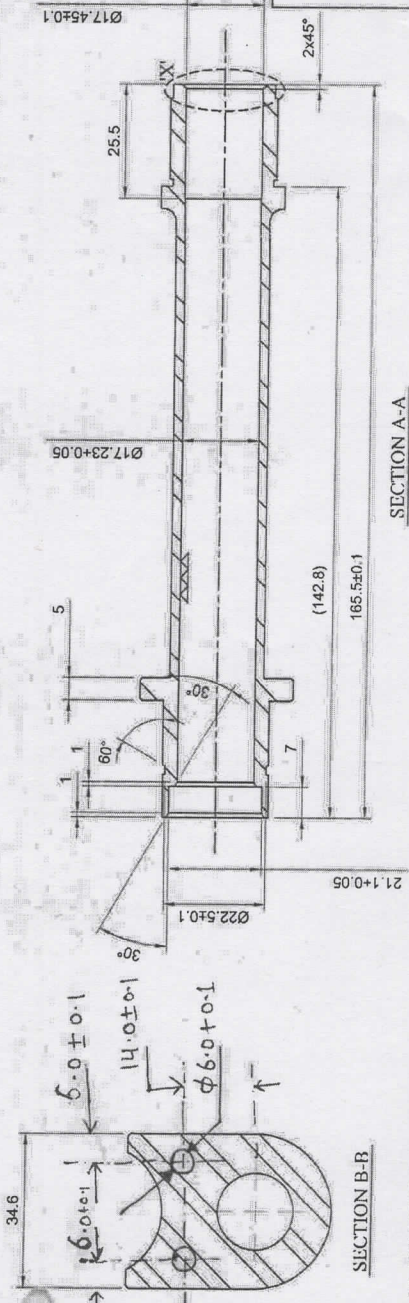
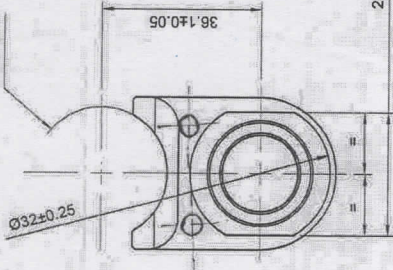
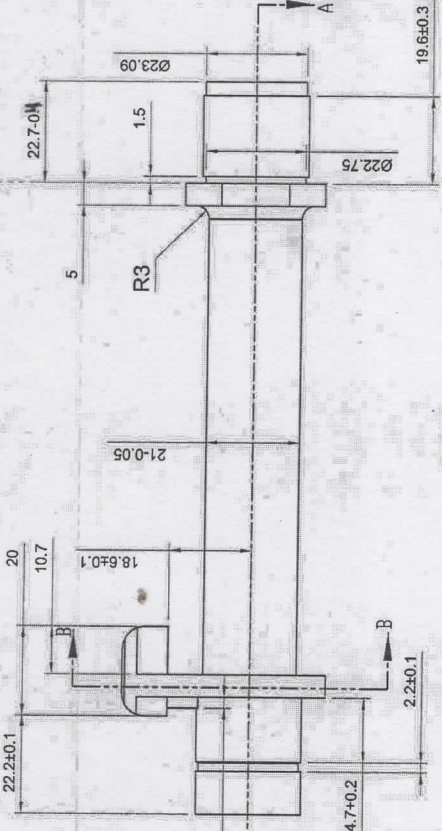
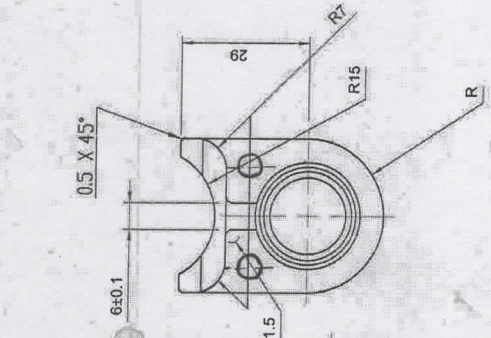
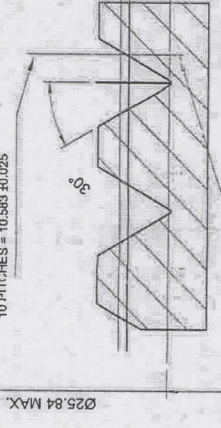
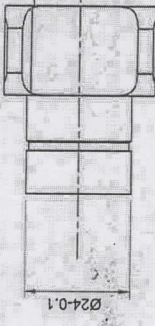
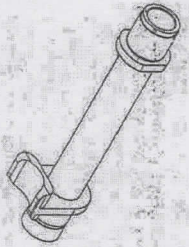

MATERIAL :- BS 970 PT. 1 : 1993 Gr. 060 A 62 OR 080 A 62 OR 060 A 67 OR 080 A 67 OR 817 M40 T- CONDITION

HEAT TREATMENT :-

NORMALIZED LOCAL INDUCTION HEATING AT 'X' OR QUENCHED AND TEMPERED AT 250-300°C

PROTECTIVE FINISH :- PHOSPHATE TO SPECN. JSS. 0465 :01-1994 CLASS-II (ACCELERATED), OIL FINISH.

Hos. M. P. ...  
 प्रतिलिपि विनॉक ...  
 Certified by ...  
 of drg. on ...  
 F. ...  
 Sr. Works Manager  
 श्रीकेश प्रसाद

DRAWN TRACED CHKD.		DATE 19-07-2018	
APPROVED		APPROVED	
DRG. NO. SK-5809		Ref. Drg. No.-ARDE/SK/10R/010	
SHEET NO. 1-1		SHEET NO. 1-1	
SCALE 1:1		SCALE 1:1	
SMALL ARMS FACTORY KANPUR		SMALL ARMS FACTORY KANPUR	
LMG 7.62X51mm BELT FED CYLINDER GAS		LMG 7.62X51mm BELT FED CYLINDER GAS	

ALL DIMENSIONS ARE IN mm.  
 IMPORTANT DIMMS ARE MARKED WITH ⊕ ( ±0.003)  
 INFORMATION MARKED WITH † TO BE MARKED ON SURFACE. MARKED 'G' TO BE GROUND