

DRAWING CONVENTIONS CONFORM TO IS: 696.

SURFACES FINISH:- AS PER IS: 9073-67.  
WHERE NOT SPECIFIED SHOULD BE V.

MATERIAL:-

A-PB-O-2 GOST 19904-74  
 SHEET 4-II-35 GOST 16523-70

ALTERNATIVE MATERIAL:- SHEET A-PB-O-2 GOST 19904-74  
 4-II-40 GOST 16523-70

MATERIAL FOR INDIA:- IS: 7228-1974 DESIGN. C40

~~IS: 1149-1974 SEC. 1, 49-66~~

HARDNESS:- 34-41 HRC., IT IS TO BE CHECKED ON TEST PIECE.  
DIMENSIONS FOR REFERENCE.

SHARP EDGES SHOULD BE BLUNTED TO 0.2 mm.

TOLERANCE ON CONTOUR 'EFG' IS 0.7mm.

ON SECTION 'G' DIML. 'B' IS PERMITTED TO BE CHANGED UP TO 6 ± 0.5 mm.

ON SECTION 'H' UNDER STAMPING UP TO DIMENSION 'K' IS ALLOWED.

ALL TOLERANCES ON LINEAR DIMENSIONS, WHICH DETERMINE

NOMINAL POSITION OF AXES ARE BASED ON MMC PRINCIPLE,

COATING:- ELECTROLES. ACCELERATED PHOSPHATING, OIL FINISHING

(COATING/ PROTECTIVE FINISH FOR INDIA:-

PHOSPHATE TO SPECN. JSS-0465-011986 CLASS II, OIL FINISH

STAMP 'K' (DIMENSIONAL ACCEPTANCE) AND 'W' (HARDNESS

CORRECTNESS) ON TAG.

REMAINING TECHNICAL REQUIREMENTS ARE, AS PER

IS: 1149 SPECIFICATIONS.

UN CONTROLLED COPY

CERTIFIED CORRECT COPY OF APPROVED

DRAWINGS AT THIS DATE

DESIGN & DRAWING OFFICE

ORDNANCE FACTORY, TIRUCHIRAPPALLI - 620 016.

A 2033

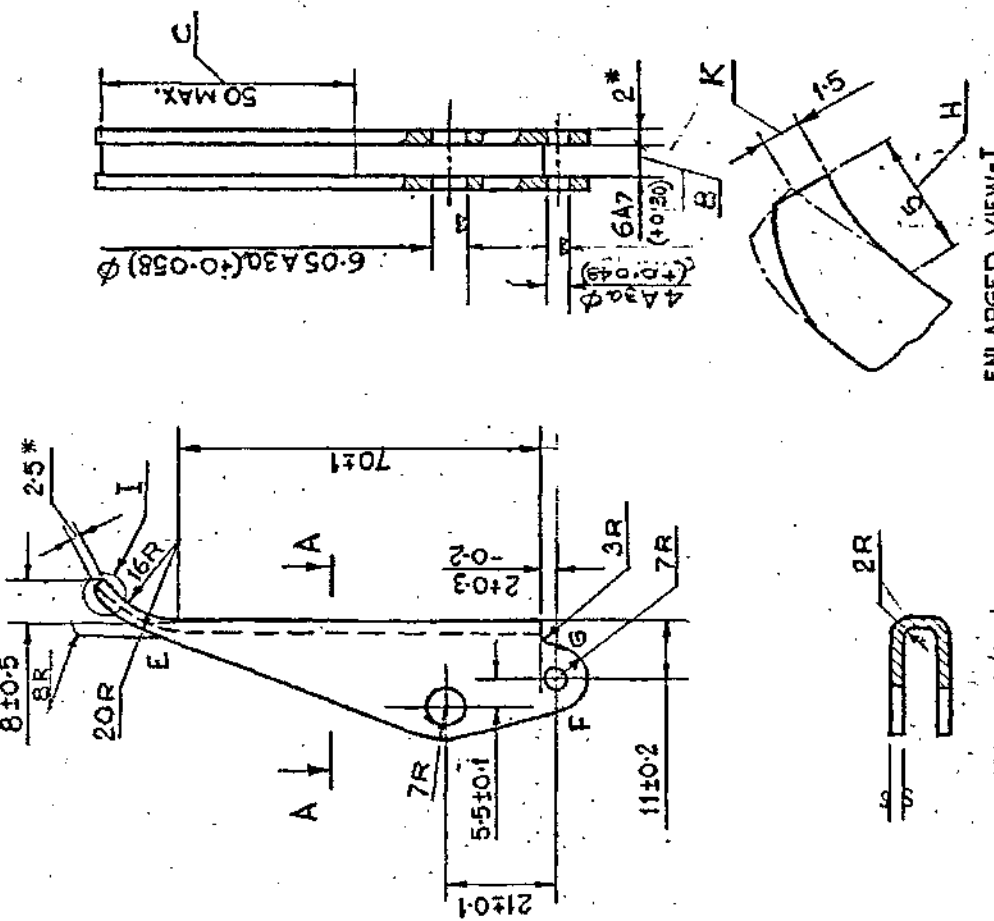

ENLARGED VIEW-I

SCALE: 5:1

SECTION-A-A

DATE	NAME	ASSY.	D.S. CAT NO.	COA(SA) CHAPUR
			1003-0073PA	
OGN.	DRN.	CHKD.	TRD.	COMR.
MATERIAL: AS STATED.				
DIMENSIONS ARE IN MILLIMETRES				
DT. 6.3.91 JC. D.O.				APPROVED: 3.1.86
SCALE: 1:1, 5:1				(NEG. PREPARED)
SEAL D: 20093-SA & 20747-SA				DESIGNER'S REF. 5/11 2-33
PROV. D (U) NO. 18766-44				D.S. CAT NO. 1005-007279
DT. 4.2.88				
HANDLE LOCK BARREL				

27094-SA 02.06.17	Material Amended 1.11.17				
27/65-26-3-91	DATE REVISED, RE-DRAWN AND				
SA	PROV. RE-SEALED				
	PREVIOUS DC(U) NO. 18766-44				
	20093-SA & 20747-SA				
AUTHY.	DATE	ZONE	SIG.		