

1 2 3 4 5 6 7 8

A

B

C

D

E

F

A

B

C

D

E

F

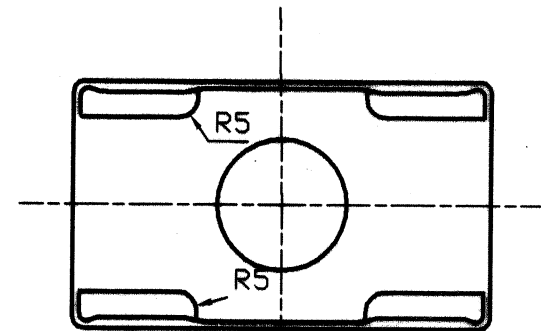
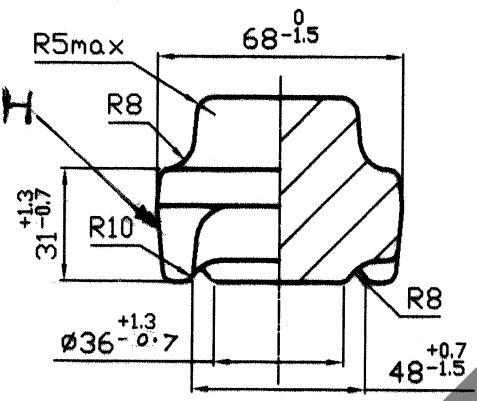
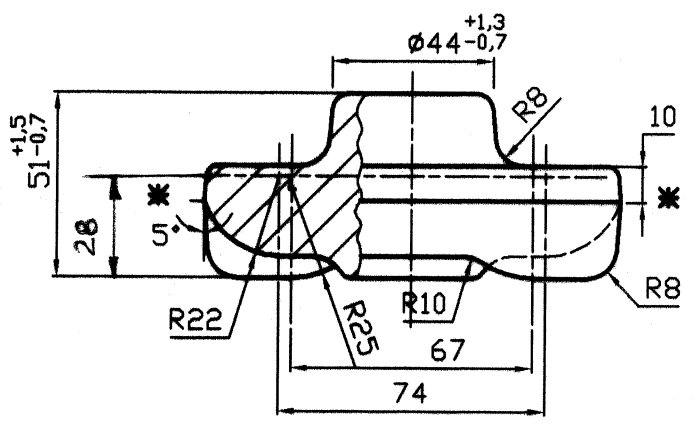
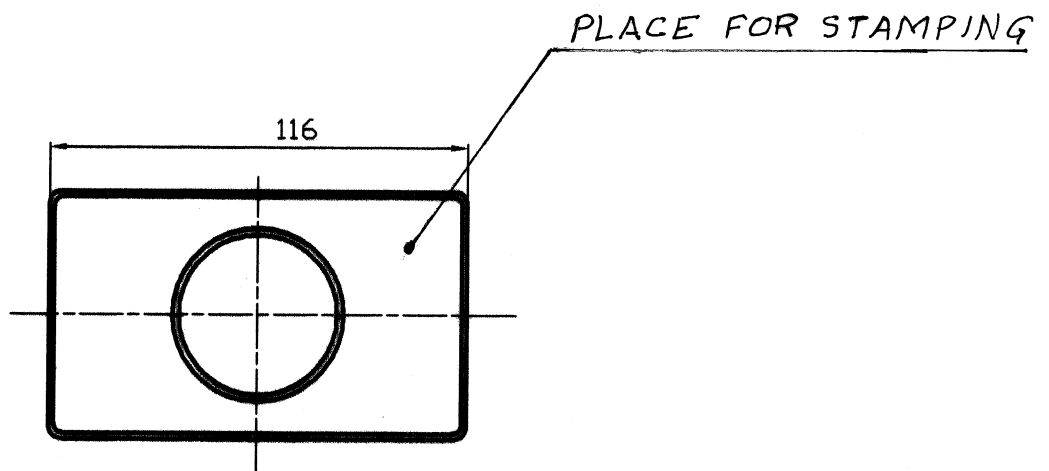

TECHNICAL REQUIREMENTS:

01. GROUP II, GOST 8479-70
02. PARAMETERS OF FORGING: T5, M2, C2, 14 GOST 7505-89.
03. HARDNESS 179...269 BHN (DIA. OF INDN. 3.7 TO 4.5MM)
04. UNSPECIFIED DRAFT 7°.
05. UNSPECIFIED RADIUS-3.0MM.
06. TOLERANCE OF SHIFT ALONG THE SURFACE OF PARTING LINE OF DIE IS 0.6 MM.
07. PERMISSIBLE LIMIT VALUE OF RESIDUAL FIN -0.9 MM.
08. PERMISSIBLE LIMIT HEIGHT OF BURR ALONG CONTOUR OF CUTTING -3.0MM
09. TOLERANCE OF FLATNESS AND CURVATURE 0.8MM.
10. DIMENSION WITHOUT TOLERANCE NEED NOT BE CHECKED.
11. FOLLOWING LOCAL DEFECTS ARE ALLOWED WITHOUT RECTIFICATION: DENTS, NICKS, SCALE AND TOOL MARKS IN AN AREA NOT MORE THAN 30% OF THE SURFACE AND DEPTH NOT MORE THAN 1MM. WRINKLES, GRIPS, LAPS AND ROLLING DEFECTS OF INPUT MATERIAL WITH DEPTH NOT MORE THAN 1MM ANYWHERE IN THE AREA NOT LESS THAN 15 MM FROM THE FACES. TOTAL NUMBER OF ALL SURFACE DEFECTS WITHOUT DRESSING SHOULD NOT BE MORE THAN TWO PER COMPONENT. SLIGHT DRESSING OF DEFECT WITHIN THE TOLERANCE LIMIT OF CORRESPONDING DIMENSION IS ALLOWED.
12. TO BE DE-SCALE (SHOT BLASTED) ON MACHINED SURFACEES TRACES OF SCALES NOT REMOVABLE BY DRESSING ARE ALLOWED.
13. ACCEPTANCE STAMPS ON ALL COMPONENTS.
14. EVERY BATCH QTY, 2 COMPONENTS TO BE LABELED WITH MARKING OF DRG. NO. AND BATCH NUMBER DEATILS.
15. PAINT RED OXIDE.

MATERIAL: STEEL 38XC GOST:4543-71
 CHEMICAL COMPOSITION IN % :-
 C-.34 TO .42, Si-1 TO 1.40, Mn-.3 TO .6, Cr- 1.30 TO 1.60 , S-0.035 , P-0.035

FORGING WT. 1.9 KGS

16. PLACE FOR HARDNESS TEST SURFACE 'H', HARDNESS TO BE CHECKED ON SAMPLE AFTER HEAT-TREATMENT.

Note:-These Drawings are only for reference. Actual drawings may be different and shall be issued at the time of procurement.

No part of these drawings may be reproduced in any form without prior permission in writing of OFM.

JT. G.M./ETQ

AWM/DO

1	1	#	SHOE
I.NO.	NO.OF	MATL.	DESCRIPTION
LIST OF PARTS			
		COMPT. SHOE	STORE DRG. NO 219-35-126/F
		DATE :- 20-4-05	FORGING DRG. FOR TA. SHOE
		SCALE : 1:2	DRG.NO. OFM 32848
DT.	SIG	DESCRIPTION	DRAWN PKRAD
AMENDMENTS		TRCD.	M/C
		CHKD.	O.F.MURADNAGAR
			NO.OF SHTS:- 1
			SHT. NO:- 1

1 2 3 4 5 6 7 8