

**MATERIAL :-** STEEL WIRE TO SPECN IS:1570-1961 DESIGNATION C20  
**WORKMAN SHIP :-** TO BE SOUNDLY WELDED AND EXTRA MATERIAL AT WELD SHALL BE REMOVED AND FINISHED SMOOTH.  
**FINISH :-** CADMIUM PLATED TO A MINIMUM THICKNESS OF 0.013mm AND CHROMATE PASSIVATED TO SPECIFICATION IS:1572 GRADE A, TYPEZ.  
**PROOF LOAD :-** 490 N (50kg)  
**PACKING :-** ONLY ONE TYPE OF TOWING RINGS SHALL BE PACKED IN ONE CARTON/C.W.P. EACH TOWING RING SHALL BE WRAPPED IN TISSUE PAPER AND 50 Nos. AND 100 Nos. OF LARGE AND SMALL RESPECTIVELY PACKED IN SUITABLE CARTONS. 10nos OF SUCH CARTONS SHALL BE PACKED IN A C.W.P. (DULY LINED WITH PAPER PACKING WATER PROOF). ONE TOWING RING IN EACH CARTON SHALL BE IDENTIFIED BY A LABEL SHOWING CAT No. DESIGNATION : OF THE STORE AND ALSO THE RECOGNISED INITIALS OF THE MANUFACTURER'S. EACH CARTON SHALL BE MARKED WITH THE INITIALS OF THE MANUFACTURER.  
**MFG. PROCESS :-** THE PACKING CASE SHALL BE INDELIBLY MARKED WITH THE ADDRESSES OF THE CONSIGNEE, CONSIGNOR, CAT No., DESIGNATION, YEAR OF THE MANUFACTURE, QUANTITY AND THE NUMBER OF THE INDIVIDUAL PACKS.  
 GENERAL ENGINEERING METHOD

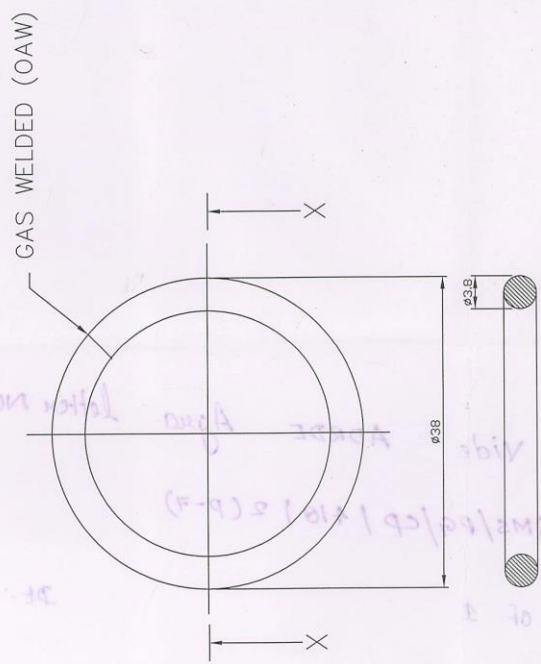

SCALE :- 2 : 1	ADDRDE, AGRA	DRN.	PRD. DFF.
DIMENSION IN mm	GROUP :- CP(H.I.D.SYSTEM)	CHD.	PM.
TOLERANCE:- IS/2002-1993	RING	DI/CDS	DI/CDS
MATERIAL:- AS ABOVE	MAT-91	APPROVED	APPROVED
FINISH- AS ABOVE	HEAVY DROP P/CHUTE (P-7 PLATFORM)	HEAD(DA)	HEAD(DA)
HEAT TREATMENT:-	SYSTEM IL-76 A/C	DRG.No. :-	1.6.01.04-09-01

REF. No.	DATE	ZONE	AUTHORITY	1
				2
				3
				4

BRIEF RECORD