

DRAWING NUMBER  
520.01.003

SHEET No. 1 OF 1

Rz80/√

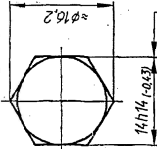
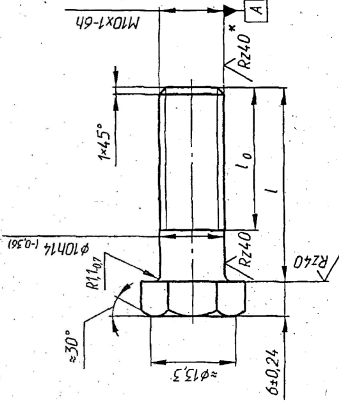

7/2, 0.45 A

ALTERNATE DESIGN OF BOLT

ВАРИАНТ  
ALTERNATE

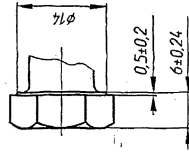

ВАРИАНТ  
ИСПОЛНЕННАЯ ДИЛНА (>35MM)

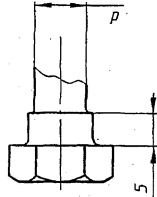

1. Alternate material: Steel 40 GOST 1050-88 and Steel 20nc GOST 10702-78.
2. Diameter d should be within the pitch diameter of thread.
3. Bolt head may be made as per GOST 7796-70.
4. When making thread by the method of rolling, unthreaded part of rod may be made along the pitch diameter of thread and chamfer at the end of rod is not to be made.
5. Coating Zn 6 Chromotizing.
6. \* Surface finish is to be ensured by tool.
7. Other requirements should be as per GOST 1759.0-87 and 520.TY1.

| ОБОЗНАЧЕНИЕ<br>PART NO | LIMIT DEVIATION      |                      | WEIGHT<br>MCCO.<br>KG |
|------------------------|----------------------|----------------------|-----------------------|
|                        | ИЗМЕР.<br>ДИМ.<br>MM | ИЗМЕР.<br>ДИМ.<br>MM |                       |
| 520.01.003             | 18                   | 16                   | 0.0161                |
|                        | 20                   | 20                   | 0.0192                |
|                        | 22                   | 22                   | 0.0204                |
|                        | 25                   | 25                   | 0.0221                |
|                        | 30                   | 30                   | 0.0249                |
|                        | 35                   | 35                   | 0.0281                |
|                        | 40                   | 40                   | 0.0312                |
|                        | 45                   | 45                   | 0.0343                |
|                        | 50                   | 50                   | 0.0374                |
|                        | 55                   | 55                   | 0.0405                |
|                        | 60                   | 60                   | 0.0435                |
|                        | 70                   | 70                   | 0.0497                |

PILOT SAMPLE SHOULD BE APPROVED BY A H S P BEFORE BULK PRODUCTION.

EST. WT. (KG) TO BE STAMPED OR MARKED WHERE INDICATED THIS # ( LETTERS)

SEE TABLE ALL SHARP EDGES AND CORNERS TO BE REMOVED UNLESS OTHERWISE STATED MACHINED CORNERS TO HAVE R OUT-SIDE R INSIDE EQUIVALENT CHAMFERS ARE PERMISSIBLE.

|   |                  |   |           |
|---|------------------|---|-----------|
| DRN   | СРЕДСТВ. КОМП. № | MATERIAL:-  | USED ON:- |
| CHD   | №                | STEEL 20 GOST 1050-88                               |           |
| APPD  | №                | CONTROL PLANT OF QUALITY ASSURANCE (HEAVY VEHICLES) |           |
| DATE  | 17-02-04         | AYADI   |           |
| SCALE   |                  |   |           |
| DIMENSIONS IN mm                                      |                  | TITLE:-   |           |
| TOLERANCE ON DIMS UNLESS OTHERWISE STATED IS: 2102-69 |                  | BOLT  |           |
| ALL THREADS TO CONFORM TO                             |                  | D'S CAT NUMBER                                      |           |
| ISSUE   |                  | DRAWING NUMBER                                      |           |
| DATE  |                  | 520.01.003  |           |
| NATURE OF AMENDMENTS                                  |                  |   |           |

356

SUPPLY CODE  
U-01-1-1  
D90033



SIZE A4\*3

COMMON TO 1-72

DRG. INDIANISED BASED ON RUSSIAN ORIGINAL ISSUE - 6