

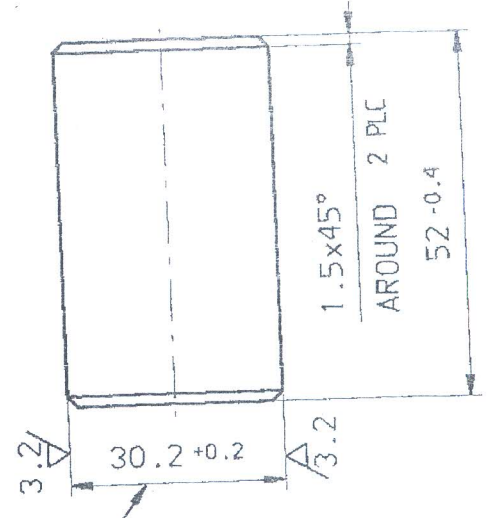

NOTES:

1. CHAMFERED 0.2x45°

NO. 17/1983 (Part 1) of 1983
 2005. THE GOVERNMENT OF INDIA
 ALL THE RIGHTS RESERVED BY
 IN PART SHALL NOT BE MADE
 WITHOUT THE WRITTEN PERMISSION
 OF OFB

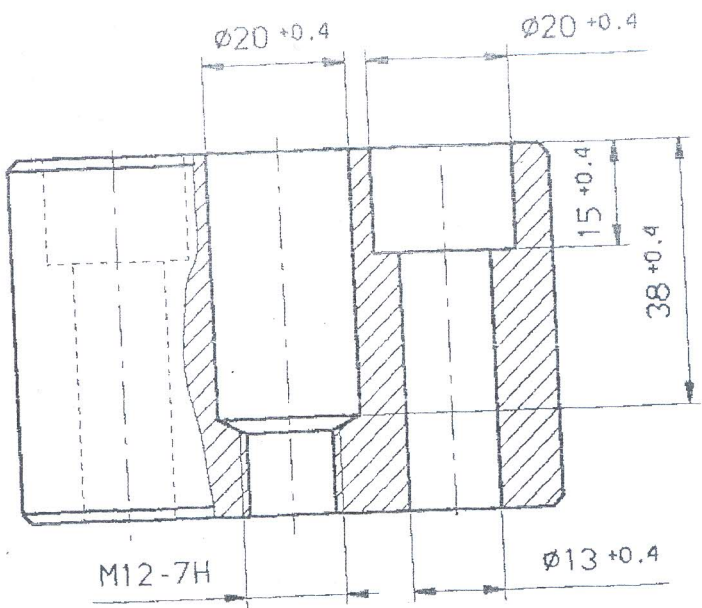

Final dimension to be fitted at assembly with barrel and breech block

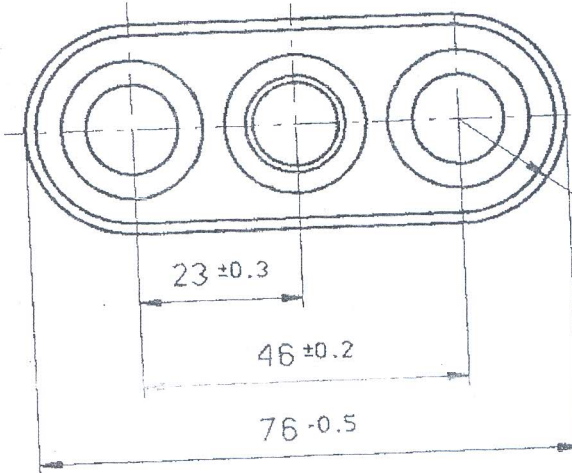

FULL_R
2 PLC

केवल निर्धारित हेतु
 संख्या यौग पत्र नं. 380286
 दिनांक 04-05-2018

DATE: 01.01.2007	ALTERNATE/ INDIGENOUS MATERIAL SPCN: BS:970: Pt-1:1983 GDE 150 M90 Heat treated to 'P' Condition. (REF: CQA(W) JABALPUR LNo. 3B2402/CQAW/011 Dt. 12 JULY 2005)	143 JWM/CDD
---------------------	--	----------------

6.3/ (3.2/)
MACHINING INSTRUCTIONS

ID. No. 1969
 Location 01/04/01

18912-W
 Dt. 27-5-2005
 DRAWING SEALED
 CQA (W), JABALPUR

UNSPECIFIED TOLERANCES FOR DIMENSIONS AND ANGLES DIMENSIONS

PART NO. SHARANG 130/155MM_UG_OFB_SLB

UPDATED
 Shr: 1
 of: 1

PREP'D	CHK'D
GHO	Shr
JWM/DO	Shr
APPROVED	
DO/DO	DIR/ODG

ANGLES

HEAT TREATMENT

SCALE 1:1
 SIZE A4

ORDNANCE DEVELOPMENT CENTRE, OFC, KANPUR

FINISH

ASSEMBLY 176-1002

PART NO. 176-1104

MATERIAL L=58
 FLAT 80x35 DIN 9017-S1 52-3

NAME KEY