

THE DRAWING/DOCUMENT CONTAINS
 COMPANY PROPRIETARY INFORMATION
 USE OF THIS DOCUMENT IN WHOLE OR
 IN PART SHALL NOT BE MADE
 WITHOUT THE WRITTEN PERMISSION
 OF OFB

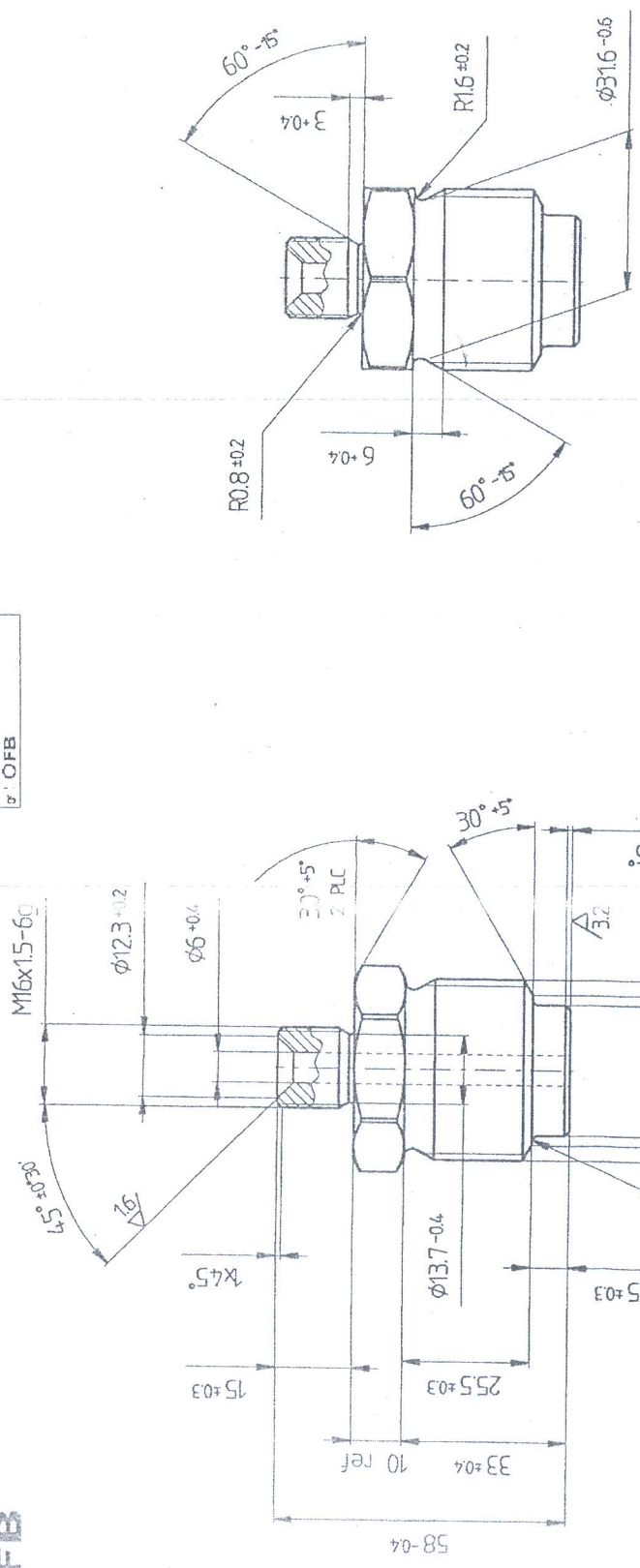
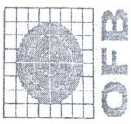

केवल निविदा हेतु
 सप्तम मंथन पर 380259
 दिनांक 03-05-2018

DATE: 01.01.2007
 ALTERNATE/INDIGENOUS MATERIAL SPEC: BS 970 Pt-183 Gd 709 M40 heat treated to condition. A separate test bar shall be heat treated to achieve the hardness 30-35 HRC. (REF: COA(W) JABALPUR L.No. 332-02/COA(W)/11 Dt. 12 JULY 2005)

6.3	(3.2, 1.6)	MAKING INSTRUCTIONS	UNSPECIFIED TOLERANCES FOR DIMENSIONS AND ANGLES	HEAT TREATMENT	30-35 HRC	FINISH	PHOSPHATE COATING ACCORDING TO DD-P-822 TYPE H CL. 2	MATERIAL	Round 42 DIN 1013-42CrMo4
ID.No. 1946		DRAWING SEALED		SHARANG 130/155MM_UG_OFB_SIB		ASSEMBLY		ADAPTER	
Dt. 27-5-2006		CQA (W), JABALPUR		SR: 1		SCALE		PART NO.	
Dt. 12 JULY 2005		CQA (W), JABALPUR		DF: 1		1:1 A3		NAME	
JUN/ICDD		DEVELOPMENT CENTRE, OFC, KANPUR		L=70		176-1002		161-1500	

