

Ritningsändring - G H J K  
 Produktförändring F - - - -

(D)

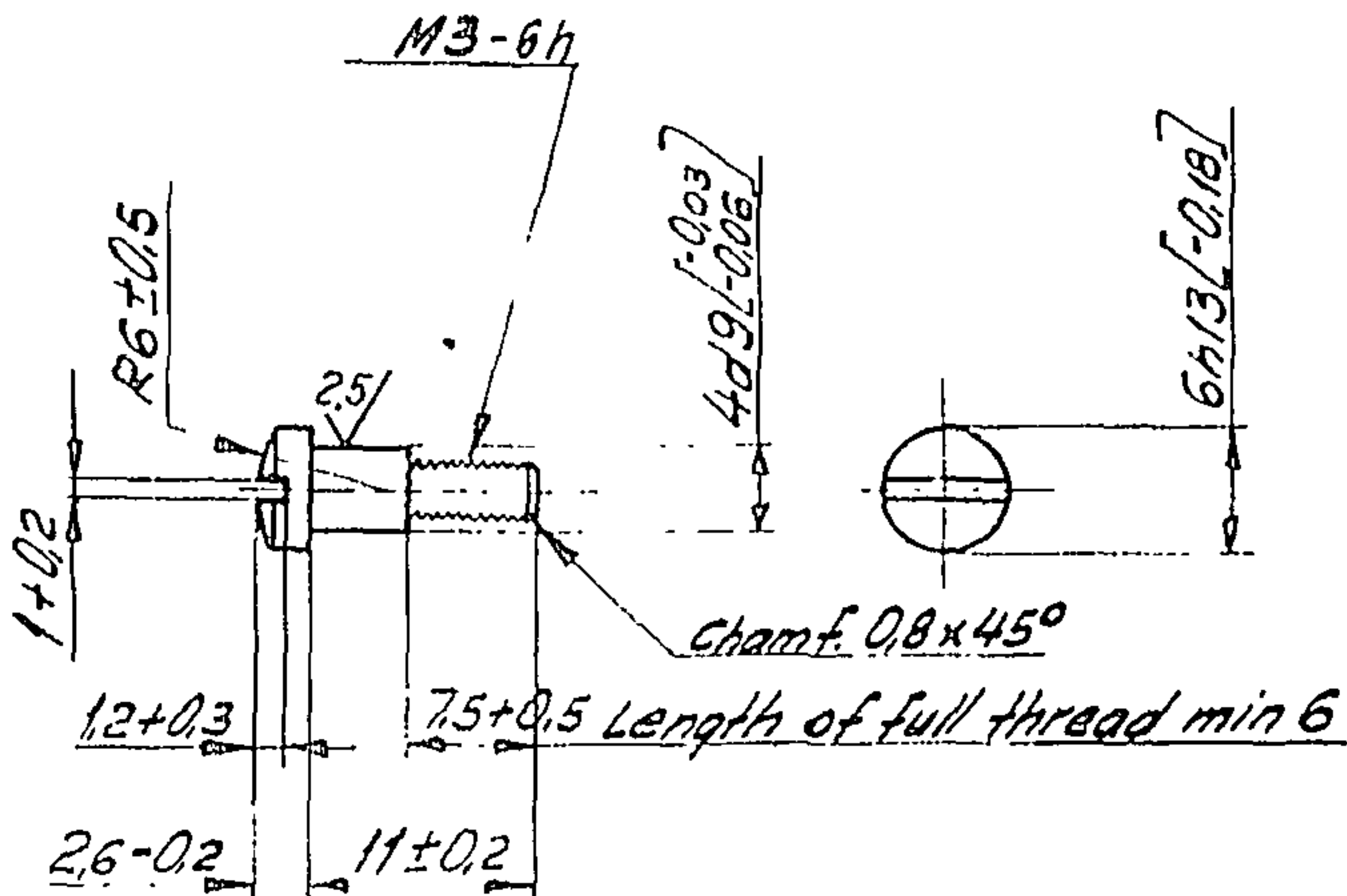

Scale 1:1

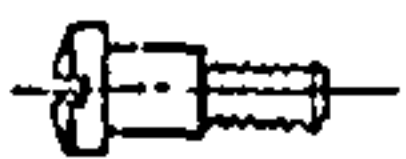

D.C.:- 2423-I(P):2729-ICP, 2750-ICP

ANTAL PRODUKT. (ca)  
 MATERIALKVALITÉT IS: 4431-78 STEEL DESIGN 11C10S25  
 VARMEBEHANDLING Hardened - surface hardness min 700 HV1 Hardness depth DC max 0,2  
 YTBEKÄFFENHET. 6.3/ unless otherwise stated  
 YTBEHANDLING: Manganese phosphated and oiled to Gf. 1.003.064  
 GRADNING: ENL. FFV 66  
 LAGESMÅTT: ENL. FFV 213  
 MARKNING: ---  
 TEKN. BESTÄMMELSER: See above

(A) D.C.:- 2750-2(P) - DRG. NO. AMENDED.	✓	6.12.11
(A) D.C. 2729-ICP. SPEC. & MATL. AMENDED.	✓	7.3.11
D.C.:- 2423-I(P) DRG. PROV. SEALED	✓	18.7.07
AMENDMENTS	CHD	SIG DATE

Ritad 8H9 Gransk Kop. OL Gostk 6/8 Kontur Vyplaceringssymbol europenk Skala 2:1  
 Datum 11-2-48 Stund nr Kup. nr 21 Utform Ersätter

PRODUKT Acc.f. 84mm RCLM2 Telescopic Sight 230141  
 NAMN Screw, long, housing

FORSVARETS FABRIKSVERK  
 CARL GUSTAFS STADS GEVÄRSFAKTORI CQA(1)-792/31 (a)

DRG. VETTED BY AMI - AS