

315-620-7

00538

Regulator cover

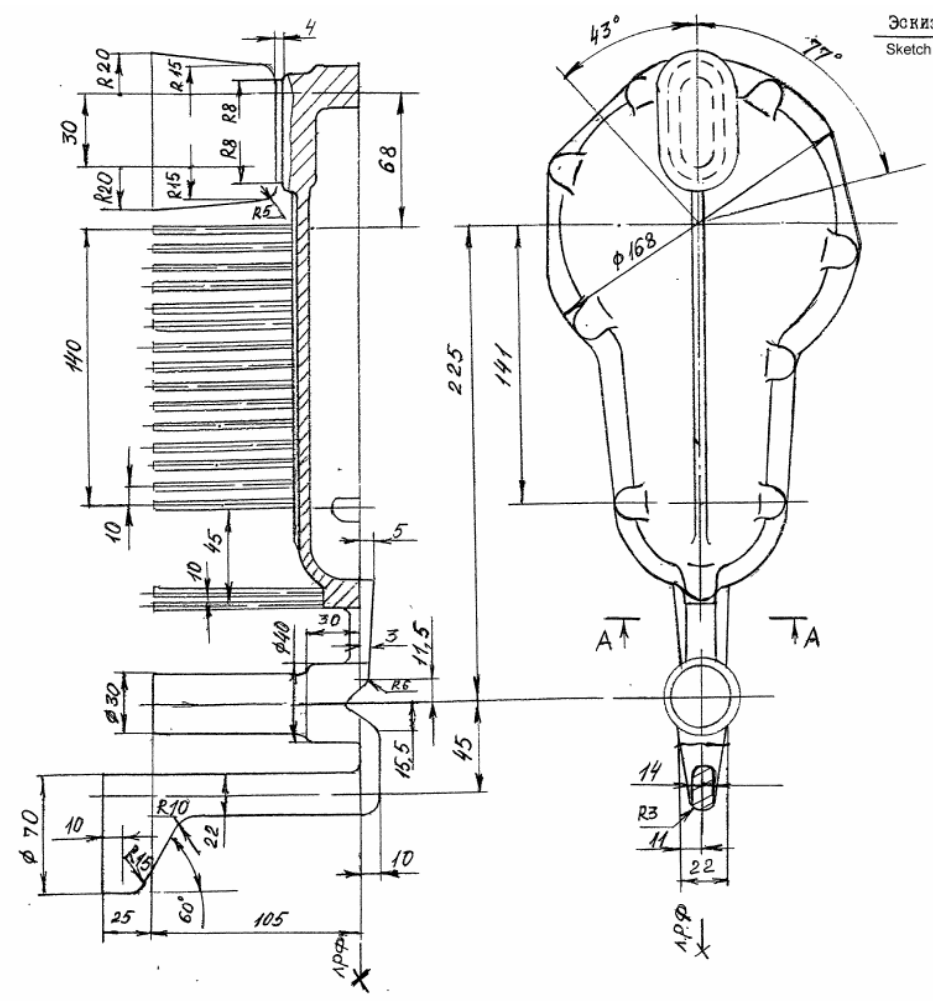

Эскиз втулки  
Sketch of bush

1. Alluminium casting in casting mold.
2. Unspecified slope of runner gate system is 3°, unspecified radii is not more than 5 mm.
3. During designing of cast mold tooling to consider the shrinkage 1%,