

17608-W REF OF SPEC IS: 4454
15-5-93 AMENDED.
17119-W 2ND ALT MATL ADDED,
6-9-91

Spec. nr Spec. No.	Gruppenämning Group denomination	Toleranser enligt ISO Tolerances acc. to ISO	
1140178	Avfyringshus	Basmått och tolerans Basic size and tolerance	Gränsmått Limit deviation övre, upper undre, lower
	17077-W 11-6-91 ALT MAT ADDED.		

ID = 786
01-01-02

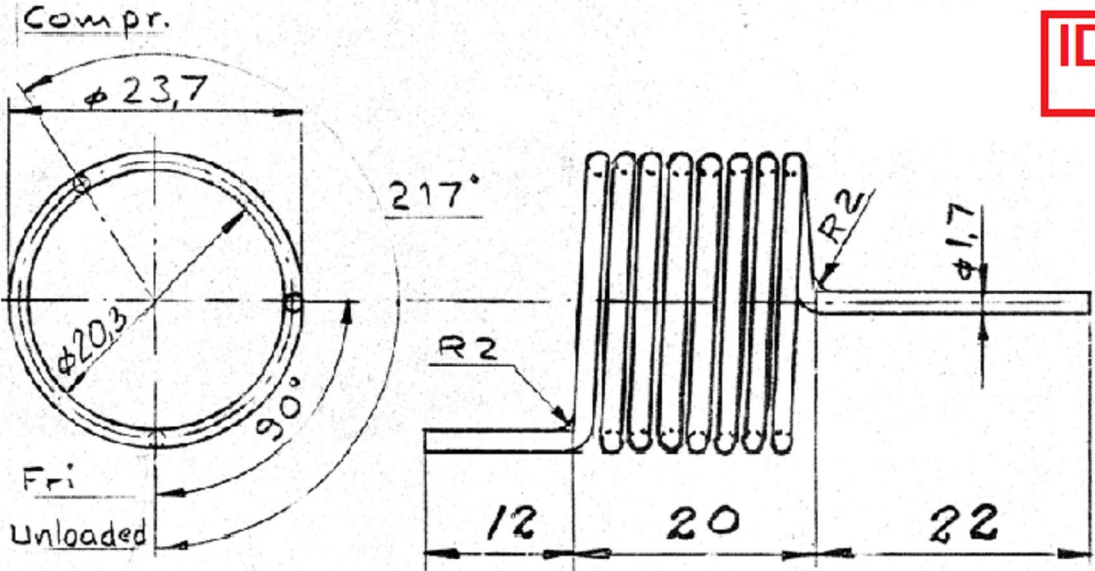

Compr.
Unloaded

Antal varv $7 \frac{3}{4}$
 $P_k = 5 \text{ kp}$ vid 217° kompr
 Number of turns $7 \frac{3}{4}$
 Full load = 5 kp at 217° compressed

ALT. MATL.: IS: 4454, Pt.2, 1981 Grade 2
 ALT. MATL.: BS: 5216-1975, Code HD Gr 3

19321-W ALT. MATL.: IS: 4454, Pt.2, 1981 Grade 2 DELETED
 01.04.2013 Auth. : IAF/DGQA-19, No. CQAW/P1/15/13, Dt. 20 Mar 2013

	16543-W 18-5-87 DRG. SEALED PROV.			
1	7 3/4 varv var 8 ÅO 39 030 210	83-10-12	ES	
-	Engelsk text tillägg	8-12-09		
Ändr. nr Rev. No.	Läge Zone	ÄO nr och ändringsbeskrivning Revision order No. and description of the revision	Datum Date	Godkänd Approved

Där ej annat angetts gäller Unless otherwise stated the following apply:		Ritad Drawn Eke	Beteckning Designation S151774-04	
Mått före ytbehandling Dimension before surface treatment	Skarpa kanter brutna Sharp edges broken	Kontr. Checked HQS	Material	Tillstånd
Ytjämnhet R_a μm Surface roughness R_a μm	Hålkäteradier Fillet radii	Ävd. Dept. KXR	Condition	
Toleranser för klippning och gaskärmning enligt T2-3 Tolerances for clipping and flame-cutting acc. to T2-3	Bearbetningstoleranser enl. T2-2 klass: Machining tolerances acc. to T2-2 class:	Datum Date 19.05.30	Utgångsvara Basic material	
	Svetsstoleranser enl. T2-4 klass: Welding tolerances acc. to T2-4 class:	Skala Scale 2:1	Föregående ritning Previous drawing	Vikt Weight k 0,005
Ytbehandlad Surface treated Y051		Vyplacering Proj. method	BOFORS	
Benämning Fjäder		Ritning nr Drawing No.		
Denomination Spring		6 349 433	Senaste ändr. Latest rev.	

Status and must not be disclosed to any third party, copied, reproduced or used in any manner whatever without the written consent of Aktiebolaget Bofors. Contravention will be prosecuted.